



Pro-10R_{ALK}

115mJ S3

ELECTRICAL WIRING & OPERATING INSTRUCTIONS

Applicable
S/No's 44xxxx

**FAILURE TO FOLLOW INSTRUCTIONS
WILL VOID WARRANTY**

CONTENTS:

2. Installation notes
7. Connections and specifications
8. Reluctor triggered ignition
9. Rev limiter
10. Mounting dimensions

INSTALLATION NOTES

(Pro-Street Series 3 systems)

MOUNTING

Mount the unit in a dry location away from intense heat and ensure bottom condensation slots are unobstructed and oriented to permit gravity drain.

Failure to use supplied rubber mounts will void warranty!

IGNITION LEADS

Use inductively suppressed spiral wound metal conductor ignition leads.

Do not use carbon core or unsuppressed metal leads!

SPARK PLUGS

Non resistor spark plugs will greatly enhance ignition performance however some installations will require the use of resistor spark plugs for correct ECU operation.

When using resistor spark plugs it is imperative to check internal resistance as part of regular maintenance!

Open circuit or high resistance may cause damage to spark plug wires, ignition coils and CDI.

Fixed gap surface discharge and semi surface discharge spark plugs are only suitable for naturally aspirated applications.

Keep spark plug gap ≤ 0.025 " (0.6mm) for boosted motors to prevent coil and CDI damage!

INSULATION PRECAUTIONS

Degrease sparkplug insulators, sparkplug boots, ignition coil boots and installation tooling to prevent insulation breakdown.

Use of dielectric grease on sparkplug insulators and inside sparkplug and ignition coil boots will aid installation/removal and help prevent high voltage flashover.

POWER SUPPLY

Do not use voltage boosters, if the vehicle contains a PDM use it only to control CDI switch wire.

Connect ignition supply wires directly to battery!

When using a total loss electrical system install either a 16V or 18V battery to ensure adequate voltage and isolate when charging.

WIRING

If required power/ground wire length exceeds recommendations use paired battery cable (power and ground) to make up distance. Do not rely on vehicle chassis to provide ground path.

Use twisted pair wire for all power and coil connections. For improved noise suppression or to comply with EMC requirements use twisted shielded wire similar to M27500 series.

M&W CDI systems will open circuit the external fuse if over voltage conditions are experienced. Faults such as loose battery terminals/wiring or defective alternator/regulator may also cause this to occur.

Main connector pins are designed for roll crimping. Squeeze crimping or soldering will distort pins resulting in misfiring or incorrect CDI operation. Use of dielectric grease in main connector may reduce water ingress.

Keep coil primary wires well separated from HT leads, coil HV outlet, coil body and any ECU wiring!

TRIGGERING

M&W Reluctor trigger CDI systems fire on the negative going zero crossing point of the signal to provide the most stable timing point.

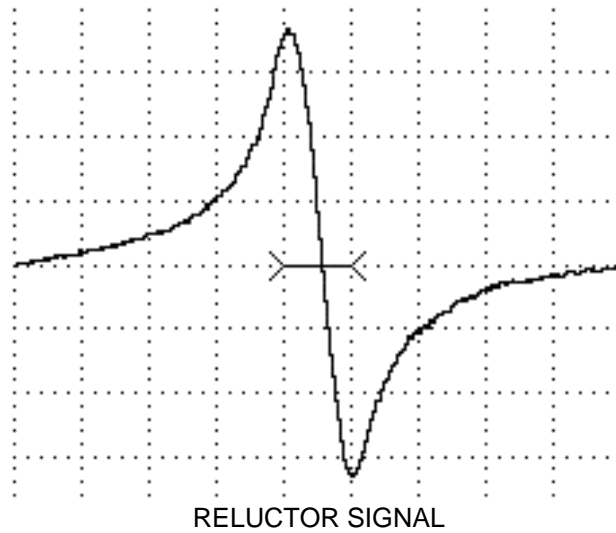

Older ignition systems may trigger off a different waveform location and require the reductor signal be reversed. When observed with a timing light correct polarity will show the most advanced and stable timing.

Use twisted shielded cable for reductor wiring and do not route near high voltage or high current conductors!

POWER LEVEL SWITCH

Do not manually activate this feature or operate continuously as this will significantly increase spark plug wear and system current draw.

Activate by grounding input via a 'Hobbs' style manifold pressure switch when elevated energy levels are required.

Use Hi power mode with caution, the increased electrical noise may interfere with reductor signal!

TUNING

M&W CDI systems may reduce ignition delay requiring a reduction in timing. The resulting changes in combustion characteristics may also require alterations to fuel flow.

Always re-tune both fuel and timing curves after installation!

TACHO OUTPUT

Tacho output provides a 50% duty cycle square wave signal approximately 1V below supply voltage. This will work with most aftermarket digital tacho's however some earlier types and those

designed for coil negative triggering may not read accurately and require an adaptor.

LED INDICATOR

After applying power to input switch wire the LED will illuminate for approximately 1 second then extinguish. It will then flash briefly with each consecutive trigger event received.

A repeated double flash of the LED may indicate a possible faulty ignition coil, faulty wiring, low supply voltage or damage to the CDI.

TESTING

Reluctor CDI's may not trigger by grounding inputs, in this case you will need to provide an AC signal such as that generated by a reluctor distributor.

Do not conduct this test without grounded spark plugs installed!

INSTALLATION PRECAUTIONS

The main cause of ignition damage is a high voltage flashover to ignition system wiring!

The fast rise time of CDI ignition output voltage increases the propensity for insulation breakdown in high voltage components therefore greater care must be taken with regards to cleanliness and wiring detail to prevent this occurring.

IGNITION COIL SELECTION

For ultimate ignition energy use coils specifically designed for CDI use such as the M&W #COI006. Ignition coils primarily designed for inductive ignition will significantly limit CDI output.

COIL POLARITY

All diagrams are shown for cdi style coils. For correct operation with inductive ignition coils wire the primary connections in reverse to maintain correct spark plug polarity and overcome any blocking diode.

M & W IGNITIONS

Performance & Quality

CAUTION!
HIGH VOLTAGE



**DISCONNECT POWER BEFORE
WORKING ON UNIT**

VIEWED FROM BACK OF CONNECTOR



SPECIFICATIONS

Operating voltage	12.5V --> 18V DC
Polarity	Negative ground
Startup voltage	>= 6V
Maximum supply current	7.0A
Power off current	< 700uA
Maximum ignition frequency	1,200Hz
Energy limit:	700Hz
Coil primary voltage	480V
Spark energy er	115mJ
Trigger:	
Voltage (min)	250mV AC
Voltage (max)	200V AC
Location	Negative crossing
Tacho output:	
Voltage	Supply - 1.2V
Output current	100mA
Shape	Square wave
Operating temperature	<= 105°C
Dimensions	112L * 110W * 40H
Weight	560gm

1 +12V (Battery)	7 Ground (Battery)	13
2 +12V (Battery)	8 Ground (Battery)	14 Reluctor -
3 High Speed Kill	9	15 Reluctor +
4 Tacho	10	16 Ignition switch
5	11	17
6 Coil +	12	18 Coil -

Title			PRO-10RALK CDI		
Size	Number		Revision		
A4	(C) M&W Ignitions		28.09.21.1		
Date:	28-Sep-2021	Sheet	1	of	1
File:	D:\M&W\Pro10RALK S3 1.sch	Drawn By:	WAG		

Wire Specifications

POWER SUPPLY:

Use 14ga wire from battery bifurcated into 20ga wire <= 100mm from connector. Junction is best achieved using a Solistrand or similar butt splice / barrel crimp. Maximum recommended wire length is 2M

IGNITION COILS:

Use 20ga wire from cdi to coils and keep as one continuous length. Maximum recommended wire length is 2M

Read installation guide for important wiring details!

M & W IGNITIONS

Performance & Quality

**CAUTION!
HIGH VOLTAGE**



DISCONNECT POWER BEFORE WORKING ON UNIT

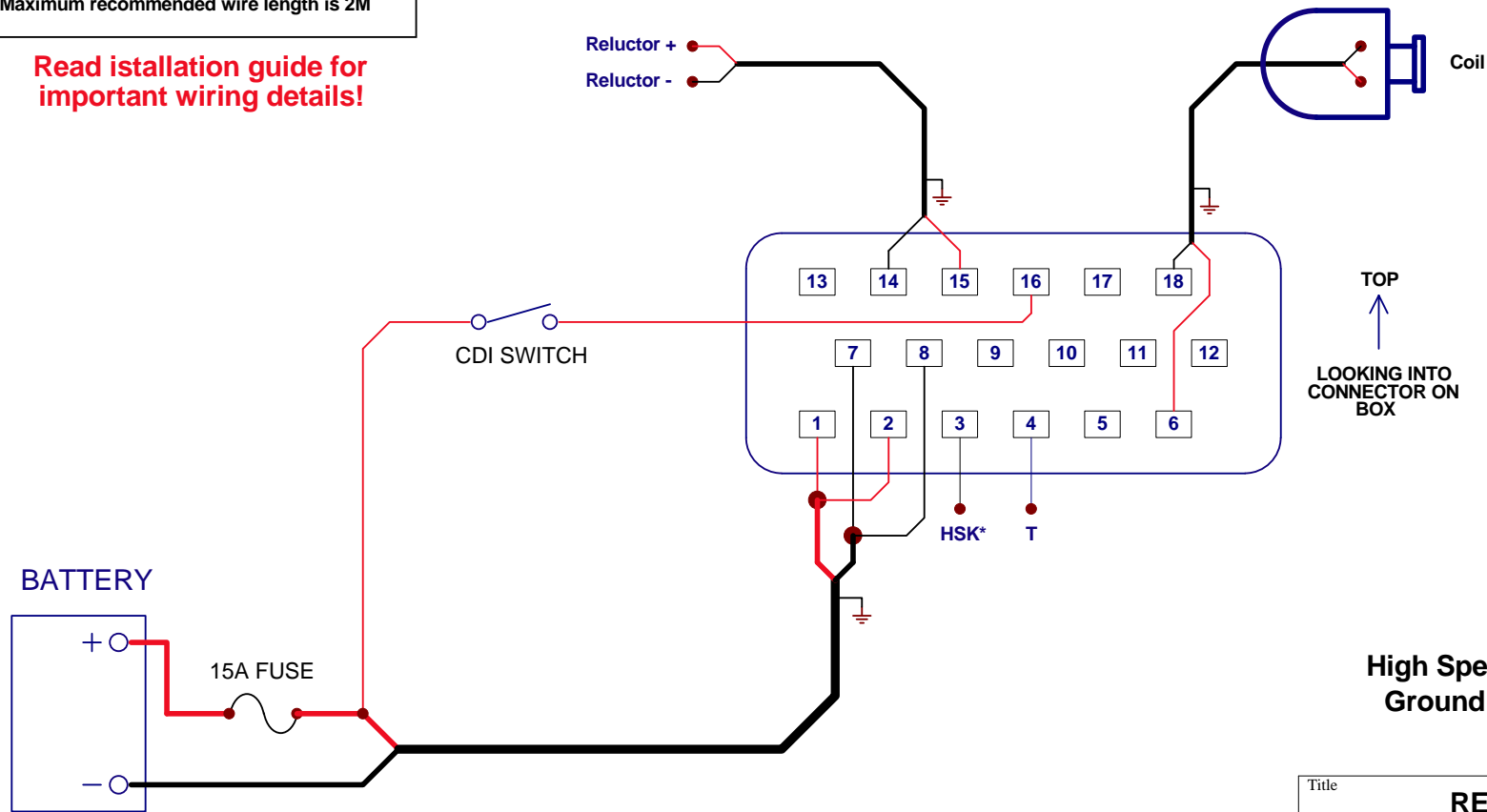

TOP
↑
LOOKING INTO CONNECTOR ON BOX

Note*
High Speed Kill function is active low
Ground input to interrupt ignition

Title			RELUCTOR TRIGGER CDI		
Size	Number	Revision			
A4	(C) M&W Ignitions	28.09.21.1			
Date:	28-Sep-2021	Sheet	1	of 1	
File:	D:\M&W\...\Pro10RALK S3 2.sch	Drawn By:	WAG		

M & W IGNITIONS

Performance & Quality

CYL SWITCH	# ENGINE CYLINDERS
0	
1	
2	
3	
4	4
5	
6	6
7	
8	8
9	
A	10
B	
C	12
D	
E	
F	



OPERATION

Limiting range - 2,000 to 19,900 in 100 rpm increments
 To disable rpm limiting select 'zero' for all 'RPM' switches
 CDI power switch must be cycled after making changes to 'CYL' switch
 Engine RPM switches may be changed at any time

WARNING!

**Engines respond differently to RPM limiting
 Set conservative limit at first then increase to desired
 maximum rpm after observing engine response**

Title			REV LIMITER		
Size	Number	Revision			
A4	(C) M&W Ignitions	16.09.18.1			
Date:	16-Sep-2018	Sheet	1	of 1	
File:	D:\M&W\...\Pro10R S3 limiter.sch	Drawn By:	WAG		

M & W IGNITIONS

Performance & Quality

CAUTION!
HIGH VOLTAGE



**DISCONNECT POWER BEFORE
WORKING ON UNIT**

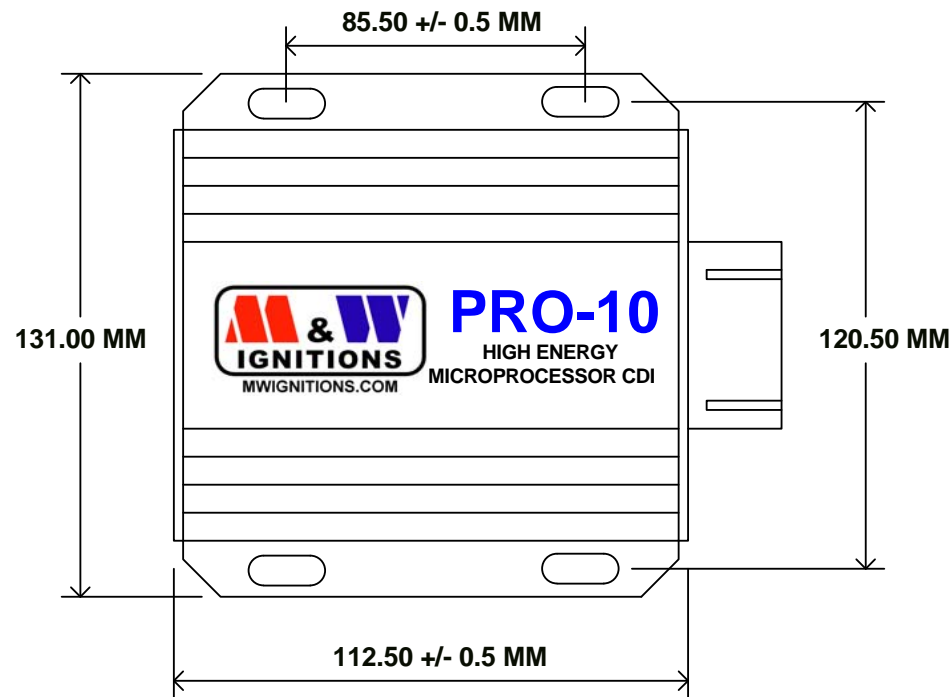

Slot dimensions - 5mm * 10mm

Title			
PRO-10RL MOUNTING DIMENSIONS			
Size	Number	Revision	
A4	(C) M&W Ignitions	11.12.17.1	
Date:	11-Dec-2017	Sheet 1 of	1
File:	D:\M&W\Pro-10RL dimensions.sch	Drawn By:	WAG