



Pro-Drag2

160/250mJ S3

ELECTRICAL WIRING & OPERATING INSTRUCTIONS

Applicable
S/No's 37xxxx

**FAILURE TO FOLLOW INSTRUCTIONS
WILL VOID WARRANTY**

CONTENTS:

2. Installation notes
6. Connections and specifications
7. Two channel ignition
8. Mounting dimensions

**ADDITIONAL RESOURCES & UP TO DATE
INSTRUCTIONS AVAILABLE FROM WEBSITE**

INSTALLATION NOTES

(Pro-Drag 250mJ Series 3 systems)

MOUNTING

Mount the unit in a dry location away from intense heat and ensure bottom condensation slots are unobstructed and oriented to permit gravity drain. Ensure a source of cooling air is available.

Failure to use supplied rubber mounts will void warranty!

IGNITION LEADS

Use inductively suppressed spiral wound metal conductor ignition leads.

Do not use carbon core or unsuppressed metal leads!

SPARK PLUGS

Non resistor spark plugs will greatly enhance ignition performance however some installations will require the use of resistor spark plugs for correct ECU operation.

When using resistor spark plugs it is imperative to check internal resistance as part of regular maintenance!

Open circuit or high resistance may cause damage to spark plug wires, ignition coils and CDI.

Fixed gap surface discharge and semi surface discharge spark plugs are only suitable for naturally aspirated applications.

Keep spark plug gap ≤ 0.025 " (0.6mm) for boosted motors to prevent coil and CDI damage!

INSULATION PRECAUTIONS

Degrease sparkplug insulators, sparkplug boots, ignition coil boots and installation tooling to prevent insulation breakdown.

Use supplied dielectric grease on sparkplug insulators and inside sparkplug and ignition coil boots to aid installation/removal and help prevent high voltage flashover.

POWER SUPPLY

Do not use voltage boosters, if the vehicle contains a PDM use it only to control CDI switch wire.

Connect ignition supply wires directly to battery!

When using a total loss electrical system install either a 16V or 18V battery to ensure adequate voltage and isolate when charging.

WIRING

If required power/ground wire length exceeds recommendations use paired battery cable (power and ground) to make up distance. Do not rely on vehicle chassis to provide ground path.

Use twisted pair wire for all power and coil connections. For improved noise suppression or to comply with EMC requirements use twisted shielded wire similar to M27500 series.

M&W CDI systems will open circuit the external fuse if over voltage conditions are experienced. Faults such as loose battery terminals/wiring or defective alternator/regulator may also cause this to occur.

Main connector pins are designed for roll crimping. Squeeze crimping or soldering will distort pins resulting in misfiring or incorrect CDI operation. Use of dielectric grease in main connector may help reduce water ingress.

Common coil negative wires must be joined at or in the cdi connector.

Keep coil primary wires well separated from HT leads, coil HV outlet, coil body and any ECU wiring!

TRIGGERING

For correct operation trigger voltage relative to CDI ground must rise above 3.2V and fall below 1.6V.

Single box: Ignition channels may be triggered in any sequence.

Two box: Firing sequence must alternate between boxes (except Mazda rotary applications where one box is used for leading sparkplugs and other for trailing sparkplugs).

250mJ S3 Pro-Drag systems with a trigger edge selection input default to falling (negative) edge trigger. To select rising edge (positive) trigger ground 'Trigger Edge' pin.

Some 250mJ S3 Pro-Drag systems with a power level switch input are fixed falling (negative) edge ignition unless a trigger edge selection input is also shown on installation drawing.

If uncertain lock Ecu timing and monitor engine with timing light while changing RPM. Timing should appear stationary with correct trigger edge.

Trigger input & coil output letters (or numbers) indicate CDI firing sequence not cylinder number.

POWER LEVEL SWITCH

To reduce ignition energy under low load conditions some M&W 250mJ S3 units include an (active low) power level switch.

Do not manually activate this feature. Install an adjustable 'Hobbs' style manifold pressure switch or use a programmable output from the ECU to ground the input when engine comes under load.

TUNING

CDI performance is not affected by changes in dwell settings!

M&W CDI systems may reduce ignition delay requiring a reduction in timing. The resulting changes in combustion characteristics may also require alterations to fuel flow.

Always set ECU ignition delay to zero and re-tune both fuel and timing curves after installation!

TACHO OUTPUT

Tacho output provides a 50% duty cycle square wave signal approximately 1V below supply voltage. This will work with most aftermarket digital tacho's however some earlier types and those

designed for coil negative triggering may not read accurately and require an adaptor.

LED INDICATOR

After applying power to input switch wire the LED will illuminate for approximately 1 second then extinguish. It will then flash briefly with each consecutive trigger event received.

A repeated double flash of the LED may indicate a possible faulty ignition coil, faulty wiring, low supply voltage or damage to the CDI.

TESTING

The CDI may be tested by momentarily grounding the trigger inputs which will cause the LED to flash and corresponding ignition coil to spark.

Do not conduct this test without grounded spark plugs installed!

COIL SELECTION

For ultimate ignition energy use coils specifically designed for CDI use such as the M&W #COI006. Ignition coils primarily designed for inductive ignition will significantly limit CDI output.

Wire inductive coils reverse polarity when used with M&W CDI's.

Do not use AEM pencil coils or Prufex brand ferrite coils under any circumstances!

COP COILS

Use COP coils at your own risk with 250mJ S3 systems as coil failure & breakdown may occur damaging CDI unit.

Use of resistor spark plugs with COP coils is mandatory and plug gap must be kept below 0.020" (0.5mm)!

FERRITE CDI COILS

Ferrite core cdi coils emit high levels of EMI requiring additional shielding practices and are unsuitable for use with alcohol based fuels.

Do not use ferrite coils wired in parallel pairs!

M & W IGNITIONS

Performance & Quality since 1996

VIEWED FROM BACK OF CONNECTOR



1 +12V (Battery)	7 Ground (Battery)	13 Power (P)*
2 +12V (Battery)	8 Ground (Battery)	14 Trigger B
3	9 Trigger edge	15 Trigger A
4 Tacho (T)	10 Signal ground	16 Ignition switch
5	11	17 Coil A -
6 Coil A +	12 Coil B +	18 Coil B -

* Power level switch only on S/No's 370448 and above!

SPECIFICATIONS

Operating voltage	12.5V -> 18V DC
Polarity	Negative ground
Startup voltage	>= 6V
Maximum supply current	18A
Power off current	< 700uA
Maximum ignition frequency	750Hz
Energy limit:	1,100Hz
Coil primary voltage:	
Lo power	460V
Hi power	540V
Spark energy:	
Lo power	160mJ
Hi power	250mJ
Trigger:	
Current	10mA
Edge	Adjustable
Voltage rising	>= 3.2V
Voltage falling	<= 1.6V
Tacho output:	
Voltage	Supply - 1.2V
Output current	100mA
Shape	Square wave
Operating temperature	<= 105°C
Dimensions	112L * 110W * 40H
Weight	570gm (per box)

Title			TWO CHANNEL IGNITION		
Size	Number	(C) M&W Ignitions		Revision	06.04.20.1
A4					
Date:	6-Apr-2020	Sheet 1 of 1			
File:	D:\M&W\...\Pro-Drag2_S3_1.sch	Drawn By: M&W			

Wire Specifications

POWER SUPPLY:

Use 14ga wire from battery bifurcated into 20ga wire <= 100mm from connector. Junction is best achieved using a Solistrand or similar butt splice / barrel crimp. Maximum recommended wire length is 2M

IGNITION COILS:

Use 20ga wire from cdi to coils and keep as one continuous length. Maximum recommended wire length is 2M

Mazda 2 Rotor

Two boxes required for Mazda 13B 2 rotor. Wire one box to fire both leading plugs and the other to fire both trailing plugs

Read installation guide for important wiring details!

M & W IGNITIONS

Performance & Quality

**CAUTION!
HIGH VOLTAGE**



**DISCONNECT POWER BEFORE
WORKING ON UNIT**

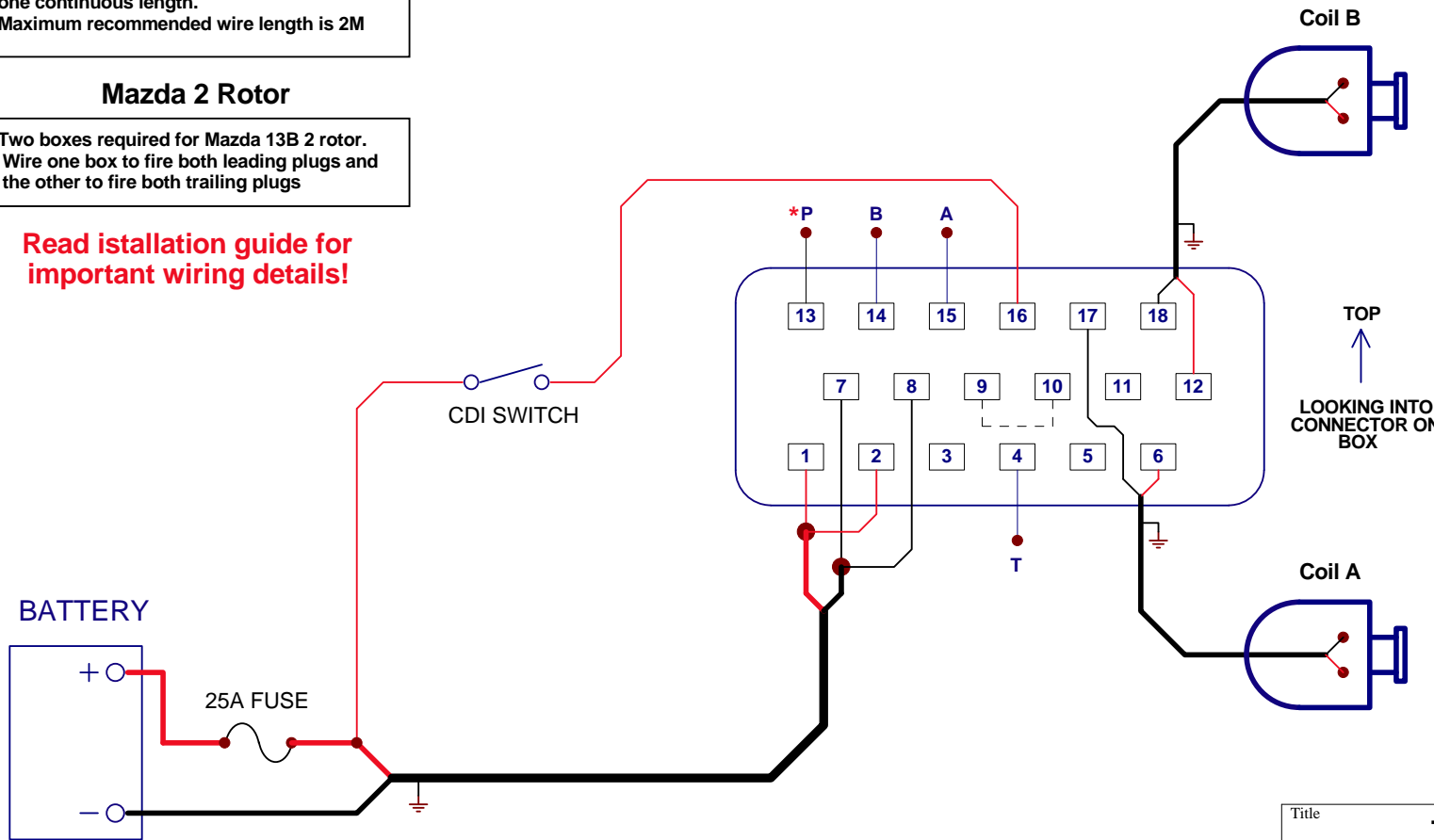

*** Power level switch only on S/No's 370448 and above!**

Title		TWO CHANNEL IGNITION	
Size	Number	Revision	
A4	(C) M&W Ignitions	01.08.19.1	
Date:	1-Aug-2019	Sheet 1 of 1	
File:	D:\M&W\...\Pro-Drag2_S3_2.sch	Drawn By:	WAG

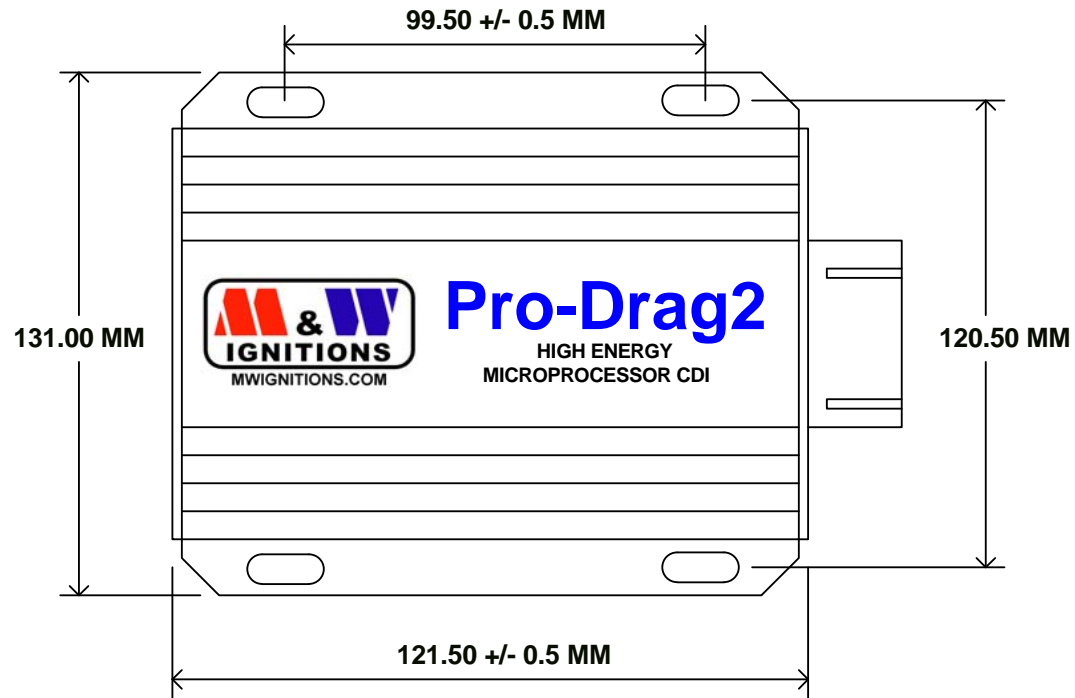

Pro-Drag2
HIGH ENERGY
MICROPROCESSOR CDI

Slot dimensions - 5mm * 10mm

Title		MOUNTING DIMENSIONS	
Size	Number	Revision	
A4	(C) M&W Ignitions	08.06.13.1	
Date:	4-Jul-2019	Sheet 1 of 1	
File:	D:\M&W\...\Mounting Dimensions.sch	Drawn By:	M&W