



Pro-Drag4

500mJ S4

ELECTRICAL WIRING & OPERATING INSTRUCTIONS

Applicable
S/No's 85xxxx

**FAILURE TO FOLLOW INSTRUCTIONS
WILL VOID WARRANTY**

CONTENTS:

2. Installation notes
6. Connections and specifications
7. 4 coil sequential ignition
8. Mounting dimensions

Scan to download
current instructions



INSTALLATION NOTES

(Pro-Drag 500mJ Series 4 systems)

MOUNTING

Mount the unit in a dry location away from intense heat and ensure bottom condensation slots are unobstructed and oriented to permit gravity drain. Ensure a source of cooling air is available.

Failure to use supplied rubber mounts will void warranty!

IGNITION LEADS

Use inductively suppressed spiral wound metal conductor ignition leads.

Do not use carbon core or unsuppressed metal leads!

SPARK PLUGS

Non resistor spark plugs will greatly enhance ignition performance however some installations will require the use of resistor spark plugs for correct ECU operation.

When using resistor spark plugs it is imperative to check internal resistance as part of regular maintenance!

Open circuit or high resistance may cause damage to spark plug wires, ignition coils and CDI.

Fixed gap surface discharge and semi surface discharge spark plugs are only suitable for naturally aspirated applications.

Keep spark plug gap ≤ 0.025 " (0.6mm) for boosted motors to prevent coil and CDI damage!

INSULATION PRECAUTIONS

Degrease sparkplug insulators, sparkplug boots, ignition coil boots and installation tooling to prevent insulation breakdown.

Use supplied dielectric grease on sparkplug insulators and inside sparkplug and ignition coil boots to aid installation/removal and help prevent high voltage flashover.

POWER SUPPLY

REVERSE POLARITY WILL DAMAGE UNIT! ALWAYS INSTALL EXTERNAL FUSE!

Do not use voltage boosters, if the vehicle contains a PDM use it only to control CDI switch wire.

Connect ignition supply wires directly to battery!

When using a total loss electrical system install either a 16V or 18V battery to ensure adequate voltage and isolate when charging.

WIRING

If required power/ground wire length exceeds recommendations use paired battery cable (power and ground) to make up distance. Do not rely on vehicle chassis to provide ground path.

Use twisted shielded pair wire for all power and coil connections such as aerospace M27500 series.

M&W CDI systems will open circuit the external fuse if over voltage or reverse polarity conditions are experienced. Faults such as loose battery terminals/wiring or defective alternator/regulator may also cause this to occur.

Main connector pins are designed for roll crimping. Squeeze crimping or soldering will distort pins resulting in misfiring or incorrect CDI operation. Use of dielectric grease in main connector may reduce water ingress.

Keep coil primary wires well separated from HT leads, coil HV outlet, coil body and any ECU wiring!

TRIGGERING

For correct operation trigger voltage relative to CDI ground must rise above 3.2V and fall below 1.6V.

Single box: Ignition channels may be triggered in any sequence.

Two box: Firing sequence must alternate between boxes.

500mJ S4 Pro-Drag systems include a trigger edge selection input which defaults to falling (negative) edge trigger. To select rising edge (positive) trigger join 'Trigger Edge' and 'Edge Ground' pins.

If uncertain lock Ecu timing and monitor engine with timing light while changing RPM. Timing should appear stationary with correct trigger edge.

Trigger input & coil output letters (or numbers) indicate CDI firing sequence not cylinder number.

POWER LEVEL SWITCH

M&W 500mJ S4 ignition systems include a power level switch to reduce ignition energy under low engine load conditions.

Activate high power by grounding input through either a 'Hobbs' style manifold pressure switch or programmable output from the ECU when increased ignition energy is required.

Do not manually or permanently activate this feature!

TUNING

CDI performance is not affected by changes in dwell settings!

M&W CDI systems may reduce ignition delay requiring a reduction in timing. The resulting changes in combustion characteristics may also require alterations to fuel flow.

Always set ECU ignition delay to zero and re-tune both fuel and timing curves after installation!

TACHO OUTPUT

Tacho output provides a 50% duty cycle square wave signal approximately 1V below supply voltage. This will work with most aftermarket digital tacho's however some earlier types and those designed for coil negative triggering may not read accurately and require an adaptor.

LED INDICATOR

After applying power to switch wire both the red and green LED's will illuminate for approximately 1 second.

The green led will then extinguish and flash briefly with each trigger event received

The red led will illuminate when high power mode is selected.

A repeated double flash may indicate a faulty ignition coil, faulty wiring, low supply voltage or damage to the CDI.

TESTING

The CDI may be tested by momentarily grounding the trigger inputs which will cause the LED to flash and corresponding ignition coil to spark.

Do not conduct this test without grounded spark plugs installed!

COIL SELECTION

Use only high quality cdi specific coils such as the M&W COI006.

Do not use with COP coils

Do not use with pencil coils

Do not use with ferrite core coils such as Mercury or Profex

M & W IGNITIONS

Performance & Quality

CAUTION!
HIGH VOLTAGE



**DISCONNECT POWER BEFORE
WORKING ON UNIT**

VIEWED FROM BACK OF CONNECTOR



SPECIFICATIONS

Operating voltage	12.5V → 18V DC
Polarity	Negative ground
Startup voltage	≥ 6V
Maximum supply current	25A
Power off current	< 700uA
Maximum ignition frequency	625 Hz
Energy limit:	
Single spark	500 Hz
Coil primary voltage:	
Low power	400V
High power	500V
Spark energy (per plug):	
Low power	320mJ
High power	500mJ
Trigger:	
Current	10mA
Edge	Adjustable
Voltage rising	≥ 3.2V
Voltage falling	≤ 1.6V
Tacho output:	
Voltage	Supply - 1.2V
Output current	100mA
Shape	Square wave
Operating temperature	≤ 105°C
Dimensions	173L * 137W * 50H
Weight	1,030gm (per box)

1 +12V (Battery)	13 Ground (Battery)	25 Trigger A
2 +12V (Battery)	14 Ground (Battery)	26 Ignition switch
3 +12V (Battery)	15 Ground (Battery)	27 Trigger B
4 +12V (Battery)	16 Ground (Battery)	28 Trigger C
5 Trigger edge	17 Edge ground	29 Trigger D
6 Tacho (T)	18	30
7	19	31 Power (P)
8	20	32
9	21 Coil D -	33
10 Coil C +	22 Coil C -	34 Coil D +
11	23 Coil A -	35
12 Coil A +	24 Coil B -	36 Coil B +

Title			PRO-DRAG4 500mJ SERIES 4
Size	Number	Revision	
A4	(C) M&W Ignitions	11.04.17.1	
Date:	1-Mar-2018	Sheet 1 of 1	
File:	D:\M&W\...\Pro-Drag4 500 S4 1.sch	Drawn By:	WAG

Wire Specifications

POWER SUPPLY:

Use 12ga shielded wire from battery quadfurcated into 18ga wire <= 100mm from connector. Junction is best achieved using a Solistrand or similar butt splice / barrel crimp.

Maximum recommended wire length is 2M

IGNITION COILS:

Use 18ga shielded wire from cdi to coils and keep as one continuous length.

Maximum recommended wire length is 2M

Read installation guide for important wiring details!

M & W IGNITIONS

Performance & Quality

**CAUTION!
HIGH VOLTAGE**



DISCONNECT POWER BEFORE WORKING ON UNIT

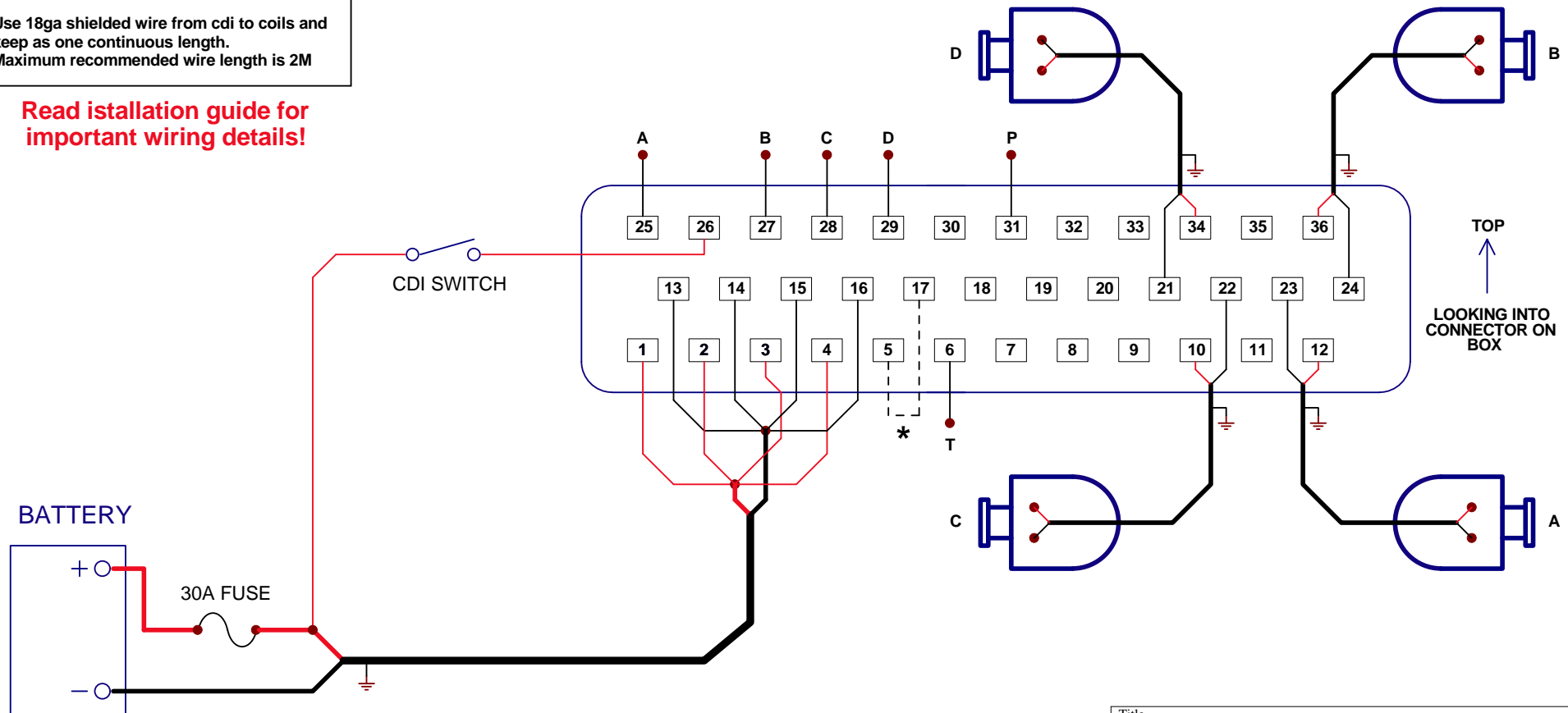

TOP
↑
LOOKING INTO CONNECTOR ON BOX

Reverse polarity connection without fuse installed will damage unit!

* See installation instructions

Title			4 CYLINDER DIRECT FIRE WIRING		
Size	Number	Revision			
A4		(C) M&W Ignitions		22.09.16.1	
Date:	2-Jul-2019	Sheet 1 of	1		
File:	D:\M&W\...\Pro-Drag4 500 S4 2.sch	Drawn By:	WAG		

CAUTION!
HIGH VOLTAGE



**DISCONNECT POWER BEFORE
WORKING ON UNIT**

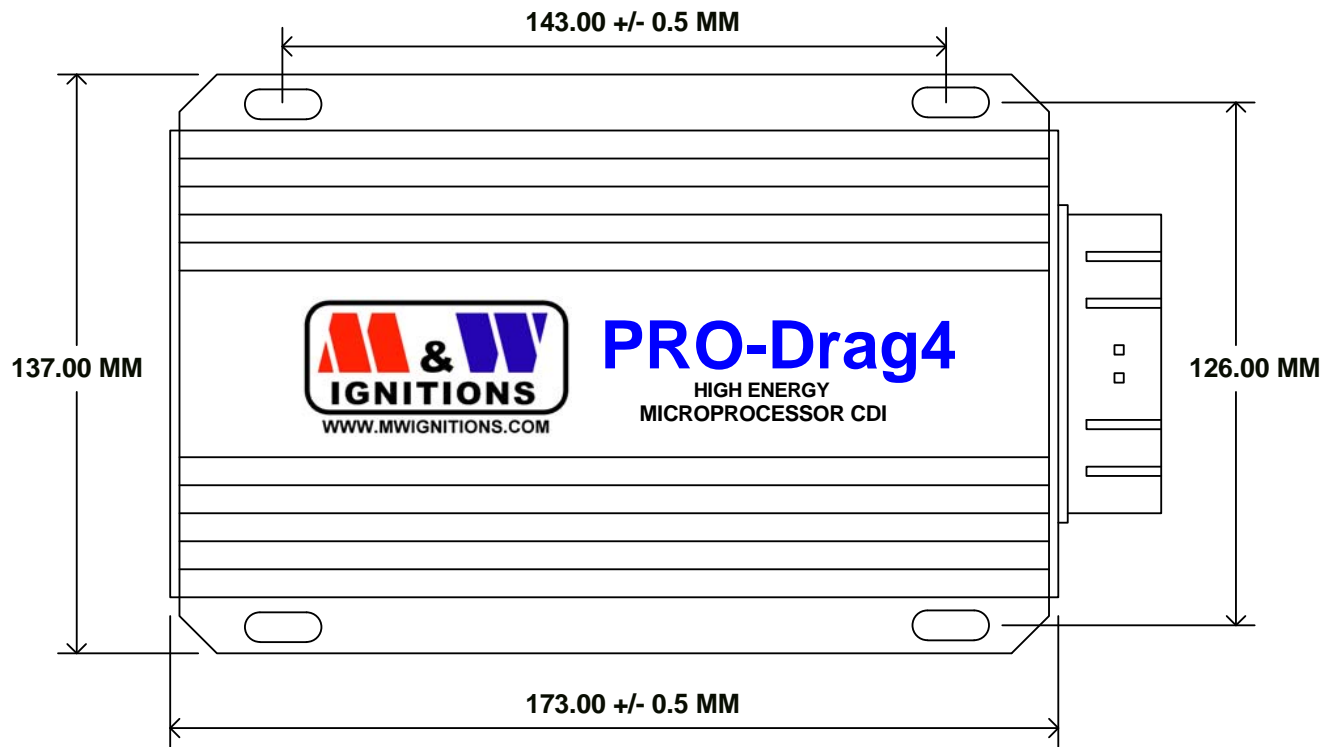

PRO-Drag4
HIGH ENERGY
MICROPROCESSOR CDI

Slot dimensions - 5mm * 10mm

Title			PRO-DRAG4 500mJ SERIES 4
Size	Number	Revision	
A4	(C) M&W Ignitions	22.10.16.1	
Date:	22-Oct-2016	Sheet 1 of 1	
File:	D:\M&W\...\Pro-Drag4 500 S4 dimensions.dwg		Drawn By: WAG