



Pro-Drag4

4 channel 250mJ

CAPACITOR DISCHARGE

IGNITION

PLEASE REPORT ANY ERRORS
SALES@MWIGNITIONS.COM

CONTENTS:

2. Caution
3. Installation notes
7. Ignition coil information
8. Mounting dimensions
9. Connections and specifications
10. 4 Channel sequential ignition
11. 3 Rotor Mazda sequential ignition
12. Shielding & EMC compliance

**CHECK WEBSITE FOR CURRENT INFORMATION &
ADDITIONAL INSTRUCTIONS**

CAUTION

**THIS WIRING DIAGRAM IS
APPLICABLE ONLY TO IGNITION
SYSTEMS WITH SERIAL NUMBER
PREFIX STARTING**

35xxxx

**USE OF INCORRECT DIAGRAM WILL
VOID WARRANTY AND MAY DAMAGE
UNIT**

**THE INSTALLATION OF HIGH ENERGY IGNITION
SYSTEMS MAY REQUIRE ADVANCED
KNOWLEDGE AND SKILLS.**

**IMPROPER INSTALLATION OR OPERATION OF
THIS UNIT COULD CAUSE DAMAGE TO IGNITION
SYSTEM AND IGNITION COIL**

INSTALLATION NOTES

(Pro-Drag 250mJ systems only)

MOUNTING

Do not mount the unit where it will be exposed to water or other liquids and ensure the bottom condensation slots are unobstructed and permit gravity draining. Select a location away from intense heat such as turbochargers and exhaust pipes. Provide a source of cooling air to remove any internally generated heat.

FAILURE TO USE SUPPLIED RUBBER MOUNTS WILL VOID WARRANTY!

Suitable anti vibration mounts should be no stiffer than 40 Duro such as M&W #MNT002, Paulstra Radiaflex #521128, Farnell Components (Element14) #7107821, Newark #70C1626 or RS Components #254-7444

IGNITION LEADS

Do not use either straight metal wire ignition leads or carbon core ignition leads.

For best performance use spiral wound inductively suppressed metal core ignition leads such as those produced by [Magnecor®](#).

SPARK PLUGS

The use of use non resistor spark plugs (where possible) will significantly increase coil to fuel energy transfer.

When using resistor spark plugs ensure they are not damaged internally by regularly measuring resistance value. Open circuit or high resistance may cause failure of spark plug wires, ignition coils and CDI.

Do not use surface discharge or semi surface discharge spark plugs as they contain excessively large non adjustable spark gaps.

INSULATION PRECAUTIONS

Always degrease spark plug insulators and boots after handling to prevent insulation breakdown through contamination

Use supplied dielectric grease on spark plug insulators and coil boots to significantly improve insulation properties and ease installation and removal. Use in main connector can also help reduce issues due to water ingress.

WIRING & POWER SUPPLY

M&W CDI systems contain internal protective mechanisms designed to blow the external fuse under conditions of over voltage or reverse polarity. In the event this does occur fitting a larger size fuse will not solve the problem, will void warranty and may make the unit irreparable.

Faults such as a loose battery terminals, poor wiring or faulty alternator/regulator may cause momentary over voltage spikes sufficient enough to blow the fuse.

Main connector pins are designed to be roll crimped not squeeze crimped or soldered. Distortion of pins during crimping and assembly may cause misfiring or incorrect operation of CDI.

Wire ignition system directly to the battery. If wire length exceeds recommendations use larger paired battery cables (power and ground) to make up distance. Do not rely on vehicle chassis to provide ground. If connected to a high impedance supply shared with the ECU or its sensors erratic operation will be experienced.

Do not operate below 13V. If the electrical system has no means of charging use either a 16V or 18V battery to ensure sufficient voltage supply to cdi.

Do not use voltage boosters as voltages above 13.5V provide no additional performance and most can not provide sufficient instantaneous current required for correct CDI operation.

When using extended voltage batteries disconnect the battery during charging to prevent excessive voltage (>22V) reaching the CDI as this may blow the fuse.

Use twisted shielded pair wire for all coil connections. Twisted pair wire may be used for power/ground.
Keep coil wires one continuous length from CDI, do not fit intermediate connector into harness.

All coil negative wires must be joined at or in the cdi connector.

TRIGGERING

Trigger input & coil output numbers or letters indicate CDI ignition sequence not cylinder number.

250mJ Pro-Drag systems include a selective trigger edge input which defaults to falling edge ignition when no jumper is installed. To select rising edge ignition install a jumper wire between 'Trigger Edge' and 'Signal Ground' pins.

Where the ECU contains an inbuilt igniter it may be necessary to invert the cdi trigger edge selected.

Trigger edge on the CDI must be set same as that in the ECU!

POWER LEVEL SWITCH

Ignition system have no means of detecting engine load and provide maximum performance whether the engine is being free revved or under full load.

Some 250mJ units include a power level switch to allow for reduction of ignition energy during low load conditions.

Do not manually activate the power switch. Either install an adjustable 'Hobbs' style pressure switch in the inlet manifold or use a programmable output from the ECU and wire so input is grounded to select high power when engine starts to come on load.

IGNITION TIMING

M&W high power CDI ignition systems will typically change the engine combustion characteristics and may require significantly less total timing.

Always re tune both fuel and ignition systems after installing CDI ignition.

TACHO OUTPUT

The M&W tachometer output provides a 50% duty cycle square wave signal at battery supply voltage. This will work with most aftermarket digital tachometers however earlier types and those designed to trigger from a coil negative signal may not read accurately.

LED INDICATOR

After initially applying power to the CDI the LED will illuminate for 1 second then extinguish. The LED will then flash briefly with each consecutive trigger event received (it may be necessary to view the LED directly on axis).

A repeated double flash of the LED indicates a possible faulty ignition coil, faulty wiring, low supply voltage or damage to the CDI. See test procedure below

TESTING

The CDI may be tested by momentarily grounding the trigger inputs which will cause the LED to flash and corresponding ignition coil to spark. **Do not conduct this test without grounded spark plugs installed!**

A more comprehensive test procedure may be found on our web site http://www.mwignitions.com/pg_data_sheets.php

SAFETY

Due to the extreme energy and voltage levels developed by M&W 250mJ ignition systems it is strongly recommended certain procedures be followed to ensure safety of mechanics and prevent ignition component damage.

1. Install dummy, grounded, metal spark plugs in the engine bay and transfer the spark plug leads to these between race events or at least when working on engine.
2. Install an aircraft style guarded toggle switch in the CDI ignition switch wire circuit and habitually disable it when not actually running the engine.

For further instructions and CDI information check out the support tab on our web site

<http://www.mwignitions.com>

IGNITION COILS

(Pro-Drag systems only)

COIL SELECTION

For ultimate ignition energy and efficiency use coils specifically designed for CDI use. Use of ignition coils designed for inductive ignition will greatly limit ignition (spark) energy.

COP COILS

COP (coil on plug) coils were not designed for the energy levels developed by M&W Pro-Drag systems.

Use COP coils at own risk with 250mJ systems due to possibility of exceeding insulation limits, DO NOT use with 500mJ systems.

Use resistive spark plugs with all COP coils. Keep plug gap < 0.025" (0.6mm) to prevent coil damage.

DO NOT use AEM pencil coils under any circumstances!

FERRITE CDI COILS

Ferrite core cdi coils provide a lightweight solution for direct fire applications and give high secondary current however they may not be suitable for all applications due to their extremely short arc duration. The high level of EMI emitted by these coils may also require additional shielding to prevent electrical interference with the ECU or CDI. **Do not use ferrite coils in parallel wired pairs!**

CAUTION!

**IGNITION COIL DAMAGE MAY OCCUR IF
OPERATED WITH AN EXCESSIVE SPARK GAP**



DISCONNECT POWER BEFORE WORKING ON UNIT

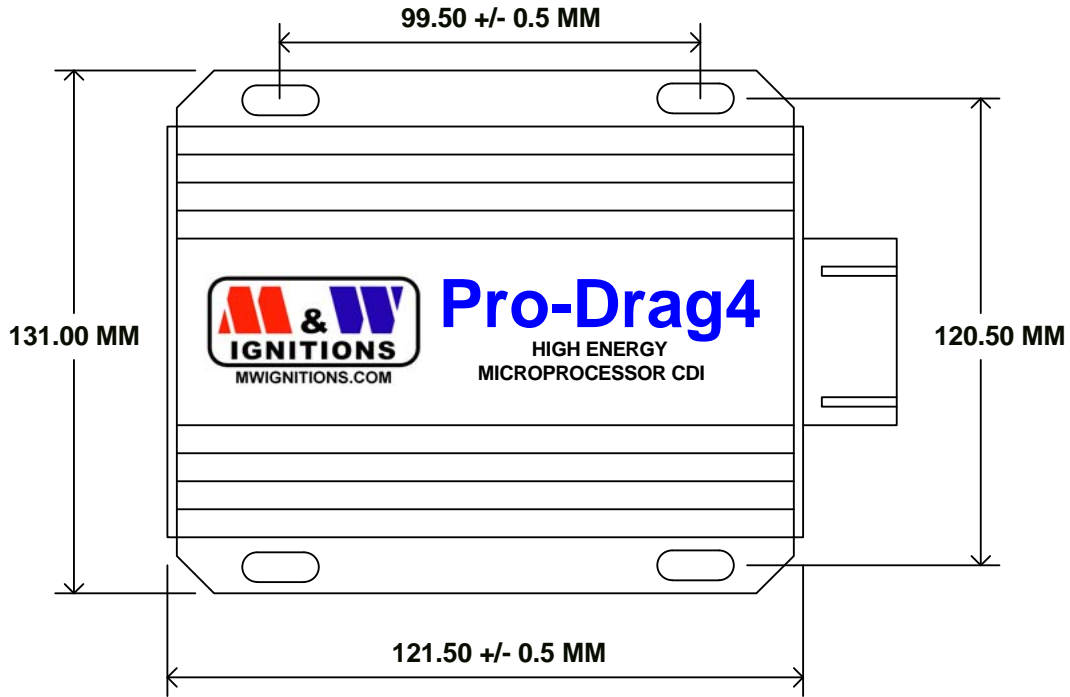

Pro-Drag4
HIGH ENERGY
MICROPROCESSOR CDI

Slot dimensions - 5mm * 10mm

Title			MOUNTING DIMENSIONS		
Size	Number	Revision			
A4	Pro-Drag4 S3	25.04.13.1			
Date:	25-Apr-2013	Sheet 1 of	1		
File:	D:\M&W\Pro-Drag4_S3_Mounting dimensions		Drawn By:	M&W	

M & W IGNITIONS

Performance & Quality since 1996

**CAUTION!
HIGH VOLTAGE**



**DISCONNECT POWER BEFORE
WORKING ON UNIT**

VIEWED FROM BACK OF CONNECTOR



KEEP ALL INPUTS WELL SEPARATED FROM COIL OUTPUTS

1 +12V (Battery)	7 Ground (Battery)	13 Trigger D
2 +12V (Battery)	8 Ground (Battery)	14 Trigger B
3 Trigger C	9 Trigger edge	15 Trigger A
4 Tacho	10 Signal Ground	16 Ignition switch
5 Coil C +	11 Coil B +	17 Coils C & D -
6 Coil A +	12 Coil D +	18 Coils A & B -

SPECIFICATIONS

Supply voltage = 13.8V DC negative ground
 Minimum voltage for starting = +11V
 Normal operating voltage +13V to +18V
 Maximum supply current = 20A
 Shutdown current <700uA
 Maximum ignition frequency =600Hz
 Coil primary voltage = 500V
 Spark energy = 250 millijoules
 Trigger = 10mA open collector drive
 Tacho = 12V, 100mA square wave
 Maximum continuous temperature = 105°C
 Dimensions = 122L * 110W * 40H
 Weight = 800gm

Title FOUR CHANNEL 250mJ CDI IGNITION		
Size A4	Number Pro-Drag4 S3	Revision 25.04.13.1
Date: 25-Apr-2013	Sheet1 of 1	Drawn By: M&W
File: D:\M&W\Pro-Drag4_S3_1.sch		

M & W IGNITIONS

Performance & Quality since 1996

FOR DRAG RACING USE ONLY

CAUTION!
HIGH VOLTAGE



DISCONNECT POWER BEFORE WORKING ON UNIT

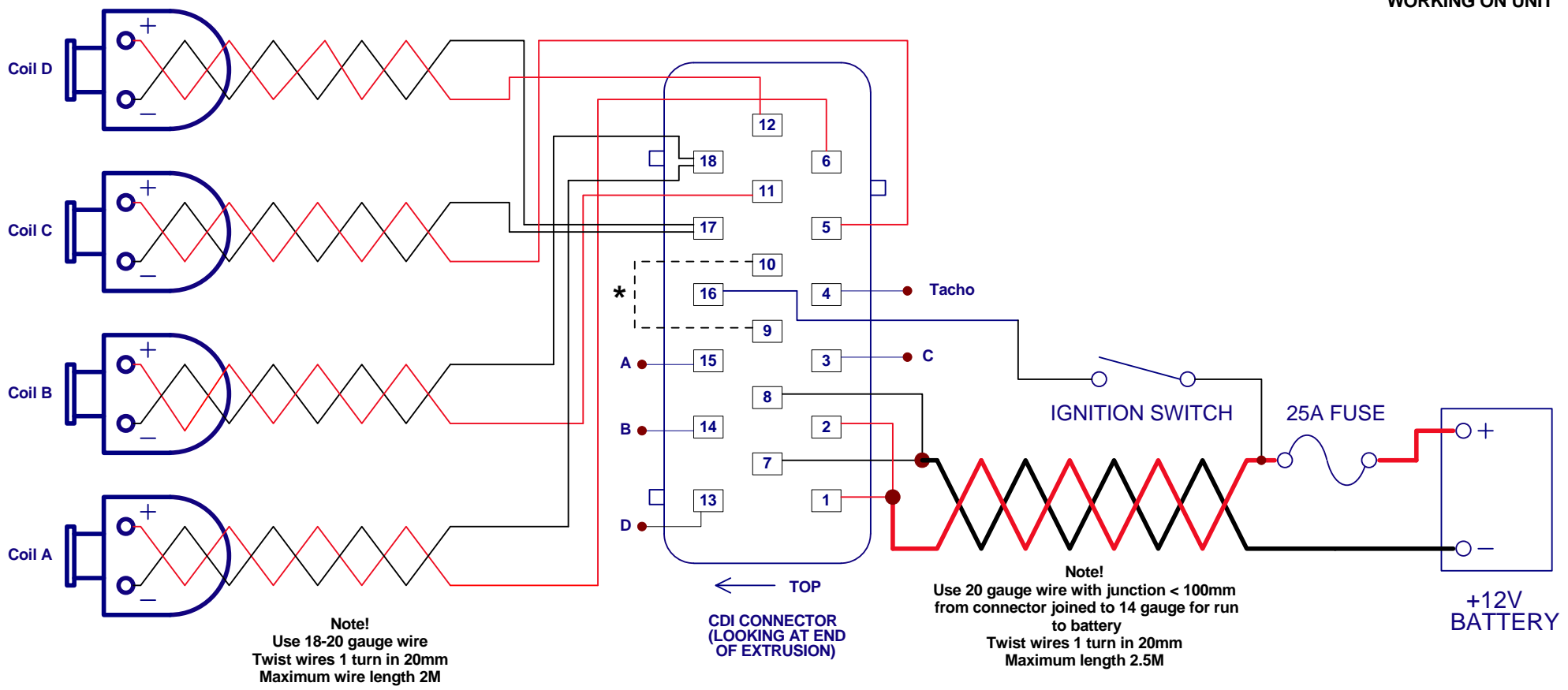

* See installation instructions for trigger edge selection

Title			FOUR CHANNEL SEQUENTIAL IGNITION		
Size	Number	Revision			
A4	Pro-Drag4 S3	25.04.13.1			
Date:	25-Apr-2013	Sheet 1 of	1		
File:	D:\M&W\...\Pro-Drag4_S3_2.sch	Drawn By:	M&W		

M & W IGNITIONS

Performance & Quality since 1996

FOR DRAG RACING USE ONLY

CAUTION!
HIGH VOLTAGE

DISCONNECT POWER BEFORE
WORKING ON UNIT

NOTE!

TRIPLE ROTOR MAZDA

Two 4 channel cdi ignition systems will be required for this installation.

Wire three of the ignition circuits on one cdi ignition for the leading ignition coils and three circuits of the other cdi ignition for the trailing ignition coils.

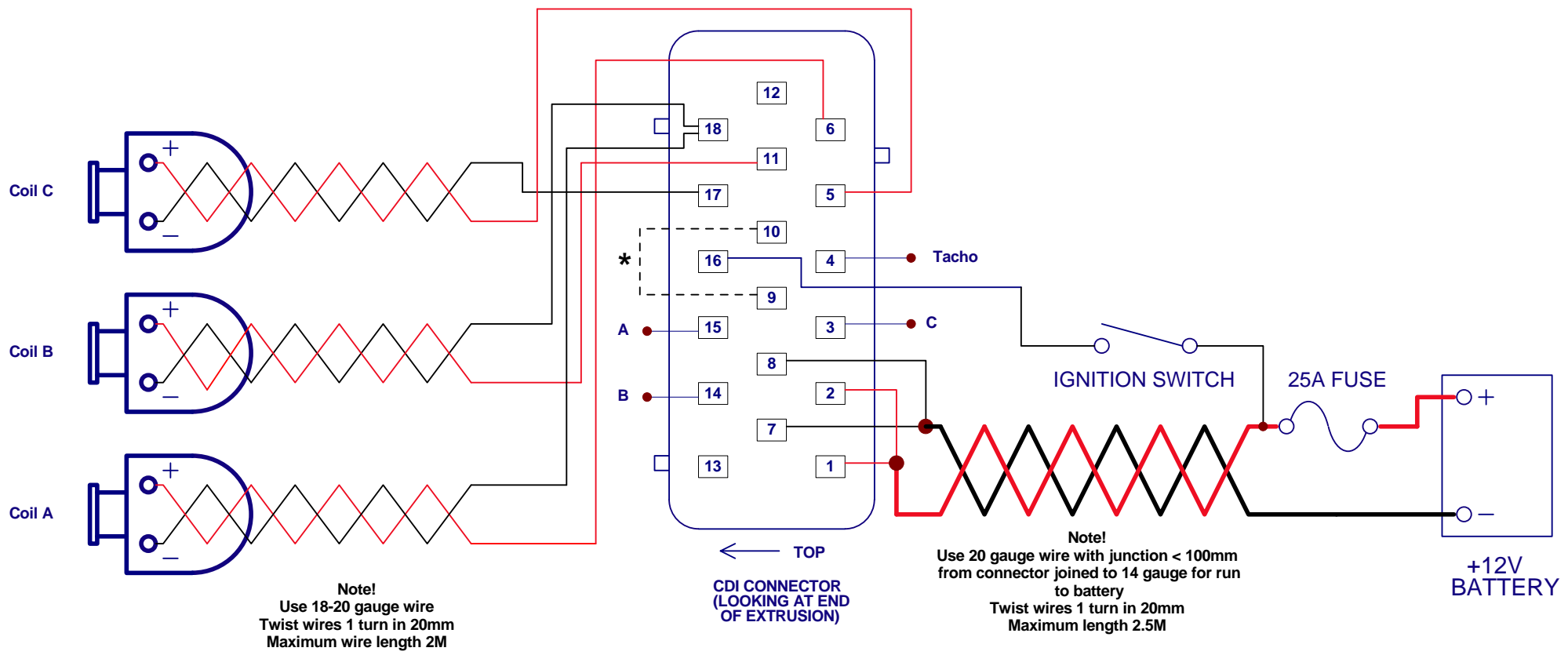

Note!
Use 18-20 gauge wire
Twist wires 1 turn in 20mm
Maximum wire length 2M

*** See installation instructions for trigger edge selection**

Title			TRIPLE ROTOR MAZDA		
Size	Number		Revision		
A4		Pro-Drag4 S3		25.04.13.1	
Date:	25-Apr-2013		Sheet 1 of 1		
File:	D:\M&W\...\Pro-Drag4_S3_4.sch		Drawn By:	M&W	

M & W IGNITIONS

Performance & Quality since 1996

**CAUTION!
HIGH VOLTAGE**

**DISCONNECT POWER BEFORE
WORKING ON UNIT**

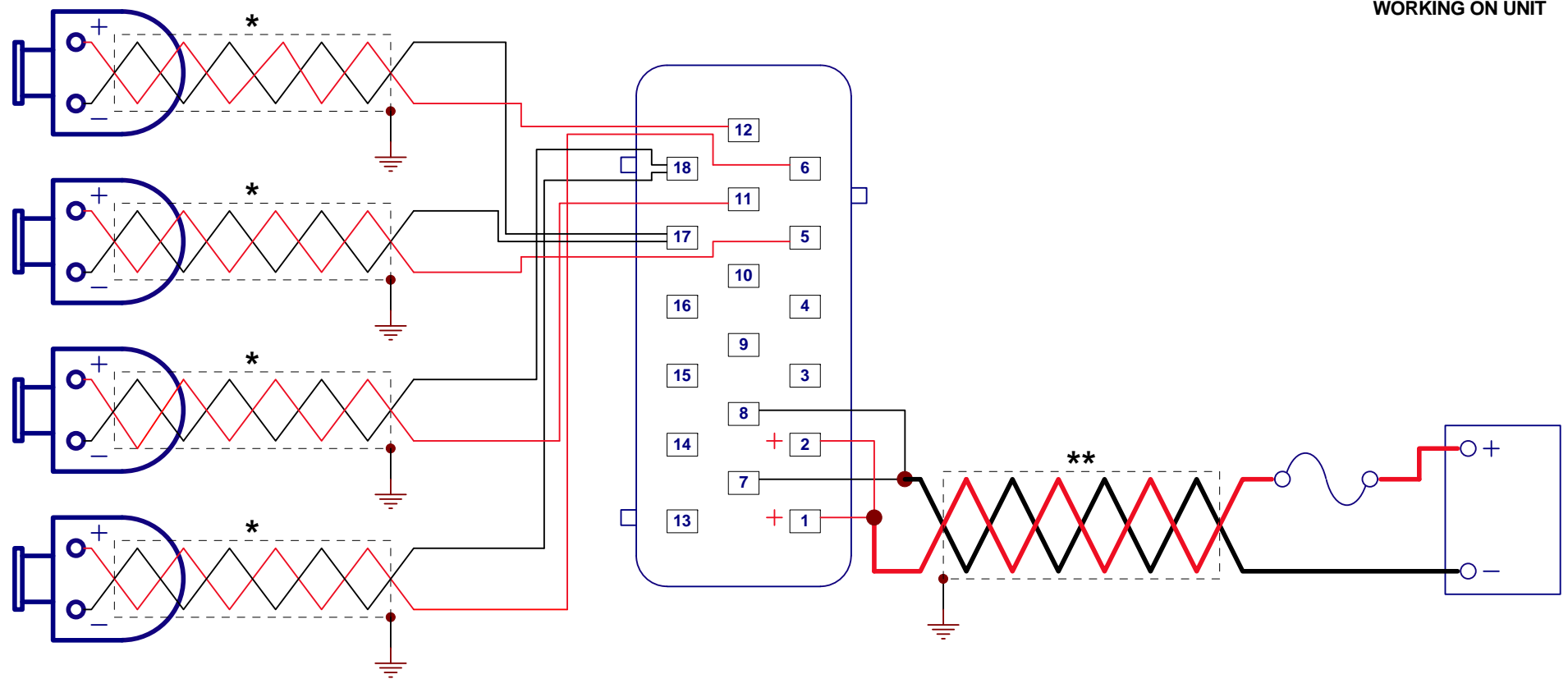

- * Use twisted shielded cable grounded at one end only
- ** Shielded power cables required for Australian EMC compliance

Title			SHIELDING & EMC COMPLIANCE		
Size	Number	Revision			
A4	Pro-Drag4 500 S3	25.04.13.1			
Date:	25-Apr-2013	Sheet 1 of	1		
File:	D:\M&W\...\EMC.sch	Drawn By:	M&W		