



# **Pro-Drag6**

## **6 CHANNEL 160/250mJ CAPACITOR DISCHARGE IGNITION**

**Applicable  
S/No's 39xxxx**

### **CONTENTS:**

2. Installation notes
6. Ignition coil information
7. Connections and specifications
8. 6 coil reciprocating & rotary Box-A
9. 6 coil reciprocating & rotary Box-B
10. Mounting dimensions

**ADDITIONAL INSTALLATION RESOURCES  
AVAILABLE FROM WEBSITE**

# INSTALLATION NOTES

(Pro-Drag 250mJ Series 3 systems)

## MOUNTING

Do not mount the unit where it will be exposed to water or other liquids, ensure the bottom condensation slots are unobstructed and oriented to permit gravity drain. Select a location away from intense heat and if required provide a source of cooling air.

**Failure to use supplied rubber mounts will void warranty!**

## IGNITION LEADS

Do not use plain metal wire or carbon core ignition leads.

Use spiral wound inductively suppressed metal conductor ignition leads such as those available from Magnecor [www.magnecor.com](http://www.magnecor.com).

## SPARK PLUGS

The use of use non resistor spark plugs (where possible) will greatly enhance ignition performance.

In some installations the use of resistor spark plugs may be unavoidable. In these cases ensure they are not damaged by testing internal resistance value as part of regular maintenance. Open circuit or high resistance may cause failure of spark plug wires, ignition coils and CDI.

The use surface discharge or semi surface discharge spark plugs are limited to naturally aspirated engines.

**Keep spark plug gap  $\leq 0.020$ " (0.5mm) for COP coils and  $\leq 0.025$ " (0.65mm) for non COP coil high boost applications.**

## INSULATION PRECAUTIONS

Degrease spark plug insulators, coil/plug boots and installation tooling to prevent arc tracking or insulation breakdown.

Use (supplied) dielectric grease on spark plug insulators and coil/plug boots to increase insulation properties and ease

installation/removal (use of dielectric grease in main connector may also reduce water ingress).

## POWER SUPPLY

Do not use voltage boosters or connect through a PDM.

**If wired to a power source shared with the ECU or its sensors erratic operation may be experienced!**

If running a total loss electrical system install a 16V or 18V battery to ensure supply voltage is maintained above 13V.

## WIRING

**Wire ignition system directly to battery!**

If required wire length exceeds recommendations use paired battery cable for power and ground to make up distance. Do not rely on vehicle chassis to provide ground path.

M&W CDI systems are designed to open circuit the external fuse under conditions of over voltage or reverse polarity. Faults such as loose battery terminals, poor wiring or defective alternator/regulator may also cause this to occur.

Use twisted shielded pair wire similar to M27500 for all power/coil connections. Keep coil wires one continuous length and do not fit an intermediate connector.

Main connector pins are designed to be roll crimped. Squeeze crimping or soldering will cause distortion possibly resulting in misfiring or incorrect CDI operation.

Common coil negative wires must be joined at/inside the connector (connector pin will correctly crimp a max of 2 \* 20ga wires).

**Keep coil primary wires well separated from HT leads, coil HV outlet, coil body and any input wiring!**

## TRIGGERING

Single box - channels may be triggered in any sequence, twin box – firing sequence must alternate between boxes (except rotary).

250mJ Pro-Drag systems include a trigger edge selection input which defaults to falling edge ignition when not connected. To select rising edge ignition install a jumper wire between inputs 'Trigger

Edge' and 'Edge Ground' pins. Where the ECU contains an inbuilt igniter it may be necessary to use rising edge ignition.

**If CDI trigger edge and ECU ignition edge do not match timing will be erratic and vary with RPM!**

### POWER LEVEL SWITCH

To reduce ignition energy under low load conditions some M&W 250mJ units include an (active low) power level switch.

Do not manually activate this feature. Install an adjustable 'Hobbs' style manifold pressure switch or use a programmable output from the ECU to ground the input when engine comes under load.

### TUNING

**CDI systems are 'edge triggered' and not effected by dwell settings!**

M&W CDI systems may reduce combustion delay and percentage misfire requiring a reduction in ignition timing. These changes to combustion characteristics may also require alterations to fuel flow. Set ECU ignition delay to zero and tune engine as required.

**Always re tune both fuel and timing curves after installing CDI ignition.**

### TACHO OUTPUT

The tacho output provides a 50% duty cycle square wave signal approximately 1V below battery supply voltage. This will work with most aftermarket digital tacho's however earlier types and those designed for coil negative triggering may require a tacho adaptor.

### LED INDICATOR

After applying power to switch wire the LED will illuminate, after approximately 1 second it will extinguish then flash briefly with each consecutive trigger event.

A repeated double flash of the LED may indicate a possible faulty ignition coil, faulty wiring, low supply voltage or damage to the CDI.

## TESTING

The CDI may be tested by momentarily grounding the trigger inputs causing the LED to flash and corresponding ignition coil to spark.

**Do not conduct this test without grounded spark plugs installed!**

## SAFETY

Application of power to ignition system in combination with an inadvertent ignition event from ECU (powered up/down or engine rotation) may cause damage to ignition coils, CDI or nearby personnel.

1. Install grounded metal studs in engine bay and transfer spark plug ends of HT leads to these between race events or at least when working on engine.
2. Install aircraft style guarded toggle switch in the CDI ignition switch wire circuit and disable it at all times except when running the engine.

**Due to extreme energy and voltage levels developed by M&W ignition systems it is strongly recommended caution be taken to ensure personnel safety and prevent ignition component damage!**

## INSTALLATION PRECAUTIONS

Care must be taken due to the propensity for HV flashovers and insulation breakdown caused by CDI ignitions unique characteristics.

**The main cause of CDI damage is conduction of high voltage to coil primary wiring.**

It is essential to fully read and understand these instructions and have a comprehensive knowledge of automotive electrical systems before commencing installation.

For further information may be found under the support tab on our website.

# IGNITION COILS

(Pro-Drag 250mJ systems)

## COIL SELECTION

For ultimate ignition energy use coils specifically designed for CDI use such as the M&W #COI006. Ignition coils primarily designed for inductive ignition will significantly limit CDI output.

## COP COILS

COP (coil on plug) coils were not designed for the energy levels and voltage potentials developed by M&W Pro-Drag systems.

**Use COP coils at your own risk!**

## FERRITE CDI COILS

Ferrite core cdi coils provide a lightweight solution for direct fire applications and give high secondary current however they are not be suitable for all applications due to their extremely short arc duration. The high level of EMI emitted by these coils may require additional shielding to prevent electrical interference.

## **CAUTION!**

Use resistive spark plugs with all COP coils!

Keep spark plug gap  $\leq 0.020"$  (0.5mm) for COP coils and  $\leq 0.025"$  (0.65mm) for non COP coil high boost applications.

DO NOT wire ferrite coils in parallel pairs!

DO NOT use 'Prufex' brand outboard motor coils or AEM pencil coils under any circumstances!

**IGNITION COIL DAMAGE WILL OCCUR IF  
OPERATED WITH AN EXCESSIVE SPARK GAP**

# M & W IGNITIONS

Performance & Quality

**CAUTION!  
HIGH VOLTAGE**



**DISCONNECT POWER BEFORE  
WORKING ON UNIT**

**VIEWED FROM BACK OF CONNECTOR**



## SPECIFICATIONS

Operating voltage	13V --> 18V DC
Polarity	Negative ground
Startup voltage	>= 6V
Maximum supply current	15A (per box)
Power off current	< 700uA
Maximum ignition frequency	2,000Hz (combined)
Energy limit	1,400Hz (combined)
Coil primary voltage	400V/500V
Spark energy	160mJ/250mJ
Trigger:	
Current	10mA
Edge	Adjustable
Voltage rising	>= 3.2V
Voltage falling	<= 1.6V
Tacho output:	
Voltage	Supply - 1.2V
Output current	100mA
Shape	Square wave
Operating temperature	<= 105°C
Dimensions	122L * 110W * 40H
Weight	800gm

1 +12V (Battery)	7 Ground (Battery)	13 Power level
2 +12V (Battery)	8 Ground (Battery)	14 Triggers C & D
3 Triggers E & F	9 Trigger edge	15 Triggers A & B
4 Tacho	10 Signal ground	16 Ignition switch
5 Coils E & F +	11 Coils C & D +	17 Coils E & F -
6 Coils A & B +	12	18 Coils A/C & B/D -

Title			<b>PRO-DRAG6 160/250mJ</b>		
Size	Number			Revision	
A4	<b>(C) M&amp;W Ignitions</b>		<b>25.07.17.1</b>		
Date:	26-Jul-2017	Sheet 1 of 1			
File:	D:\M&W\...\Pro-Drage6 250 S3 1 SW.sch	Drawn By:		WAG	

### Wire Specifications

#### POWER SUPPLY:

Use 14ga wire from battery bifurcated into 20ga wire <= 100mm from connector. Junction is best achieved using a Solistrand or similar butt splice / barrel crimp. Maximum recommended wire length is 2M

#### IGNITION COILS:

Use 20ga wire from cdi to coils and keep as one continuous length. Maximum recommended wire length is 2M

**Read installation guide for important wiring details!**

# M & W IGNITIONS

Performance & Quality

**CAUTION!  
HIGH VOLTAGE**



**DISCONNECT POWER BEFORE  
WORKING ON UNIT**

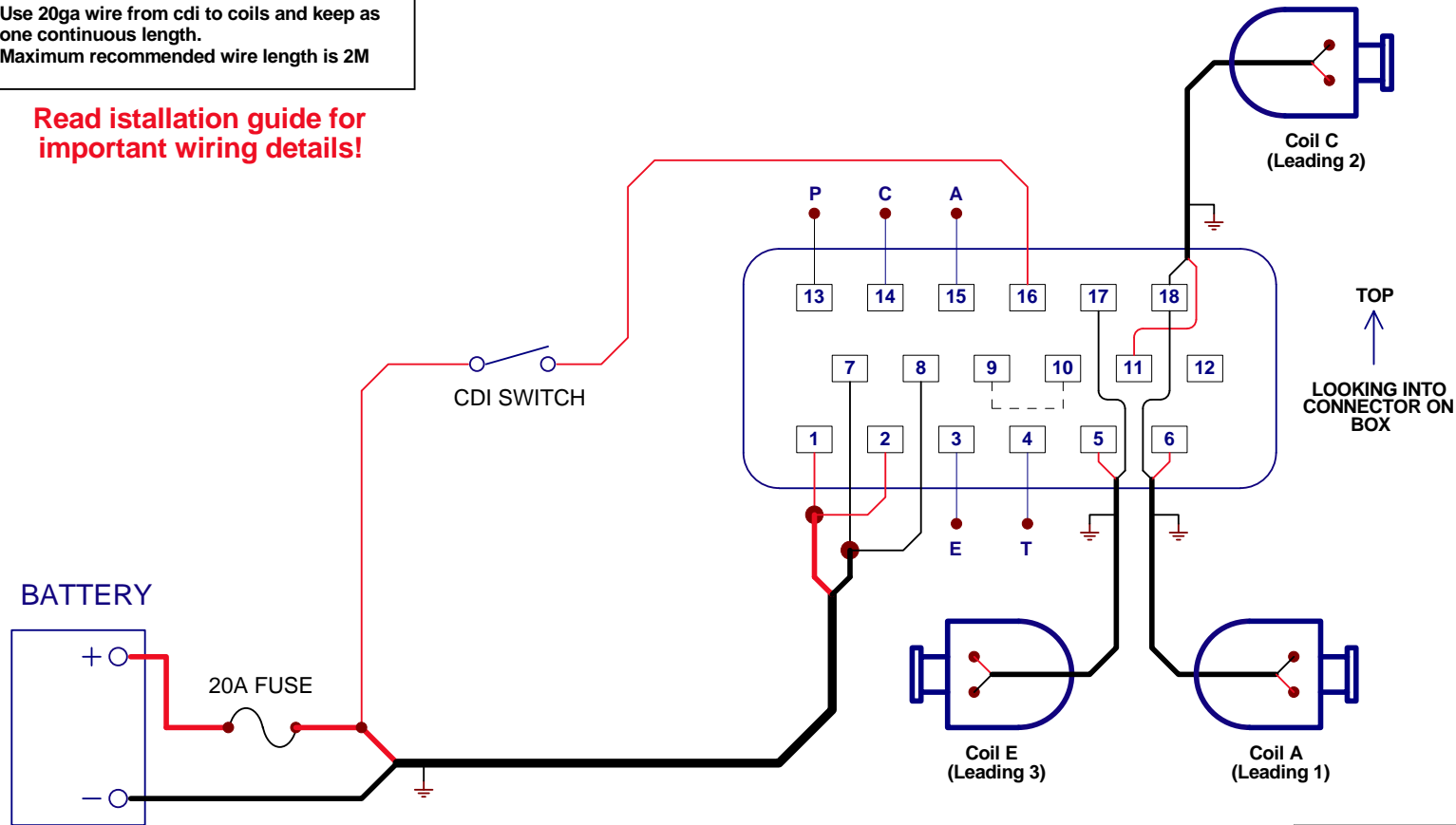

Title			<b>PRO-DRAG6 160/250mJ (Box-A)</b>
Size	Number	Revision	
A4	<b>(C) M&amp;W Ignitions</b>	<b>25.07.17.1</b>	
Date:	25-Jul-2017	Sheet 1 of 1	
File:	D:\M&W\...\Pro14 S3 2.sch	Drawn By:	WAG



### Wire Specifications

**POWER SUPPLY:**

Use 14ga wire from battery bifurcated into 20ga wire <= 100mm from connector. Junction is best achieved using a Solistrand or similar butt splice / barrel crimp. Maximum recommended wire length is 2M

**IGNITION COILS:**

Use 20ga wire from cdi to coils and keep as one continuous length. Maximum recommended wire length is 2M

**Read installation guide for important wiring details!**

# M & W IGNITIONS

Performance & Quality

**CAUTION!  
HIGH VOLTAGE**



**DISCONNECT POWER BEFORE  
WORKING ON UNIT**

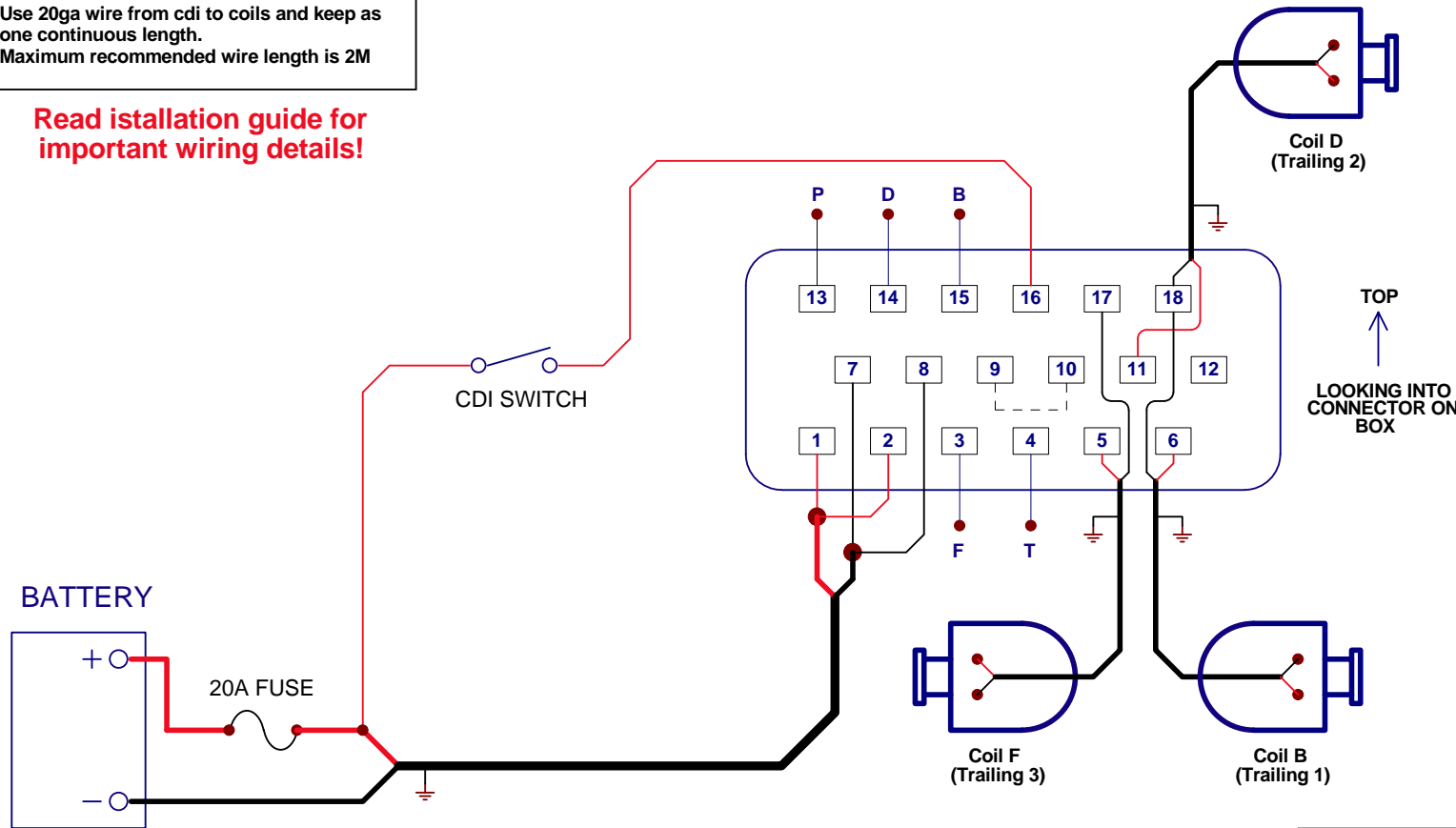

Title			<b>PRO-DRAG6 160/250mJ (Box-B)</b>
Size	Number	Revision	
A4	<b>(C) M&amp;W Ignitions</b>	<b>25.07.17.1</b>	
Date:	25-Jul-2017	Sheet 1 of	1
File:	D:\M&W\...\Pro-Drag6 250 S3 2B SW.sch	Drawn By:	WAG

# M & W IGNITIONS

Performance & Quality

**CAUTION!**  
**HIGH VOLTAGE**



**DISCONNECT POWER BEFORE  
WORKING ON UNIT**

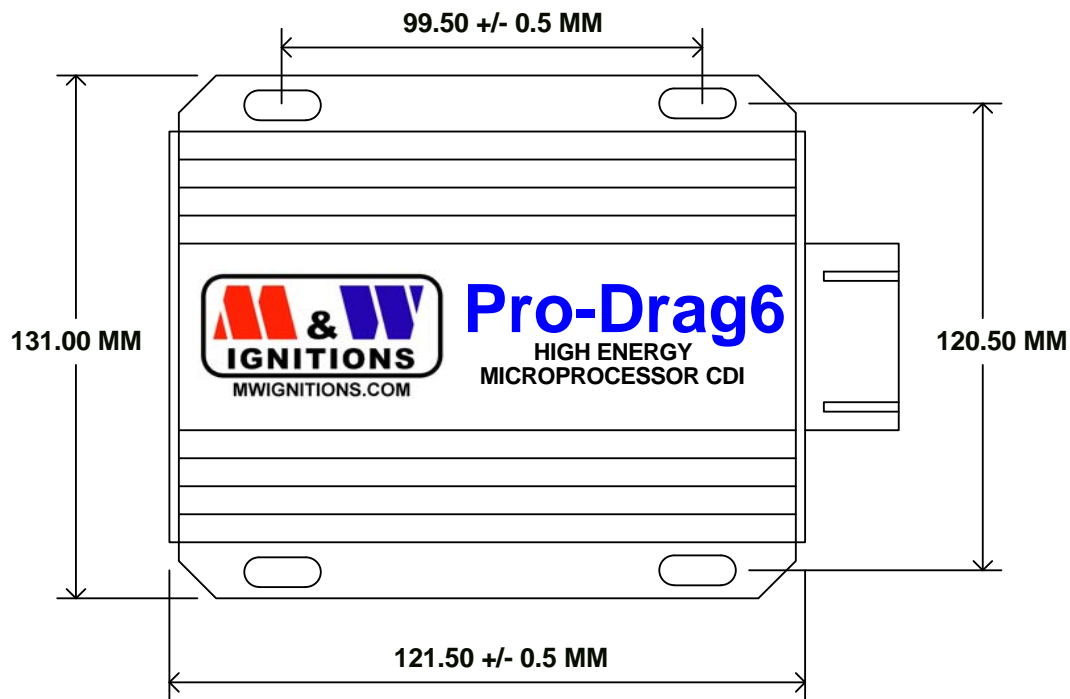

Slot dimensions - 5mm \* 10mm

Title		<b>MOUNTING DIMENSIONS</b>	
Size	Number	Revision	
A4	<b>(C) M&amp;W Ignitions</b>	<b>25.07.17.1</b>	
Date:	25-Jul-2017	Sheet 1 of 1	
File:	D:\M&W\...\Pro-Drag6 250 S3 mounting dimensions.dwg		