



WWW.MWIGNITIONS.COM

Pro-Drag6

6 CHANNEL 500mJ CAPACITOR DISCHARGE IGNITION

PLEASE REPORT ANY OMISSIONS OR
ERRORS TO SALES@MWIGNITIONS.COM

CONTENTS:

1. Installation notes
2. Ignition coil information
3. Mounting dimensions
4. Connections and specifications
5. 6 channel direct fire ignition
6. Mazda triple rotor ignition

CAUTION

**THIS WIRING DIAGRAM IS
APPLICABLE ONLY TO IGNITION
SYSTEMS WITH THE SERIAL
NUMBER PREFIX STARTING**

45xxxx

**USE OF INCORRECT DIAGRAM
WILL VOID WARRANTY AND
MAY DAMAGE UNIT**

INSTALLATION NOTES

MOUNTING

Do not mount the unit where it will be exposed to water or other liquids and ensure the bottom drain slots are unobstructed. Select a location away from excessive heat and provide a cooling air supply if required. Use soft rubber (40 duro) mounts on all four corners to isolate from strong vibration.

IGNITION LEADS & SPARKPLUGS

Straight metal wire ignition leads radiate electrical interference which may cause erratic operation of nearby electronic devices including the CDI. Carbon suppressed ignition leads are not capable of conducting the CDI energy without becoming damaged.

For best performance use spiral wound inductively suppressed metal core ignition leads such as those produced by Magnecor[®]. Where possible use non resistor spark plugs to reduce energy loss.

WIRING & POWER SUPPLY

FAILURE TO INSTALL THE RECOMMENDED SIZE FUSE WILL VOID WARRANTY

Trigger input & coil output numbers indicate ignition sequence not cylinder number.

250mJ and larger Pro-Drag CDI systems must not be operated below 13V.

Voltage boosters may limit CDI operation and ignition performance will not increase when operated above 13.8V

Connect the CDI directly to the battery with the recommended gauge wire. All coil negative wires must be joined at or in the connector.

Use twisted pair wire for all power and coil connections. To comply with Australian EMC 'C Tick' standards and for ultimate noise suppression use shielded twisted pair wire.

TRIGGERING

All M&W CDI systems defaults to falling edge ignition, to select rising edge ignition connect the 'Trigger Edge' pin to the 'Signal Ground' pin. Where the ecu contains an in built igniter or there is an igniter between the ECU and CDI it may be necessary to select rising edge ignition. **The trigger edge on the CDI must be set the same as that in the ECU!**

For Autronic® multiplex ignitions set the ecu for –VE Edge (Pulse).

DWELL

M&W CDI systems are 'edge' triggered which means they are not affected by changes in dwell time. If your ecu requires a dwell time be set then use something small such as 0.5-1mS.

LED INDICATOR

After initially applying power to the CDI the LED will illuminate for 1 second then extinguish. The LED will then flash briefly with each consecutive trigger event received.

A repeated double flash of the LED indicates a possible faulty ignition coil, faulty wiring, low supply voltage or damage to the CDI.

TESTING

The CDI may be tested by momentarily grounding the inputs (with the exception of Reluctor trigger cdi's), this will cause the corresponding ignition coil to spark. Do not conduct this test without a grounded sparkplug installed. A comprehensive test procedure document may be found on our web site

http://www.mwignitions.com/pg_data_sheets.php

CAUTION

TO PREVENT IGNITION COIL DAMAGE DO NOT
FIRE THE CDI WITH AN EXCESSIVE SPARK GAP!

CHECK IGNITION TIMING AFTER COMPLETION

IGNITION COILS

COIL SELECTION

Most inductive ignition coils will work satisfactorily with CDI systems however for ultimate ignition energy use a coil specifically designed for CDI applications.

COP COILS

COP (coil on plug) coils with inbuilt drivers are not suitable for use with CDI ignition. COP coils designed for inductive ignition may overheat when used in cdi applications and some contain an internal blocking diode in the secondary winding which must be taken into account during wiring.

FERRITE CDI COILS

Ferrite core cdi coils provide a light weight solution for direct fire applications and give high secondary current however they may not be suitable for all applications due to their very short arc duration. The high level of EMI emitted by these coils may require additional wire shielding to prevent electrical interference with the ECU.

Note! Ferrite CDI coils are for direct fire ignition only. For high performance distributor applications use a coil similar to a Crane[®] PS92 or MSD[®] HVC2.

COIL POLARITY

All diagrams are shown for cdi style coils, for correct operation with inductive ignition coils they should be wired with their primary connections reversed to maintain correct spark plug polarity.

CAUTION!

IGNITION COIL DAMAGE MAY OCCUR IF OPERATED WITH AN EXCESSIVE SPARK GAP.

M & W IGNITIONS

(C)1996 - 2008 M&W IGNITIONS

NOT FOR STREET USE!

**CAUTION!
HIGH VOLTAGE**



**DISCONNECT POWER BEFORE
WORKING ON UNIT**

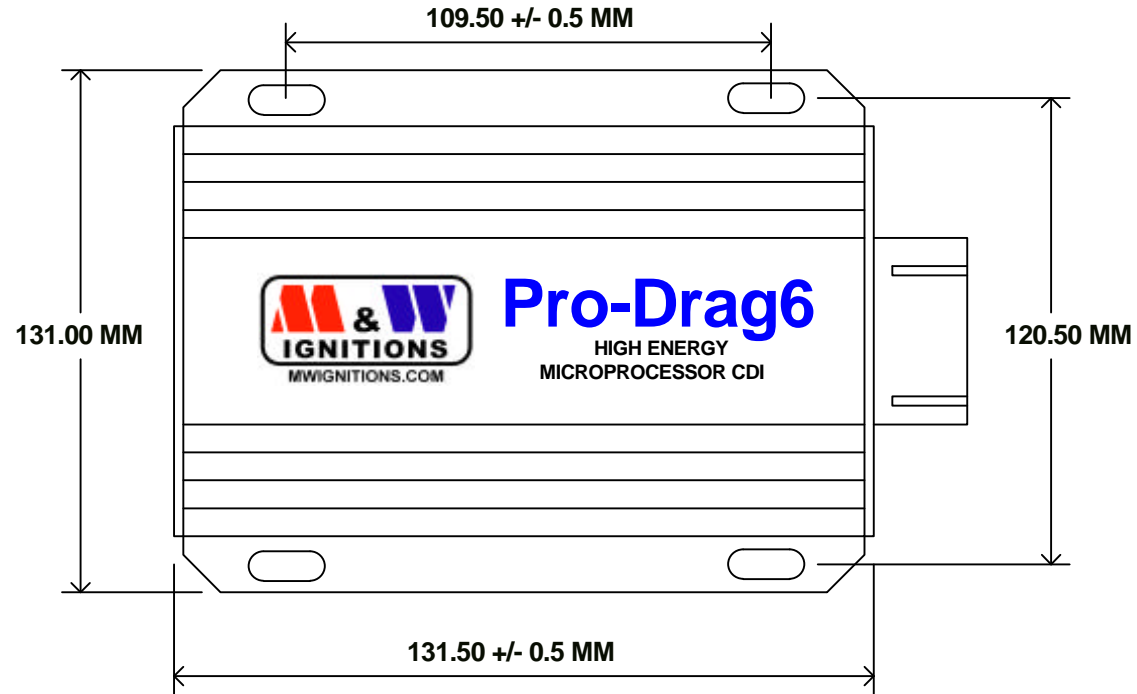

Slot dimensions - 5mm * 10mm

Title		MOUNTING DIMENSIONS	
Size	Number	Revision	
A4	Pro-Drag6 500 S3	1.0	
Date:	12-Dec-2008	Sheet 1 of 1	
File:	E:\M&W\Pro-Drag6_S3_500_Mounting Dimensions.sch		

NOT FOR STREET USE!



DISCONNECT POWER BEFORE WORKING ON UNIT

VIEWED FROM BACK OF CONNECTOR



FAILURE TO INSTALL FUSES WILL VOID WARRANTY

POWER SWITCH SELECTION

For best operation we recommend that Pin 9 on both boxes be connected in parallel to an output from the ECU which can be mapped to ground this pin when the engine boost exceeds 10-15 psi or as required.
Alternatively connect Pin 9 on both boxes in parallel to one side of a normally open 'Hobbs' style manifold pressure switch. Connect the other side of the switch to ground and adjust for operation around 10-15 psig.

KEEP ALL INPUTS WELL SEPARATED FROM COIL OUTPUTS

1 +12V (Battery)	7 Ground (Battery)	13
2 +12V (Battery)	8 Ground (Battery)	14 Triggers 3 & 4
3 Triggers 5 & 6	9 Power switch	15 Triggers 1 & 2
4 Tacho	10 Signal ground	16 Ignition control
5 Coils 5 & 6 +	11 Coils 3 & 4 +	17 Coils 5 & 6 -
6 Coils 1 & 2 +	12	18 Coils 1/3 & 2/4 -

SPECIFICATIONS

Supply voltage = 13.8V DC negative ground
 Operating voltage = 13V to +15V
 Maximum supply current = 20A (per unit)
 Power off current < 700uA
 Maximum ignition frequency = 750 Hz combined
 Coil primary voltage = 500V
 Spark energy = 280/500millijoules
 Trigger = 10mA adjustable edge
 Tacho = 12V, 25mA square wave
 Maximum allowable case temperature = 105°C
 Dimensions = 112L * 110W * 40H
 Weight = 900gm (each)

Title			PRO-DRAG6 280MJ/500MJ		
Size	Number	Revision			
A4	SERIES 3	1.3			
Date:	6-Sep-2011	Sheet 1 of 1			
File:	D:\M&W\Pro-Drag6_S3_500_1.sch	Drawn By: M&W			

FIRING ORDER MUST ALTERNATE BETWEEN BOXES



CAUTION!
HIGH VOLTAGE

- * Numbers indicate firing order not cylinder number
- ** Shielded cables required for Australian EMC compliance

NOT FOR STREET USE!

DISCONNECT POWER BEFORE WORKING ON UNIT

Note!
Use 20 gauge wire with junction < 100mm from connector
Join to 14 gauge for run to battery
Twist wires 1 turn in 20mm
Maximum length 2.5M

FAILURE TO INSTALL FUSES WILL VOID WARRANTY

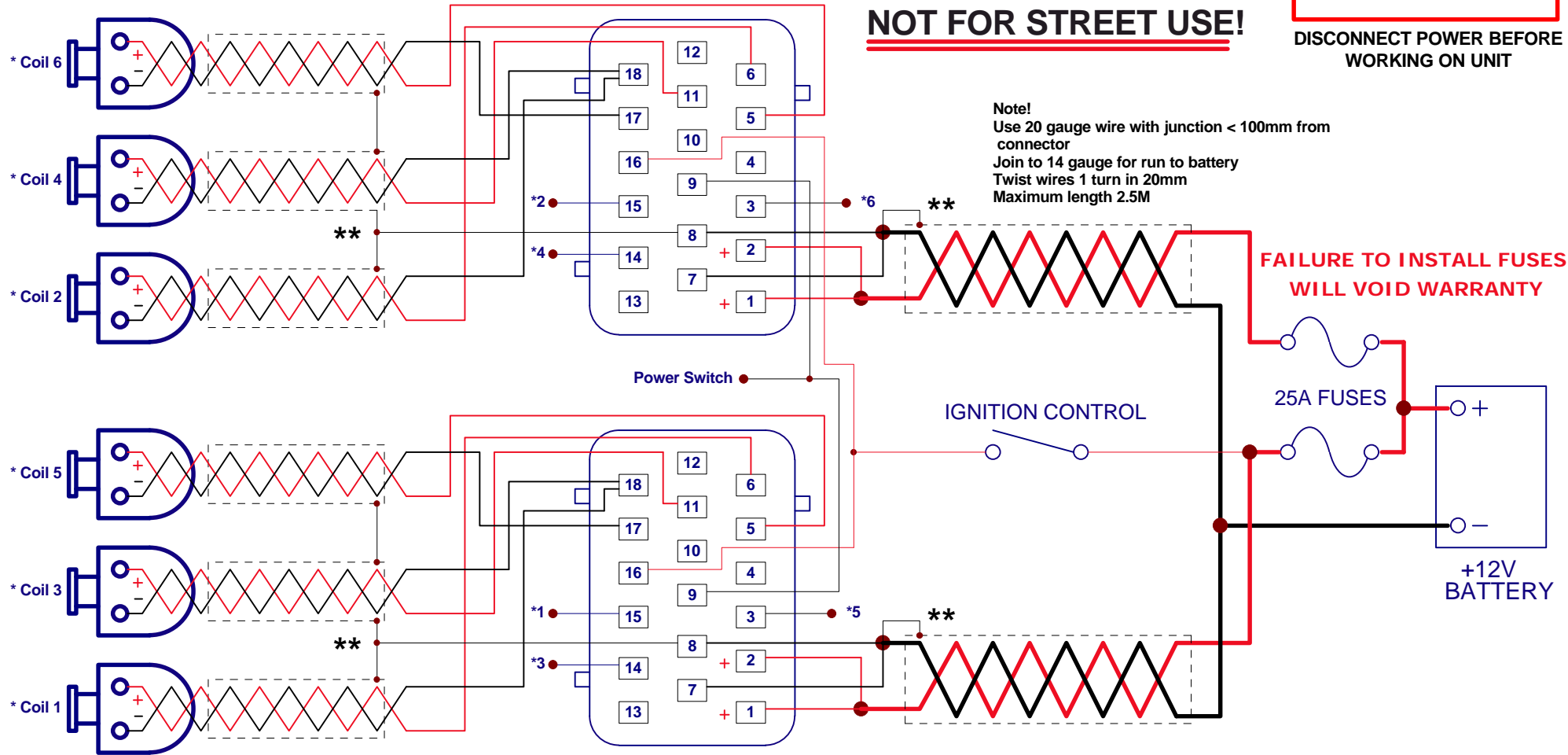

Note!
Use 18-20 gauge wire
Twist wires 1 turn in 20mm
Maximum wire length 2M

← TOP
CDI CONNECTOR
(LOOKING AT END OF EXTRUSION)

Title			6 CHANNEL SEQUENTIAL IGNITION		
Size	Number	Revision			
A4	Pro-Drag6 500 S3	1.2			
Date:	12-Dec-2008	Sheet 1 of	1		
File:	E:\M&W\Pro-Drag6_S3_500_2.sch	Drawn By:	M&W		

**FIRING ORDER MUST
ALTERNATE BETWEEN BOXES**

**** Shielded cables required for Australian EMC compliance**



**DISCONNECT POWER BEFORE
WORKING ON UNIT**

NOT FOR STREET USE!

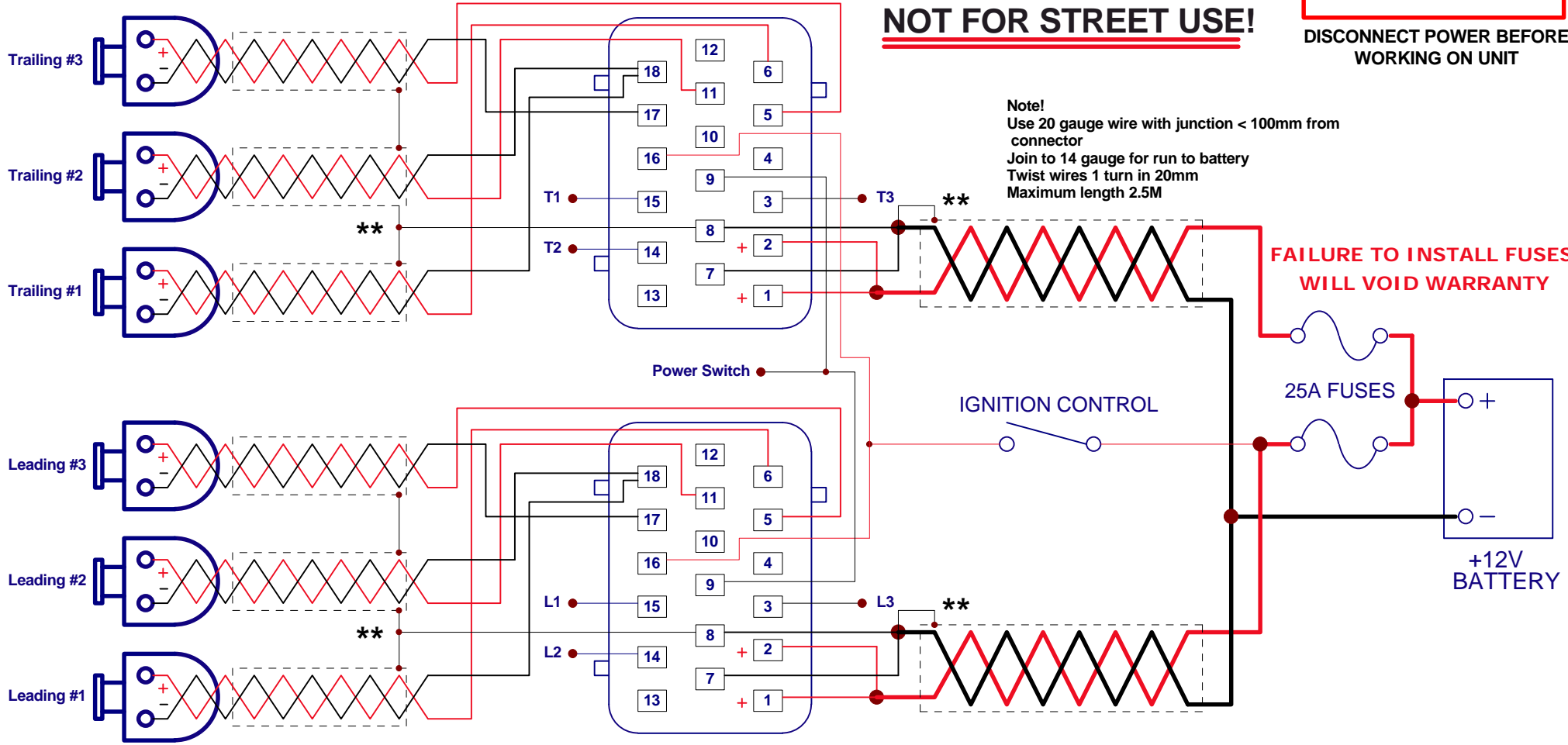

Note!
Use 18-20 gauge wire
Twist wires 1 turn in 20mm
Maximum wire length 2M

← **TOP**
**CDI CONNECTOR
(LOOKING AT END
OF EXTRUSION)**

Title			MAZDA TRIPE ROTOR IGNITION		
Size	Number	Revision			
A4	Pro-Drag6 500 S3	1.2			
Date:	12-Dec-2008	Sheet 1 of	1		
File:	E:\M&W\Pro-Drag6_S3_500_3.sch	Drawn By:	M&W		

M & W IGNITIONS

Performance & Quality since 1996

CAUTION!
HIGH VOLTAGE



DISCONNECT POWER BEFORE WORKING ON UNIT

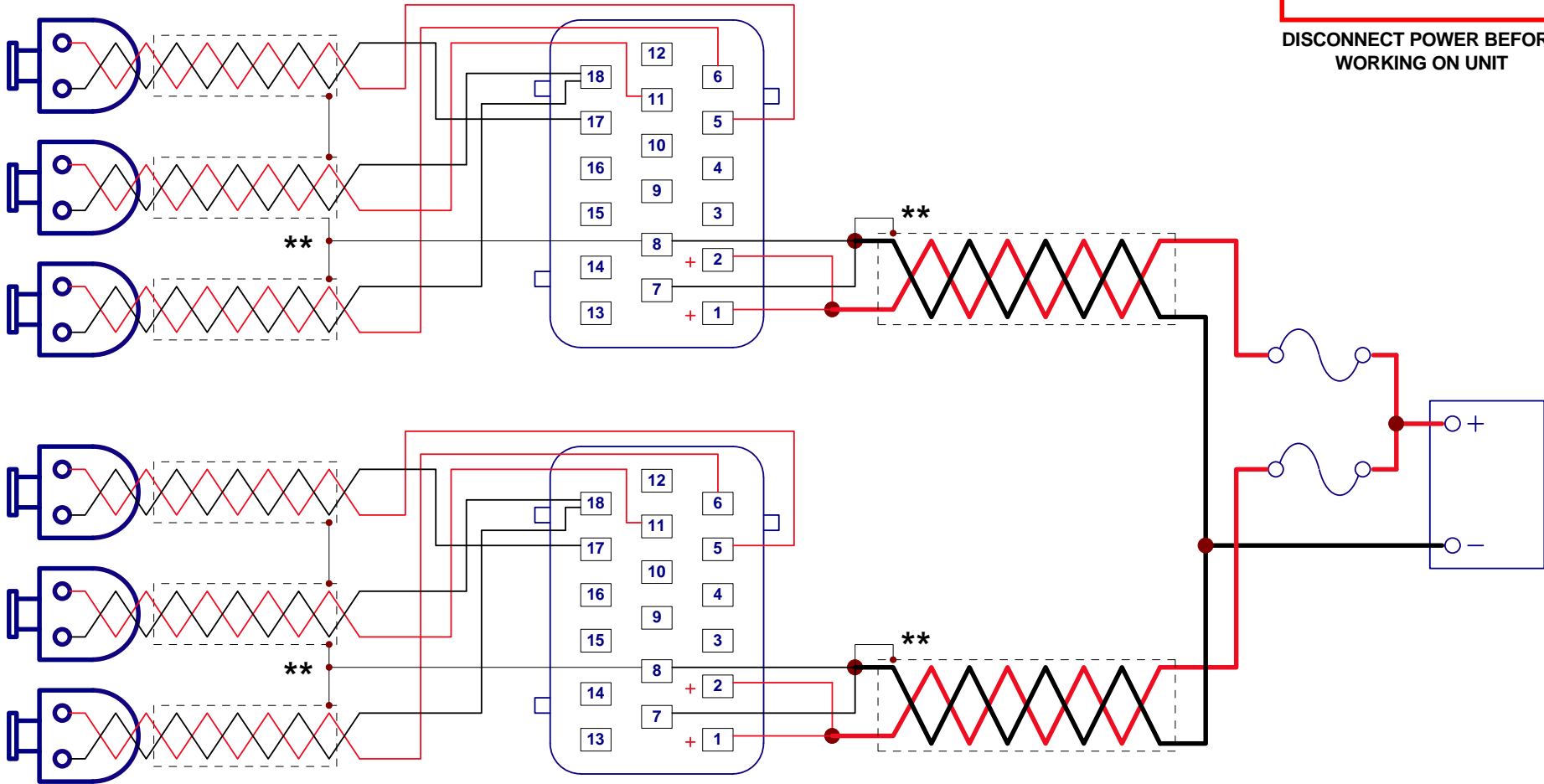

**** Shielded cables required for Australian EMC compliance**

Title			AUSTRALIAN EMC COMPLIANCE		
Size	Number	Revision			
A4	Pro-Drag6 S3	1.0			
Date:	13-Sep-2010	Sheet 1 of 1			
File:	D:\M&W\EMC.sch	Drawn By: M&W			