



# **PRO-14 EVO**

## **DIRECT FIRE CAPACITOR DISCHARGE IGNITION**

PLEASE REPORT ANY ERRORS  
SALES@MWIGNITIONS.COM

### **CONTENTS:**

1. Installation notes
2. Ignition coil information
3. Mounting dimensions
4. Connections and specifications
5. Wiring schematic
6. Australian EMC requirements

# **CAUTION**

**THIS WIRING DIAGRAM IS  
APPLICABLE ONLY TO IGNITION  
SYSTEMS WITH THE SERIAL  
NUMBER PREFIX STARTING**

**62xxxx**

**USE OF INCORRECT DIAGRAM  
WILL VOID WARRANTY AND  
MAY DAMAGE UNIT**

# INSTALLATION NOTES

## MOUNTING

Do not mount the unit where it will be exposed to water or other liquids and ensure the bottom drain slots are unobstructed. Select a location away from excessive heat and provide a cooling air supply if required. Use soft rubber (40 duro) mounts on all four corners to isolate from strong vibration.

## IGNITION LEADS & SPARKPLUGS

Straight metal wire ignition leads radiate electrical interference which may cause erratic operation of nearby electronic devices including the CDI. Carbon suppressed ignition leads are not capable of conducting the CDI energy without becoming damaged.

For best performance use spiral wound inductively suppressed metal core ignition leads such as those produced by Magnecor<sup>®</sup>. Where possible use non resistor spark plugs to reduce energy loss.

## WIRING & POWER SUPPLY

**FAILURE TO INSTALL THE RECOMMENDED SIZE FUSE WILL VOID WARRANTY**

Trigger input & coil output numbers indicate ignition sequence not cylinder number.

250mJ and larger Pro-Drag CDI systems must not be operated below 13V.

Voltage boosters may limit CDI operation and ignition performance will not increase when operated above 13.8V

Connect the CDI directly to the battery with the recommended gauge wire. All coil negative wires must be joined at or in the connector.

Use twisted pair wire for all power and coil connections. To comply with Australian EMC 'C Tick' standards and for ultimate noise suppression use shielded twisted pair wire.

## TRIGGERING

Both the M&W Pro-14 Evo and Pro-Drag4 Evo CDI systems are designed to de-multiplex the two existing ignition channels and provide true direct fire ignition from the factory computer. This will effectively double the per sparkplug ignition energy and simultaneously halving ignition coil heat loading.

## LED INDICATOR

When the CDI is initially powered up the LED will illuminate for approximately 1 second to indicate normal boot sequence then extinguish. For the first couple of firing cycles the LED will not illuminate, once engine synchronisation is achieved and the unit is operating in direct fire mode the LED will flash briefly for each ignition event.

A repeated double flash of the LED indicates a possible faulty ignition coil, faulty wiring, low supply voltage or damage to the CDI.

## TESTING

The CDI may be tested by momentarily grounding the inputs. This will cause the corresponding ignition coil pair to spark. The unit will not operate in direct fire mode when using this method. Do not conduct this test without a grounded sparkplug installed.

## CAUTION

TO PREVENT IGNITION COIL DAMAGE DO NOT  
FIRE THE CDI WITHOUT A GROUNDED SPARK  
PLUG AND DO NOT MAKE THE SPARK JUMP AN  
EXCESSIVE GAP

CHECK IGNITION TIMING AFTER COMPLETION

# IGNITION COILS

## COIL SELECTION

Most inductive ignition coils will work satisfactorily with CDI systems however for ultimate ignition energy use a coil specifically designed for CDI applications.

## COP COILS

COP (coil on plug) coils with inbuilt drivers are not suitable for use with CDI ignition. COP coils designed for inductive ignition may overheat when used in cdi applications and some contain an internal blocking diode in the secondary winding which must be taken into account during wiring.

## FERRITE CDI COILS

Ferrite core cdi coils provide a light weight solution for direct fire applications and give high secondary current however they may not be suitable for all applications due to their very short arc duration. The high level of EMI emitted by these coils may require additional wire shielding to prevent electrical interference with the ECU.

**Note!** Ferrite CDI coils are for direct fire ignition only. For high performance distributor applications use a coil similar to a Crane<sup>®</sup> PS92 or MSD<sup>®</sup> HVC2.

## COIL POLARITY

**All diagrams are shown for cdi style coils, for correct operation with inductive ignition coils they should be wired with their primary connections reversed to maintain correct spark plug polarity.**

**CAUTION!**

**IGNITION COIL DAMAGE MAY OCCUR IF OPERATED WITH AN EXCESSIVE SPARK GAP.**

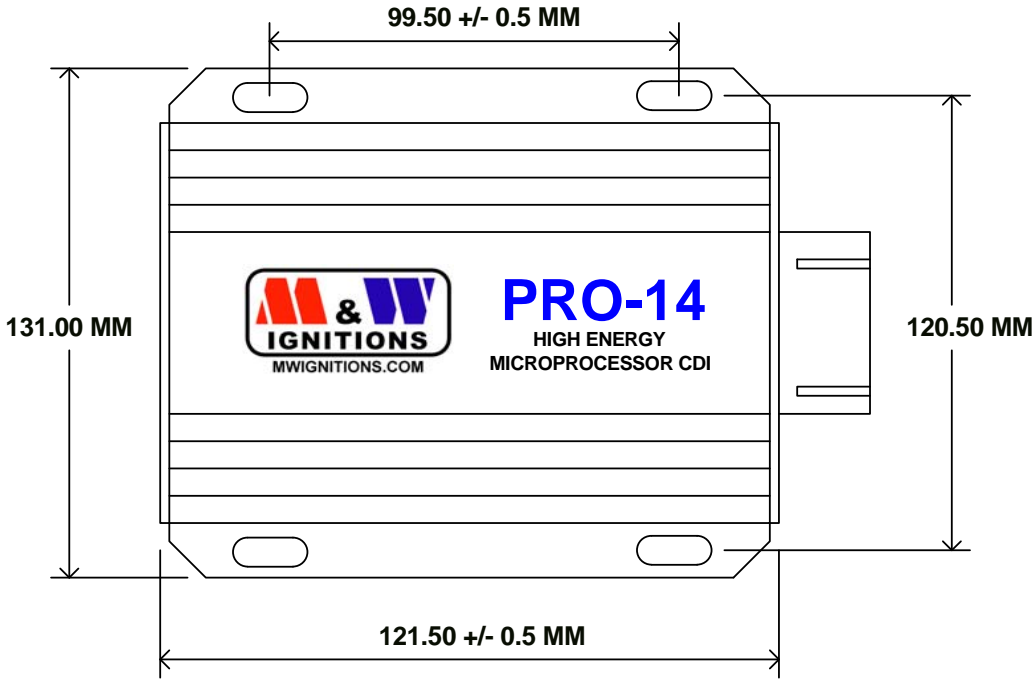

Slot dimensions - 5mm \* 10mm

Title		<b>MOUNTING DIMENSIONS</b>	
Size	Number	Revision	
A4	<b>PRO-14 EVO S3</b>	1.0	
Date:	7-Oct-2010	Sheet 1 of 1	
File:	D:\M&W\Pro-14 Evo mounting dimensions	Drawn By:	M&W



DISCONNECT POWER BEFORE WORKING ON UNIT

VIEWED FROM BACK OF CONNECTOR



**KEEP ALL INPUTS WELL SEPARATED FROM COIL OUTPUTS**

1 +12V (Battery)	7 Ground (Battery)	13 Power Level
2 +12V (Battery)	8 Ground (Battery)	14 Trigger 2/3
3 Cam Signal	9	15 Trigger 1/4
4 Tacho	10 Signal ground	16 Ignition switch
5 Coil 3 +	11 Coil 2 +	17 Coil 3 & 4 -
6 Coil 1 +	12 Coil 4 +	18 Coil 1 & 2 -

**POWER LEVEL**

Leave power level switch (Pin 13) disconnected for 105mJ mode or connected to Pin 10 for 150mJ mode.

Some ignition coils will be damaged if driven continuously in high power mode therefore it is strongly recommended that the high power setting be activated by a mechanical pressure switch or spare output from the ECU (when available) only as required.

**SPECIFICATIONS**

Supply voltage = 13.8V DC negative ground  
 Operating voltage = +6.5V to +18V  
 Maximum supply current = 6.0A  
 Power off current < 700uA  
 Maximum ignition frequency = 1,000 Hz  
 Coil primary voltage = 460V/550V  
 Spark energy = 115/150 millijoules per coil  
 Trigger = 10mA falling edge  
 Tacho = 12V, 25mA 50% duty cycle square wave  
 Maximum allowable case temperature = 105°C  
 Dimensions = 122L \* 110W \* 40H  
 Weight = 570gm

Title <b>MITSUBISHI EVO DIRECT FIRE IGNITION</b>		
Size A4	Number <b>PRO-14 EVO S3</b>	Revision <b>1.0</b>
Date: 7-Oct-2010	Sheet 1 of 1	Drawn By: M&W
File: D:\M&W\Pro-14_Evo_S3_1.sch		

# M & W IGNITIONS

Performance & Quality since 1996

**CAUTION!**  
**HIGH VOLTAGE**



**DISCONNECT POWER BEFORE  
WORKING ON UNIT**

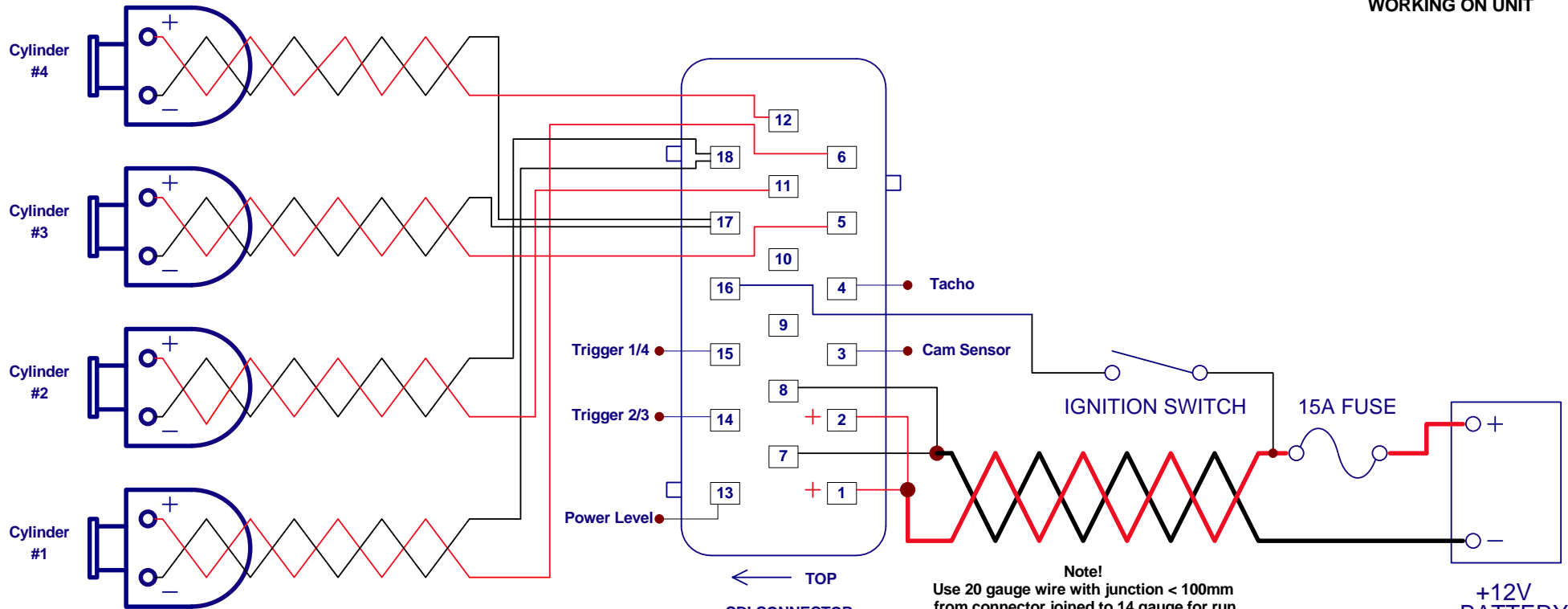

**Note!**  
Use 18-20 gauge wire  
Twist wires 1 turn in 20mm  
Maximum wire length 2M

**Note!**  
Use 20 gauge wire with junction < 100mm  
from connector joined to 14 gauge for run  
to battery  
Twist wires 1 turn in 20mm  
Maximum length 2.5M

Title		<b>EVO DIRECT FIRE IGNITION</b>	
Size	Number	Revision	
A4	<b>PRO-EVO S3</b>	1.0	
Date:	1-Oct-2010	Sheet 1 of 1	
File:	D:\M&W\Pro-Evo_S3_2.sch	Drawn By:	M&W

# M & W IGNITIONS

Performance & Quality since 1996

**CAUTION!**  
**HIGH VOLTAGE**



**DISCONNECT POWER BEFORE  
WORKING ON UNIT**

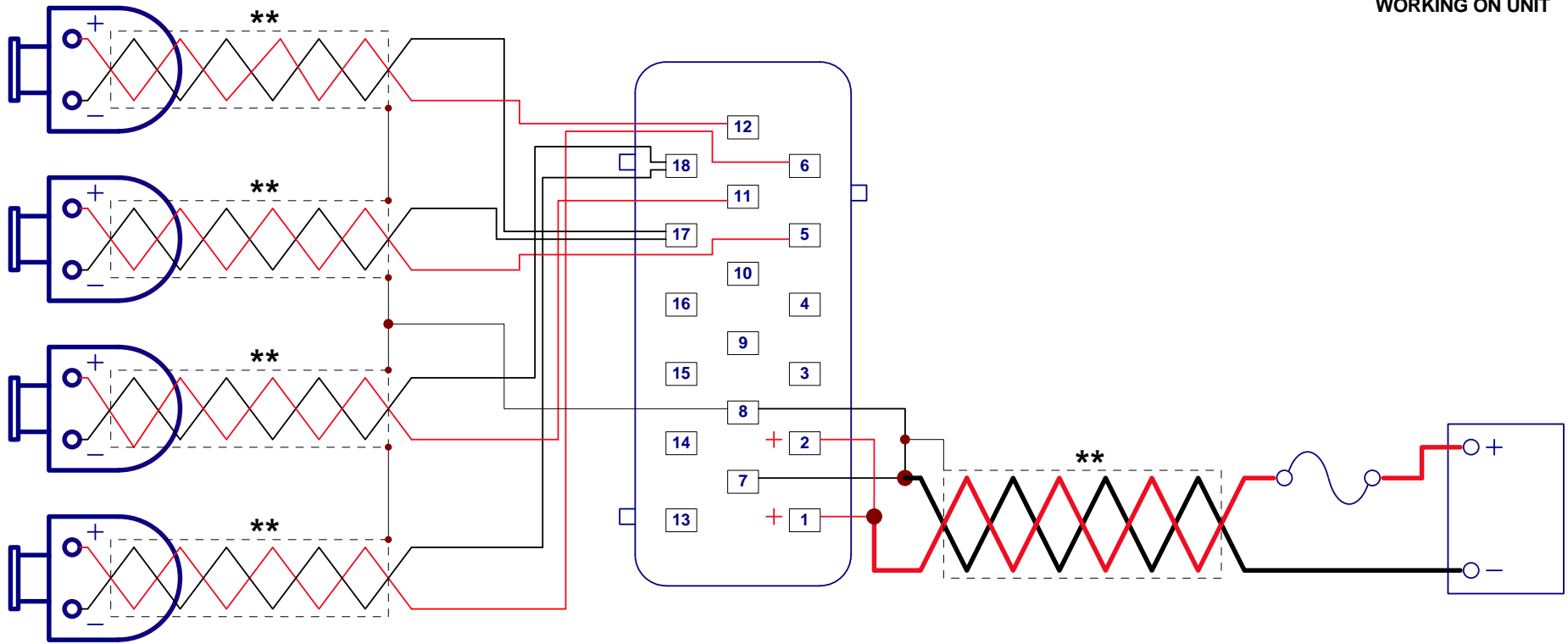

**\*\* Shielded cables required for ultimate noise reduction and Australian EMC compliance**

Title			AUSTRALIAN EMC REQUIREMENTS		
Size	Number	Revision			
A4	PRO-14 EVO S3	1.0			
Date:	7-Oct-2010	Sheet 1 of 1			
File:	D:\M&W\Diagrams\Pro-14 Evo\EMC.sch	Drawn By:		M&W	