



# **PRO-16d**

## **6 CHANNEL**

(MoTeC<sup>®</sup> IGNITION EXPANDER)

## **CAPACITOR DISCHARGE**

## **IGNITION**

**SALES@MWIGNITIONS.COM**  
Ph. +61-2-9668-8481

### **CONTENTS:**

2. Caution
3. Installation notes
7. Ignition coil information
8. Mounting dimensions
9. Connections and specifications
10. 6 channel MoTeC<sup>®</sup> IEX ignition
11. Shielding & EMC compliance

**CHECK WEBSITE FOR UPDATED INSTRUCTIONS  
& ADDITIONAL INFORMATION**

# **CAUTION**

**THIS WIRING DIAGRAM IS  
APPLICABLE ONLY TO IGNITION  
SYSTEMS WITH SERIAL NUMBER  
PREFIX STARTING**

**54xxxx**

**USE OF INCORRECT DIAGRAM WILL  
VOID WARRANTY AND MAY DAMAGE  
UNIT**

**THE INSTALLATION OF HIGH ENERGY IGNITION  
SYSTEMS MAY REQUIRE ADVANCED  
KNOWLEDGE AND SKILLS.**

**IMPROPER INSTALLATION OR OPERATION OF  
THIS UNIT COULD CAUSE DAMAGE TO IGNITION  
SYSTEM AND IGNITION COIL**

# INSTALLATION NOTES

(MoTeC® IEX compatible street systems only)

## MOUNTING

Do not mount the unit where it will be exposed to water or other liquids, ensure the bottom condensation slots are unobstructed and oriented to permit gravity drain. Select a location away from intense heat and if required provide a source of cooling air to remove internally generated heat.

**Failure to use supplied rubber mounts will void warranty!**

## IGNITION LEADS

Do not use plain metal wire or carbon core ignition leads.

Use spiral wound inductively suppressed metal core ignition leads such as those available from Magnecor [www.magnecor.com](http://www.magnecor.com).

## SPARK PLUGS

The use of use non resistor spark plugs (where possible) will greatly enhance ignition performance.

In some installations the use of resistor spark plugs may be unavoidable. In these cases ensure they are not damaged by measuring internal resistance value as part of regular maintenance and monitor for changes. Open circuit or high resistance may cause failure of spark plug wires, ignition coils and CDI.

Surface discharge and semi surface discharge spark plugs are designed for use with CDI ignition however be aware they have a large non-adjustable spark gap suitable only for naturally aspirated or low boost applications.

## INSULATION PRECAUTIONS

Degrease spark plug insulators and coil/plug boots after handling to prevent tracking or insulation breakdown.

Use (supplied) dielectric grease on spark plug insulators and coil/plug boots to increase insulation properties and ease

installation/removal. Use of dielectric grease in main connector may reduce water ingress.

## WIRING & POWER SUPPLY

M&W CDI systems are designed to blow the external fuse under conditions of over voltage or reverse polarity. Faults such as loose battery terminals, poor wiring or defective alternator/regulator may also cause for this to occur. Fitting a larger capacity fuse won't disable this feature, will void warranty and may cause irreparable damage to unit. **Only fit the recommended size fuse!**

Main connector pins are designed to be roll crimped. Squeeze crimping or soldering will cause distortion resulting in misfiring or incorrect CDI operation.

Wire ignition system directly to battery. If required wire length exceeds recommendations use small paired battery cable (power and ground) to make up distance. Do not rely on vehicle chassis to provide ground path. If connected to a high impedance supply shared with ECU or its sensors erratic operation will be experienced.

Do not use voltage boosters as most can't provide the instantaneous current required for correct CDI operation.

When using a total loss electrical system install either a 16V or 18V battery to ensure adequate supply voltage. If using extended voltage batteries isolate them during charging to prevent excessive voltage reaching the CDI and ECU.

Use twisted pair wire for all power and coil connections. For improved noise suppression and to comply with Australian EMC 'C Tick' standards use twisted shielded pair wire for coils. Twisted pair wire must be used for power/ground. Keep coil wires one continuous length from CDI and do not fit any intermediate connectors into harness. All coil negative wires must be joined at or in the cdi connector. Keep coil primary (CDI) wires away from HT leads, coil HV outlet and coil body to prevent a flashover occurring.

## TRIGGERING

M&W IEX trigger ignition systems are designed to directly replicate the function of a Motec Ignition Expander unit. Due to the complex nature of ECU configuration it is best to consult your Motec distributor for assistance with this setup.

Trigger input & coil output numbers (letters) indicate CDI ignition sequence not cylinder number.

## MODE SELECTION

When using M&W IEX cdi's with Motec M4/M48 ecu's join the Mode and Signal Ground terminals in the main connector. See applicable diagram for correct terminal numbers.

## POWER LEVEL SWITCH

Some M&W Pro street systems are provided with a (active low) power level switch. Do not manually activate this feature or operate continuously as this will significantly increase spark plug wear and system current draw. Activate by grounding input through either a 'Hobbs' style manifold pressure switch or programmable output from the ECU when elevated energy levels are required.

## TUNING

CDI systems are 'edge triggered' and not effected by dwell settings.

M&W CDI systems may reduce combustion delay and percentage misfire requiring a reduction in ignition timing. The resulting changes in combustion characteristics may also require alterations to fuel flow. Set ECU ignition delay to zero and tune engine as required.

**Always re tune both fuel and timing curves after installing CDI ignition.**

## TACHO OUTPUT

The tacho output provides a 50% duty cycle square wave signal at battery supply voltage. This signal will work with most aftermarket digital tacho's however those designed for coil negative triggering may not read accurately. In this case use a tacho adaptor such as the M&W TAC002.

## LED INDICATOR

After applying power to switch wire the LED will illuminate for 1 second and extinguish. The LED will then flash briefly with each consecutive trigger event received (it may be necessary to view the LED directly on axis).

A repeated double flash of the LED may indicate a possible faulty ignition coil, faulty wiring, low supply voltage or damage to the CDI.

## TESTING

It is not possible to manually trigger MoTeC<sup>®</sup> IEX compatible CDI systems therefore a self test mode has been built into firmware. By grounding this input before powering unit it will sequentially fire all outputs and flash the LED in sync. To exit test mode disconnect power from unit and remove test ground connection.

**Do not conduct this test without grounded spark plugs installed!**

## INSTALLATION PRECAUTIONS

**The main cause of CDI damage is conduction of high voltage to coil primary wiring.**

Care must be taken due to the propensity for HV flashovers and insulation breakdown caused by CDI ignitions unique characteristics.

It is important to fully read and understand these instructions and have a good knowledge of automotive electrical systems before commencing installation.

For further instructions and cdi information check out the support tab and Q&A section on our web site  
<http://www.mwignitions.com>

# IGNITION COILS

(Pro-Street systems only)

## COIL SELECTION

Most inductive ignition coils will work reasonably well with CDI systems however for ultimate ignition energy and efficiency use a coil specifically designed for CDI use.

## COP COILS

COP (coil on plug) coils with inbuilt drivers are not suitable for use with CDI ignition. COP coils designed for inductive ignition may contain a blocking diode in the secondary winding which must be considered during wiring (see coil polarity note below). **Use resistive spark plugs with all COP coils. Keep plug gap < 0.025" (0.6mm) to prevent coil damage. DO NOT use AEM pencil coils under any circumstances!**

## FERRITE CDI COILS

Ferrite core cdi coils provide a lightweight solution for direct fire applications and give high secondary current however they may not be suitable for all applications due to their extremely short arc duration. The high level of EMI emitted by these coils may also require additional shielding to prevent electrical interference with the ECU or CDI. **Do not use ferrite coils in parallel wired pairs!**

## COIL POLARITY

All diagrams are shown for cdi style coils. For correct operation with inductive ignition coils wire the primary connections in reverse to maintain correct spark plug polarity.

**CAUTION!**

**IGNITION COIL DAMAGE MAY OCCUR IF  
OPERATED WITH AN EXCESSIVE SPARK GAP**

**CAUTION!**  
**HIGH VOLTAGE**



**DISCONNECT POWER BEFORE  
WORKING ON UNIT**

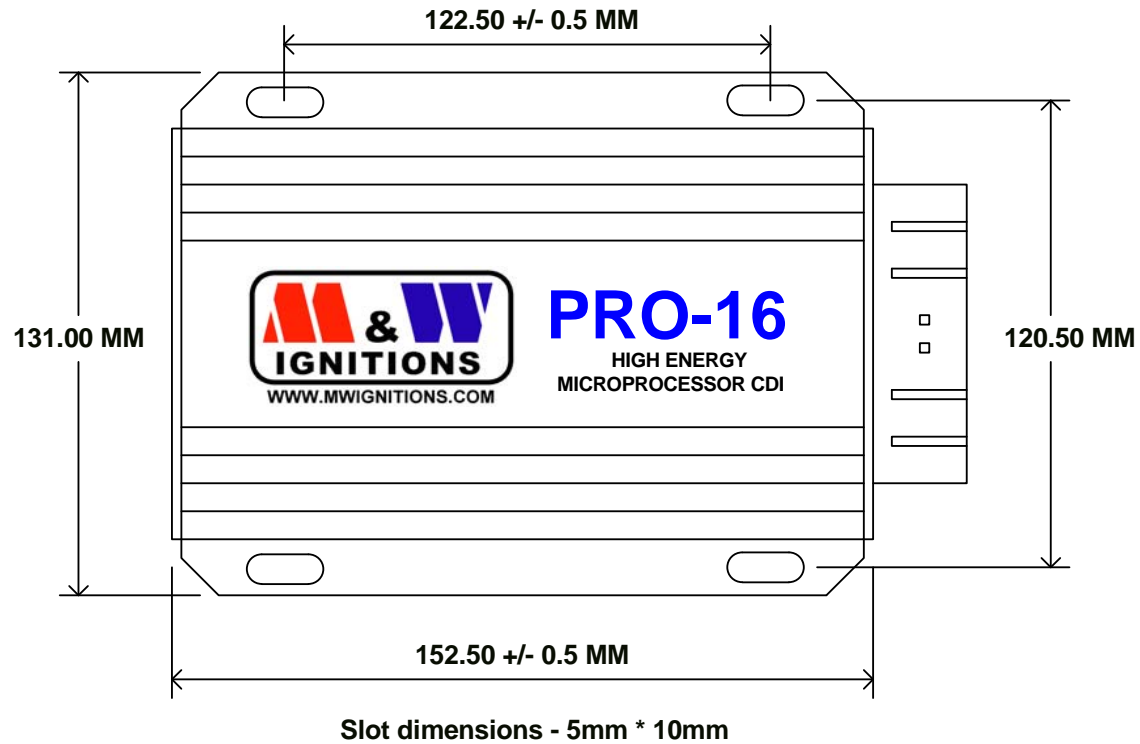

Title			<b>PRO-16d MOUNTING DIMENSIONS</b>
Size	Number	Revision	
A4	<b>(C) M&amp;W Ignitions</b>	07.06.13.1	
Date:	7-Jun-2013	Sheet 1 of	1
File:	D:\M&W\...\Mounting dimensions.sch	Drawn By:	M&W



**CAUTION!**  
**HIGH VOLTAGE**



DISCONNECT POWER BEFORE  
WORKING ON UNIT



VIEWED FROM BACK OF CONNECTOR



**KEEP ALL INPUTS WELL SEPARATED FROM COIL OUTPUTS**

1	+12V (Battery)	13	Ground (Battery)	25	
2	+12V (Battery)	14	Ground (Battery)	26	Ignition switch
3		15	IEX input	27	
4		16		28	
5	Mode	17	Signal ground	29	Self test
6	Tacho	18	Shield	30	
7		19		31	
8		20		32	
9		21		33	
10	Coil 5** +	22	Coil 5 & 6 -	34	Coil 6** +
11	Coil 3** +	23	Coil 3 & 4 -	35	Coil 4** +
12	Coil 1** +	24	Coil 1 & 2 -	36	Coil 2** +

**\*\* FIRING SEQUENCE NOT CYLINDER NUMBER**

**SPECIFICATIONS**

Operating voltage = 13V - 18V DC negative ground  
 Startup voltage = +6V  
 Maximum supply current = 7.0A  
 Power off current < 700uA  
 Maximum ignition frequency = 1,200Hz  
 Maximum energy limit = 700 Hz  
 Coil primary voltage = 480V  
 Spark energy = 115 millijoules @ 700Hz  
 Trigger = Motec IEX input  
 Tacho = 12V 100mA symmetric square wave  
 Maximum case temperature = 105°C  
 Dimensions = 152L \* 110W \* 40H  
 Weight = 740gm

Title			PRO-16d 6 CHANNEL MOTEC IEX CDI
Size	Number	Revision	
A4	(C) M&W Ignitions	25.06.13.1	
Date:	25-Jun-2013	Sheet 1 of	1
File:	D:\M&W\...\Pro16d_S3_1.sch	Drawn By:	M&W

**CAUTION!**  
**HIGH VOLTAGE**



DISCONNECT POWER BEFORE WORKING ON UNIT

# M & W IGNITIONS

Performance & Quality since 1996

Note!  
Use 20 gauge wire  
Twist wires 1 turn in 20mm  
Maximum wire length 2M

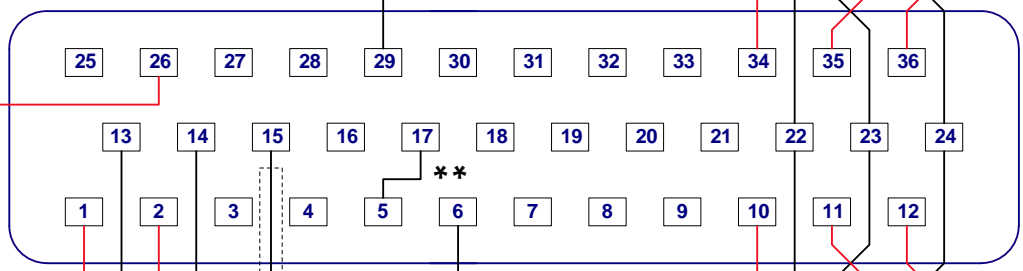
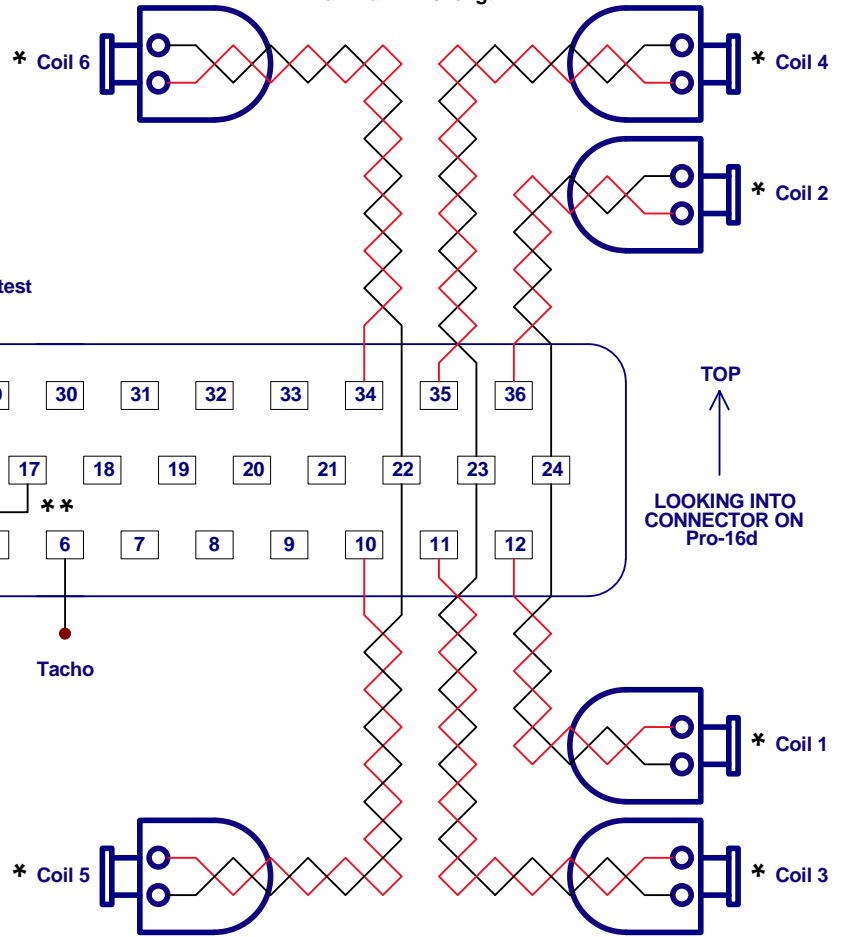

TOP  
↑  
LOOKING INTO CONNECTOR ON Pro-16d

IGNITION SWITCH

+12V BATTERY  
15A FUSE

Note!  
Use 20 gauge wire with junction < 100mm from connector joined to 14 gauge for run to battery  
Twist wires 1 turn in 20mm  
Maximum length 2.5M

IEX Input  
ECU Input 0 Volt  
Shield cable!

Tacho

- \* Firing order not cylinder number
- \*\* Join terminals 5 & 17 for M4 / M48 mode

Title			PRO-16d 6 CHANNEL MOTEC IEX CDI		
Size	Number		(C) M&W Ignitions		Revision
A4					07.06.13.1
Date:	7-Jun-2013		Sheet 1 of 1		
File:	D:\M&W\...\Pro16d_S3_2.sch		Drawn By: M&W		

**CAUTION!**  
**HIGH VOLTAGE**



DISCONNECT POWER BEFORE  
WORKING ON UNIT

# M & W IGNITIONS

Performance & Quality since 1996

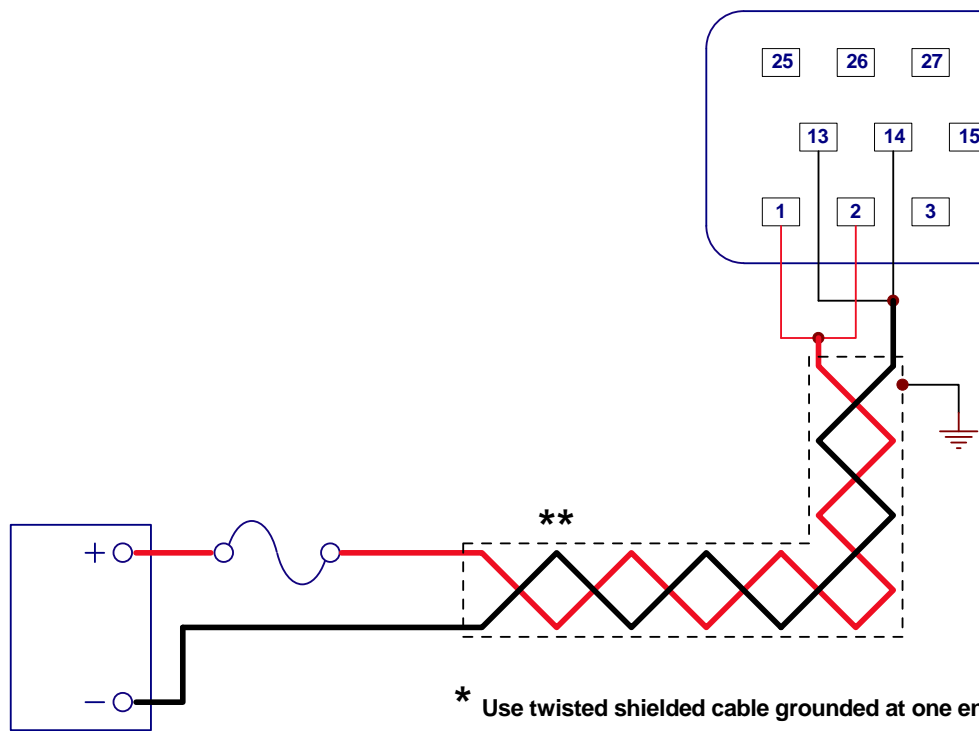
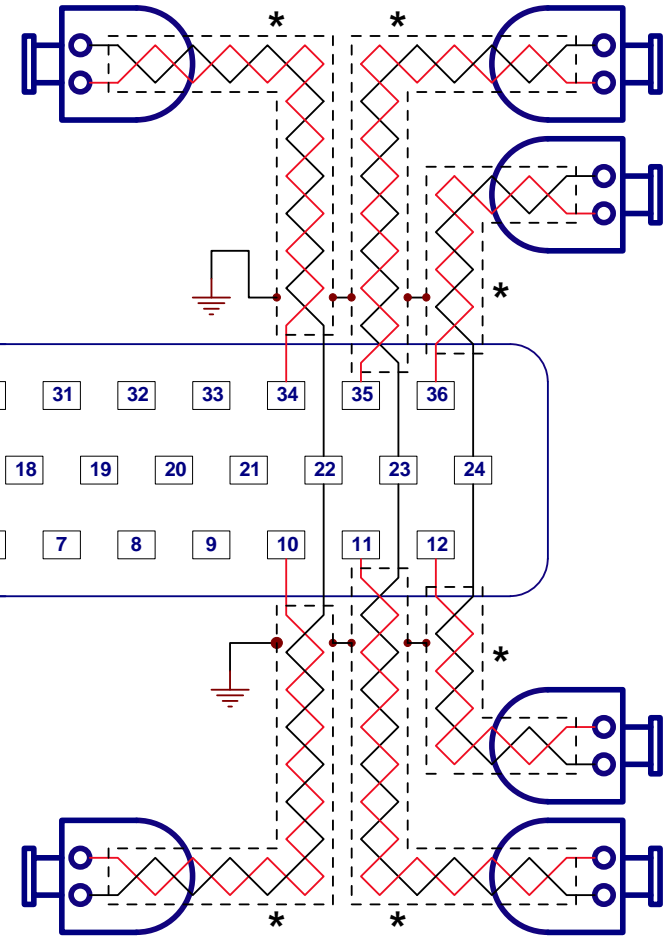

- \* Use twisted shielded cable grounded at one end only
- \*\* Shielded power cables required for Australian EMC compliance

Title			SHIELDING & EMC COMPLIANCE		
Size	Number		Revision		
A4	(C) M&W Ignitions		07.06.13.1		
Date:	7-Jun-2013		Sheet 1 of 1		
File:	D:\M&W\...\EMC.sch		Drawn By: M&W		