



PRO-18c

8 CHANNEL

(AUTRONIC MULTIPLEX)

CAPACITOR DISCHARGE IGNITION

SALES@MWIGNITIONS.COM
Ph. +61-2-9668-8481

CONTENTS:

2. Caution
3. Installation notes
7. Ignition coil information
8. Mounting dimensions
9. Connections and specifications
10. 8 cylinder direct fire ignition
11. Shielding & EMC compliance

**CHECK WEBSITE FOR UPDATED INSTRUCTIONS &
ADDITIONAL INFORMATION**

CAUTION

**THIS WIRING DIAGRAM IS
APPLICABLE ONLY TO IGNITION
SYSTEMS WITH SERIAL NUMBER
PREFIX STARTING**

49xxxx

**USE OF INCORRECT DIAGRAM WILL
VOID WARRANTY AND MAY DAMAGE
UNIT**

**THE INSTALLATION OF HIGH ENERGY IGNITION
SYSTEMS MAY REQUIRE ADVANCED
KNOWLEDGE AND SKILLS.**

**IMPROPER INSTALLATION OR OPERATION OF
THIS UNIT COULD CAUSE DAMAGE TO IGNITION
SYSTEM AND IGNITION COIL**

INSTALLATION NOTES

(Autronic Multiplex pro series street systems only)

MOUNTING

Do not mount the unit where it will be exposed to water or other liquids, ensure the bottom condensation slots are unobstructed and oriented to permit gravity drain. Select a location away from intense heat and if required provide a source of cooling air to remove internally generated heat.

Failure to use supplied rubber mounts will void warranty! Suitable replacement anti vibration mounts are M&W #MNT002, or Paulstra Radiaflex #521128.

IGNITION LEADS

Do not use plain metal wire or carbon core ignition leads.

Use spiral wound inductively suppressed metal core ignition leads such as those available from Magnecor www.magnecor.com.

SPARK PLUGS

The use of use non resistor spark plugs (where possible) will greatly enhance ignition performance.

In some installations the use of resistor spark plugs may be unavoidable. In these cases ensure they are not damaged by testing internal resistance value as part of regular maintenance. Open circuit or high resistance may cause failure of spark plug wires, ignition coils and CDI.

Surface discharge and semi surface discharge spark plugs are designed for use with CDI ignition however be aware they have a large non-adjustable spark gap suitable only for naturally aspirated or low boost applications.

INSULATION PRECAUTIONS

Degrease spark plug insulators and coil/plug boots after handling to prevent tracking or insulation breakdown.

Use (supplied) dielectric grease on spark plug insulators and coil/plug boots to increase insulation properties and ease installation/removal. Use of dielectric grease in main connector may reduce water ingress.

WIRING & POWER SUPPLY

M&W CDI systems are designed to blow the external fuse under conditions of over voltage or reverse polarity. Faults such as loose battery terminals, poor wiring or defective alternator/regulator may also cause for this to occur. Fitting a larger capacity fuse won't disable this feature, will void warranty and may cause irreparable damage to unit. **Only fit the recommended size fuse!**

Main connector pins are designed to be roll crimped. Squeeze crimping or soldering will cause distortion resulting in misfiring or incorrect CDI operation.

Wire ignition system directly to battery. If required wire length exceeds recommendations use small paired battery cable (power and ground) to make up distance. Do not rely on vehicle chassis to provide ground path. If connected to a high impedance supply shared with ECU or its sensors erratic operation will be experienced.

Do not use voltage boosters as most can't provide the instantaneous current required for correct CDI operation.

When using a total loss electrical system install either a 16V or 18V battery to ensure adequate supply voltage. If using extended voltage batteries isolate them during charging to prevent excessive voltage reaching the CDI and ECU.

Use twisted pair wire for all power and coil connections. For improved noise suppression and to comply with Australian EMC 'C Tick' standards use twisted shielded pair wire for coils. Twisted pair wire must be used for power/ground. Keep coil wires one continuous length from CDI and do not fit any intermediate connectors into harness. All coil negative wires must be joined at or in the cdi connector. Keep coil primary (CDI) wires away from HT leads, coil HV outlet and coil body to prevent a flashover occurring.

TRIGGERING

Autronic ECU multiplex trigger setup:

Go to 'Ignition setup' under menu M1 (Autronic config software)

Open 'Ignition O/P's' and select appropriate 'Mux' cyl configuration

Open 'Ign trigger edge' and select '-ve edge(PULSE)'
Open 'Dwell/pulse times' and select 'Autronic CDI SS'
Open 'Ign delay time' and set to 0 usec

Autronic multiplex CDI will not fire if ECU has not achieved sync with engine!

POWER LEVEL SWITCH

Some M&W Pro street systems are provided with a (active low) power level switch. Do not manually activate this feature or operate continuously as this will significantly increase spark plug wear and system current draw. Activate by grounding input through either a 'Hobbs' style manifold pressure switch or programmable output from the ECU when elevated energy levels are required.

TWO SPARK SWITCH

Some M&W Pro street systems are provided with a two spark switch for part load conditions in lean burn engines. Do not manually activate this feature as it will significantly increase spark plug wear and double system current draw. Activate by grounding the input through a programmable ECU output.

TUNING

M&W CDI systems may reduce combustion delay and percentage misfire requiring a reduction in ignition timing. The resulting changes in combustion characteristics may also require alterations to fuel flow.

Always re tune both fuel and timing curves after installing CDI ignition.

TACHO OUTPUT

The tacho output provides a 50% duty cycle square wave signal at battery supply voltage. This will work with most aftermarket digital tacho's however earlier types and those designed for coil negative triggering may not read accurately.

LED INDICATOR

After applying power to switch wire the LED will illuminate for 1 second and extinguish. The LED will then flash briefly with each

consecutive trigger event received (it may be necessary to view the LED directly on axis).

A repeated double flash of the LED may indicate a possible faulty ignition coil, faulty wiring, low supply voltage or damage to the CDI.

TESTING

The cdi may be fired by momentarily grounding trigger inputs however due to the multiplex trigger scheme used it may be necessary to consult Autronic documentation to ascertain which inputs or input pairs are used to fire the appropriate output.

Do not conduct this test without grounded spark plugs installed!

A more comprehensive test procedure may be found on our web site http://www.mwignitions.com/pg_data_sheets.php

INSTALLATION PRECAUTIONS

The main cause of CDI damage is conduction of high voltage to coil primary wiring.

Care must be taken due to the propensity for HV flashovers and insulation breakdown caused by CDI ignitions unique characteristics.

It is important to fully read and understand these instructions and have a good knowledge of automotive electrical systems before commencing installation.

For further instructions and cdi information check out the support tab on our web site <http://www.mwignitions.com>

IGNITION COILS

(Pro-Street systems only)

COIL SELECTION

Most inductive ignition coils will work reasonably well with CDI systems however for ultimate ignition energy and efficiency use a coil specifically designed for CDI use.

COP COILS

COP (coil on plug) coils with inbuilt drivers are not suitable for use with CDI ignition. COP coils designed for inductive ignition may contain a blocking diode in the secondary winding which must be considered during wiring (see coil polarity note below). **Use resistive spark plugs with all COP coils. Keep plug gap < 0.025" (0.6mm) to prevent coil damage. DO NOT use AEM pencil coils under any circumstances!**

FERRITE CDI COILS

Ferrite core cdi coils provide a lightweight solution for direct fire applications and give high secondary current however they may not be suitable for all applications due to their extremely short arc duration. The high level of EMI emitted by these coils may also require additional shielding to prevent electrical interference with the ECU or CDI. **Do not use ferrite coils in parallel wired pairs!**

COIL POLARITY

All diagrams are shown for cdi style coils. For correct operation with inductive ignition coils wire the primary connections in reverse to maintain correct spark plug polarity.

CAUTION!

**IGNITION COIL DAMAGE MAY OCCUR IF
OPERATED WITH AN EXCESSIVE SPARK GAP**

CAUTION!
HIGH VOLTAGE



**DISCONNECT POWER BEFORE
WORKING ON UNIT**

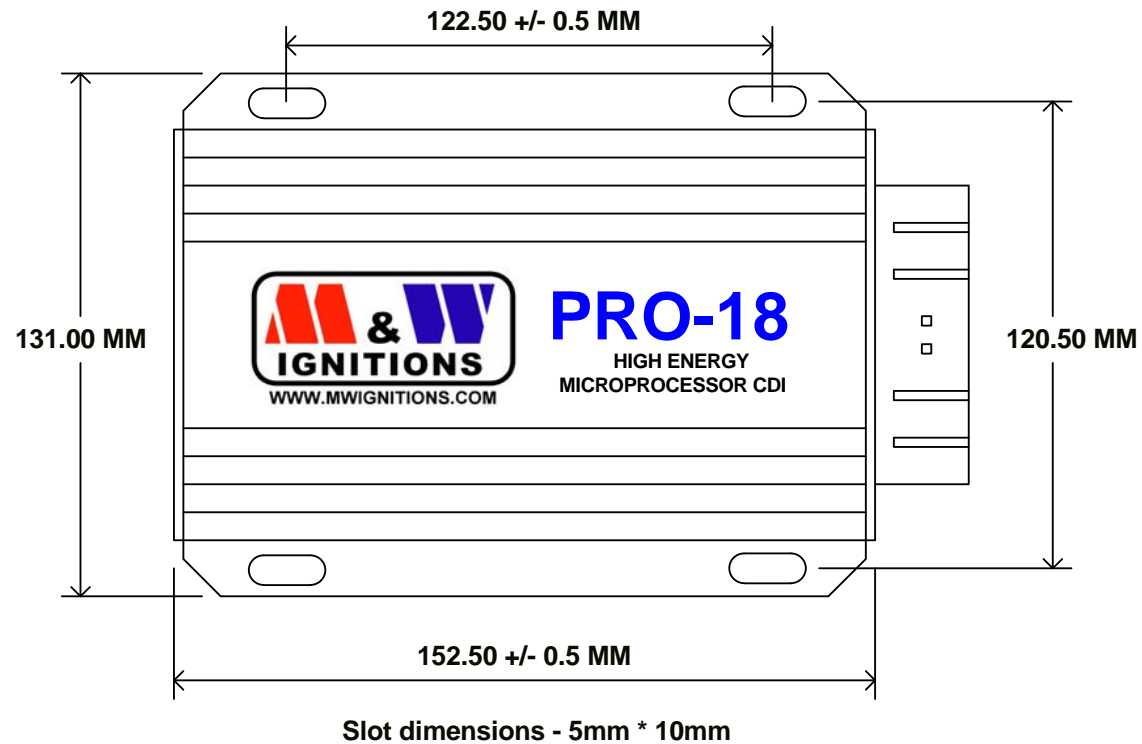

Title				PRO-18c MOUNTING DIMENSIONS	
Size	Number	(C) M&W Ignitions		Revision	
A4				08.06.13.1	
Date:	8-Jun-2013	Sheet 1 of 1			
File:	D:\M&W\...\Mounting dimensions.sch	Drawn By:		M&W	

**CAUTION!
HIGH VOLTAGE**



**DISCONNECT POWER BEFORE
WORKING ON UNIT**

M & W IGNITIONS

Performance & Quality since 1996

VIEWED FROM BACK OF CONNECTOR



KEEP ALL INPUTS WELL SEPARATED FROM COIL OUTPUTS

1 +12V (Battery)	13 Ground (Battery)	25 IGNITION 2 (*6)
2 +12V (Battery)	14 Ground (Battery)	26 Ignition switch
3 IGNITION 1 (*5)	15	27
4	16 IGNITION 3 (*19)	28
5	17	29 IGNITION 4 (*33)
6 Tacho	18 Shield	30
7	19	31
8	20	32
9 **Coil 7 +	21 Coil 7 & 8 -	33 **Coil 8 +
10 **Coil 5 +	22 Coil 5 & 6 -	34 **Coil 6 +
11 **Coil 3 +	23 Coil 3 & 4 -	35 **Coil 4 +
12 **Coil 1 +	24 Coil 1 & 2 -	36 **Coil 2 +

**** FIRING SEQUENCE NOT CYLINDER NUMBER
* SM4 PIN NUMBERS**

SPECIFICATIONS

Supply voltage = 13V - 18V DC negative ground
 Startup voltage = +6V
 Maximum supply current = 7.0A
 Power off current < 700uA
 Maximum ignition frequency - 1,200Hz
 Maximum energy limit = 700 Hz
 Coil primary voltage = 480V
 Spark energy = 115 millijoules
 Trigger = Autronic multiplex 4 wire
 Tacho = 12V, 100mA square wave
 Maximum case temperature = 105°C
 Dimensions = 152L * 110W * 40H
 Weight = 740gm

Title 8 CHANNEL AUTRONIC MULTIPLEX		
Size A4	Number (C) M&W Ignitions	Revision 25.06.13.1
Date: 25-Jun-2013	Sheet 1 of 1	Drawn By: M&W
File: D:\M&W\...\Pro18C_S3_1.sch		

CAUTION!
HIGH VOLTAGE



DISCONNECT POWER BEFORE
WORKING ON UNIT

M & W IGNITIONS

Performance & Quality since 1996

Note!
Use 20 gauge wire
Twist wires 1 turn in 20mm
Maximum wire length 2M

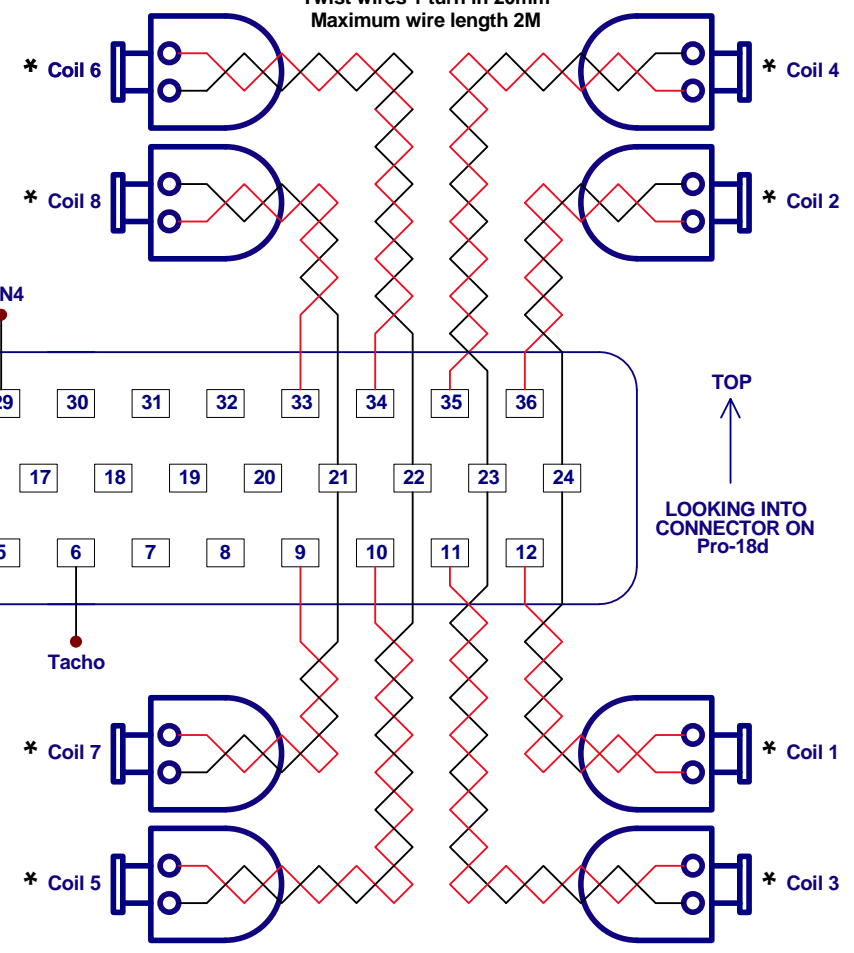

↑ TOP
LOOKING INTO
CONNECTOR ON
Pro-18d

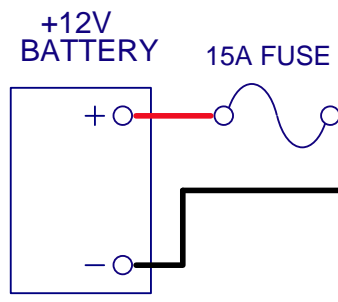
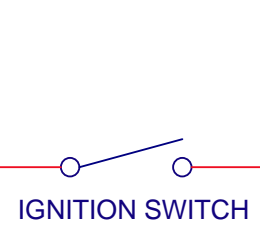

* FIRING ORDER NOT CYLINDER NUMBER

Title			8 CHANNEL SEQUENTIAL IGNITION		
Size	Number		Revision		
A4	(C) M&W Ignitions		08.06.13.1		
Date:	8-Jun-2013		Sheet 1 of 1		
File:	D:\M&W\...\Pro18C_S3_2.sch		Drawn By: M&W		

CAUTION!
HIGH VOLTAGE



**DISCONNECT POWER BEFORE
WORKING ON UNIT**

M & W IGNITIONS

Performance & Quality since 1996

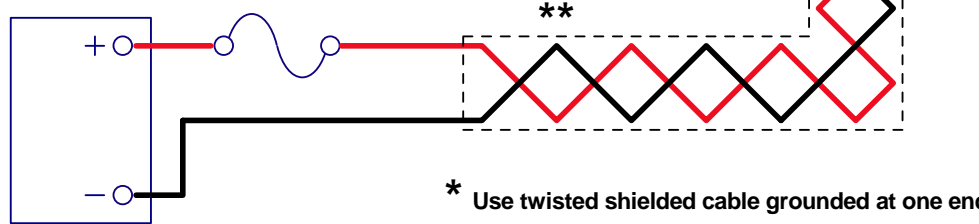
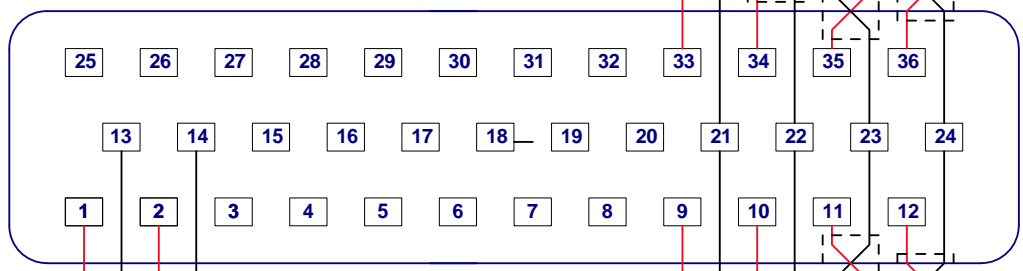
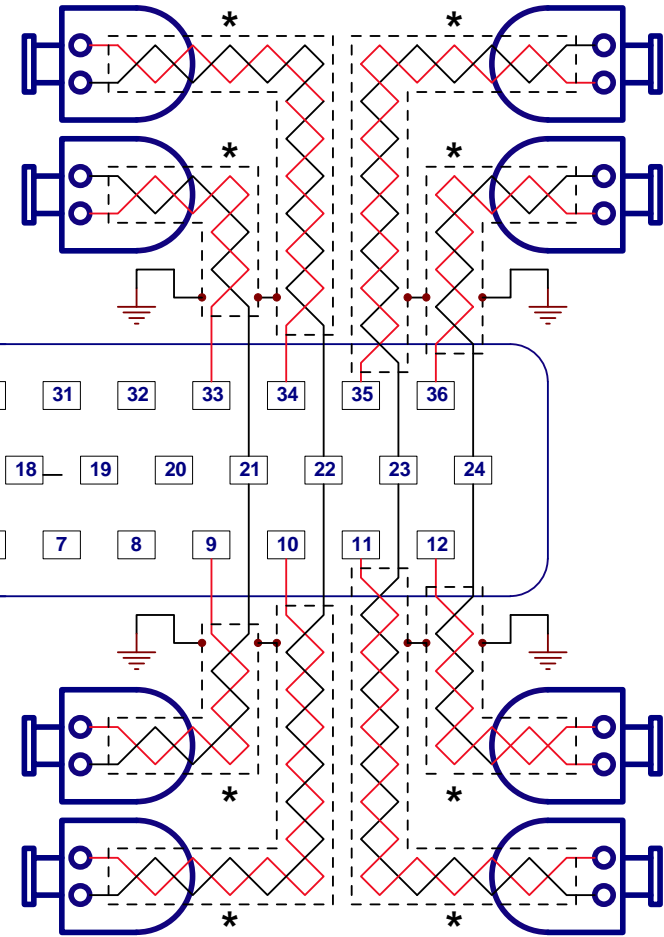

* Use twisted shielded cable grounded at one end only
** Shielded power cables required for Australian EMC compliance

Title			SHIELDING & EMC COMPLIANCE		
Size	Number		Revision		
A4	(C) M&W Ignitions		08.06.13.1		
Date:	8-Jun-2013		Sheet 1 of 1		
File:	D:\M&W\...\EMC.sch		Drawn By: M&W		