



1000 Max2

ELECTRICAL WIRING & OPERATING INSTRUCTIONS

Applicable
S/No's 93xxxx

**FAILURE TO FOLLOW INSTRUCTIONS
WILL VOID WARRANTY**

CONTENTS

2. Installation notes
8. Connections and specifications
9. Top Fuel Harley (two box)
10. 2 rotor Mazda (two box)
11. 4 cylinder reciprocating
12. 6 cylinder reciprocating (two box)
13. 8 cylinder reciprocating (two box)
14. Mounting dimensions



WARNING

This is an Extreme ignition system and designed for short duration use on drag race only vehicles!

SAFE OPERATION

It is important to correctly sequence activation and deactivation of ignition system to prevent uncommanded ignition events.

- CDI must be connected directly to battery and turned on/off via CDI switch input
- ECU must be fully initialised and all ignition output lines in a stable state before cdi is turned on
- CDI must be turned off via cdi switch input at least 500mS prior to ECU shutdown
- Do not connect or disconnect cdi power supply with power applied to cdi switch input

MOUNTING

Mount the unit in a dry location away from intense heat and ensure bottom condensation slots are unobstructed and oriented to permit gravity drain. Ensure a source of cooling air is available.

Failure to use supplied rubber mounts will void warranty!

Unit must be secured with no preload on rubber mounts in any axis and incapable of contacting any rigid part of the vehicle during rubber deflection.

IGNITION LEADS

Use only inductively suppressed spiral wound metal conductor ignition leads. For best performance select leads with approximately 1,000 ohms per metre (300 ohm per ft) resistance.

Do not use carbon core or unsuppressed metal leads!

SPARK PLUGS

When using resistor spark plugs check resistance as part of regular maintenance, replace immediately if out of tolerance. Do not use semi or full surface discharge spark plugs on boosted motors.

Keep spark plug gap ≤ 0.025 " (0.6mm) for boosted motors!

INSULATION PRECAUTIONS

Regularly degrease sparkplug insulators, coil HV towers, sparkplug boots, ignition coil boots and installation tooling to prevent high voltage arcing.

Use only clean dry gloves to handle spark plugs once clean!

Use dielectric grease on sparkplug insulators, coil tower, inside sparkplug boots and ignition coil boots to improve insulation properties and ease installation/removal.

POWER SUPPLY

Reverse polarity will damage unit!

Always install external fuse or equivalent rated circuit breaker!

Best performance will be achieved using a 16V electrical system. For total loss applications a minimum 12Ah lithium battery should be used with a separate ECU power supply for reduced interference.

Disconnect battery during charging!

Shutdown voltage	<6.5V	
Start-up voltage	>7.0V	
Performance limited region	<13.5V	
Minimum operating voltage	14.0V	(max speed 360Hz/box)
Normal operating voltage	16.0V	(max speed 420Hz/box)
Maximum operating voltage	18.0V	(max speed 460Hz/box)

Connect power supply +/- inputs directly to battery, do not wire through PDM or other electrical management system!

WIRING

Use twisted shielded Tefzel M27500 for all wires and keep short as possible. See install diagram for correct gauge.

Keep coil primary wires well separated from HT leads, coil HV outlet, coil body and any ECU wiring!

TRIGGERING

Single box reciprocating - ignition channels may be triggered in any sequence, two box reciprocating - firing sequence must alternate between boxes. All other motors to follow diagram.

1000 Max2 systems default to falling (negative) edge trigger, to select rising edge (positive) trigger join pins 5 (Trigger edge) & 17 (Edge ground).

Note! Trigger edge input is only monitored at startup and can not be changed while running.

We strongly suggest the use of falling edge triggering!

POWER LEVEL SWITCH

Power level switch is used to reduce ignition load under low engine power conditions.

Activate high power mode by grounding input through 'Hobbs' style manifold pressure switch or programmable output from ECU when increased ignition energy is required.

Unless indicated otherwise and where ever possible do not manually or permanently activate this feature!

CDI SWITCH

CDI switch input is used for powering system up/down without disconnection from battery. Once switch input is enabled unit will conduct self test and boot sequence in preparation for operation. This input is not suitable for rapid interruption of ignition function.

HIGH SPEED ENABLE

High speed enable input allows for rapid interruption of ignition function without complete shutdown. A fast reaction time ($< 30\mu\text{s}$) ensures suitability for ignition cut gear change etc. This input may also be used to temporarily disable ignition system while maintaining CAN data output however operation in this mode will limit cooling as generator remains active.

THERMAL MANAGEMENT

A cooling airflow will assist temperature recovery however it does not extend operation time!

Active temperature monitoring is used to prevent inadvertent damage through operation outside design parameters. If internal temperature exceeds 180°C ignition system will shut down without warning and restart once temperature is below 80°C .

Present and peak temperature may be monitored via can data stream.

TACHO OUTPUT

Tacho output provides a 1.5mS low going pulse 1V below supply voltage (alternative custom options available).

LED INDICATOR

Power up: Led's will flash alternately until supply exceeds 7V .

Boot: Both Led's illuminated steady for approx 1 second.

Normal operation: Green led will flash with each trigger input detected, red led will illuminate when high power mode active.

Over temperature: Both LED's will flash simultaneously until transformer temperature below 80°C

Output damage: A repeated triple flash of red led.

CAN BUS DATA

Protocol: 1Mbps - 11 bit ID
CAN ID: 0x100 (0x101 secondary) - custom available
Data rate: 10Hz
Termination: No internal terminating resistor fitted.
Firmware: V 0.1

Byte No.	Description	Unit	Multiplier
1	Present temperature	°C	1
2	Peak temperature	°C	1
3	Present internal supply voltage	V	0.1
4	Peak internal supply voltage	V	0.1
5	Flags (see below)		
6	Firmware version		
7	Serial number high byte		
8	Serial number low byte		
	Flags		
Bit 7	Drive current	0 - Low	1 - High
Bit 6	Power level selection	0 - Low	1 - High
Bit 5	Trigger edge selected	0 - Rise	1 - Fall
Bit 4	High speed enable	0 - Stop	1 - Run
Bit 3	N/A		
Bit 2	N/A		
Bit 1	N/A		
Bit 0	N/A		

TUNING

CDI performance is not affected by changes in dwell settings!

CDI ignition will significantly alter combustion characteristics requiring an alteration of ignition timing and fuel flow maps.

Do not attempt to re-use exiting timing curves, set ECU ignition delay to zero and re-tune both fuel and timing after installation!

COIL SELECTION

Use only M&W COI006-18 coils or contact us for alternate recommendations.

Do not use COP coils, pencil coils or ferrite core coils such as Mercury, Profex or MSD 8201

TESTING

When fault finding new installations the CDI may be manually fired by individually and momentarily grounding each trigger input. If installed correctly this will cause the green LED to briefly flash and corresponding ignition coil to spark.

Do not conduct this test without grounded spark plugs installed!

SAFETY

This cdi system is capable of generating extreme voltages at high current!

We strongly advise the provision of spark plug lead grounding points on all vehicles using this ignition.

These may simply be old spark plugs or sparkplug shaped metal studs welded & grounded to vehicle chassis.

Immediately prior to maintenance, either electronic or mechanical, remove spark plug leads from spark plugs and attach to grounding points.

This will help prevent coil/lead/cdi damage and possible injury to nearby personnel.

M & W IGNITIONS

Unsurpassed Performance & Quality

CAUTION!
HIGH VOLTAGE



**DISCONNECT POWER BEFORE
WORKING ON UNIT**



SPECIFICATIONS

Operating voltage	14.0V --> 18V DC
Startup voltage	>= 7V
Maximum supply current	45A (per Box)
Power off current	< 700uA
Minimum full power RPM @ 16V supply voltage	
4 cyl (1 box)	12,450 rpm
2 rotor (2 box)	12,450 rpm
6 cyl (2 box)	16,600 rpm
8 cyl (2 box)	12,450 rpm
Spark energy (per plug):	
Low power	600mJ
High power	1,015mJ
Coil current	170A
Trigger:	
Current	10mA
Edge	Adjustable
Voltage rising	>= 3.2V
Voltage falling	<= 1.6V
Tacho output:	
Voltage	Supply - 1.2V
Output current	100mA
Shape	1.5mS low transition
Operating temperature	<= 105°C
Dimensions	179L * 137W * 50H
Weight	1,200gm (per box)

1 +12V (Battery)	13 Ground (Battery)	25 Trigger 1
2 +12V (Battery)	14 Ground (Battery)	26 CDI switch
3 +12V (Battery)	15 Ground (Battery)	27 Trigger 2
4 +12V (Battery)	16 Ground (Battery)	28 Trigger 3
5 Trigger edge	17 Edge ground	29 Trigger 4
6 Tacho	18	30 High speed enable
7	19 CAN High	31 Power level
8	20	32 CAN Low
9	21 Coil 4 -	33
10 Coil 3 +	22 Coil 3 -	34 Coil 4 +
11	23 Coil 1 -	35
12 Coil 1 +	24 Coil 2 -	36 Coil 2 +

Title			SPECIFICATIONS		
Size	Number	(C) M&W Ignitions		Revision	
A4				10.03.21.1	
Date:	10-Mar-2021	Sheet	1 of 1	Drawn By:	WAG
File:	D:\M&W\1000 Max2 - specs.sch				

Wire Specifications

POWER SUPPLY:

Use 12ga shielded wire from battery quadfurcated into 18ga wire <= 100mm from connector. Junction is best achieved using a Solistrand or similar butt splice / barrel crimp.

Maximum recommended wire length is 2M

IGNITION COILS:

Use 18ga shielded wire from cdi to coils and keep as one continuous length.

Maximum recommended wire length is 2M

Read installation guide for important wiring details!

Note!

C1P1 = Cylinder 1, Plug 1
 C1P2 = Cylinder 1, Plug 2
 C2P1 = Cylinder 2, Plug 1
 C2P2 = Cylinder 2, Plug 2

BATTERY

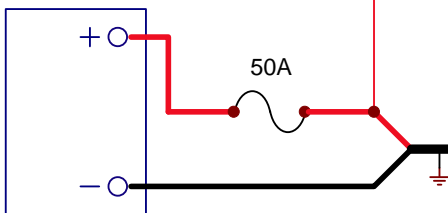

Reverse polarity connection without fuse installed will damage unit!

M & W IGNITIONS

Unsurpassed Performance & Quality

**CAUTION!
HIGH VOLTAGE**



DISCONNECT POWER BEFORE WORKING ON UNIT

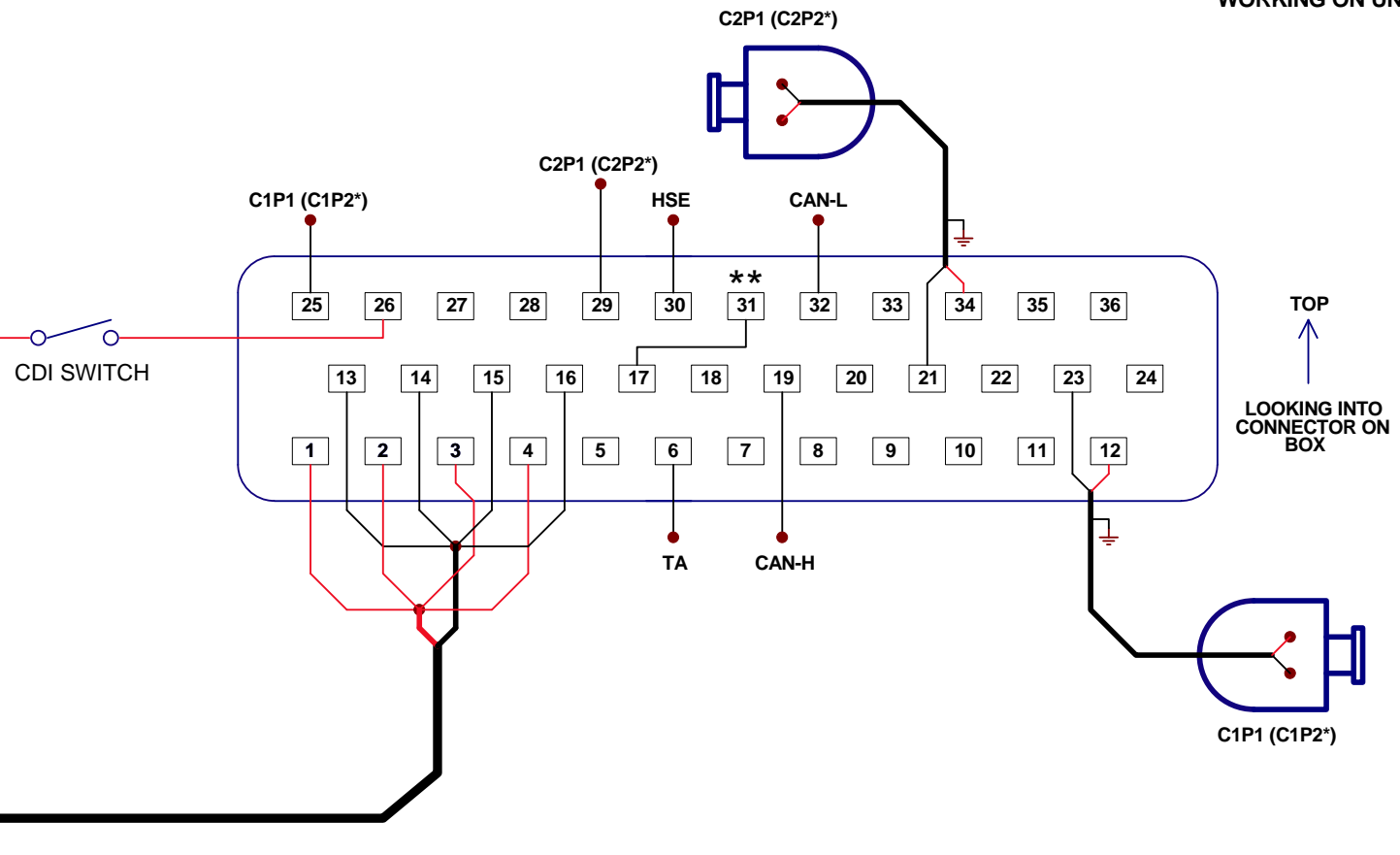

↑ TOP
LOOKING INTO CONNECTOR ON BOX

* Indicates wiring for second box
 ** Hi power mode selected full time

Title			TOP FUEL HARLEY		
Size	Number	Revision			
A4		(C) M&W Ignitions		19.02.21.1	
Date:	19-Feb-2021	Sheet 1 of	1		
File:	D:\M&W\...\1000 Max2 TFH.sch	Drawn By:	WAG		

Wire Specifications

POWER SUPPLY:

Use 12ga shielded wire from battery quadfurcated into 18ga wire <= 100mm from connector. Junction is best achieved using a Solistrand or similar butt splice / barrel crimp. Maximum recommended wire length is 2M

IGNITION COILS:

Use 18ga shielded wire from cdi to coils and keep as one continuous length. Maximum recommended wire length is 2M

Read installation guide for important wiring details!

M & W IGNITIONS

Unsurpassed Performance & Quality

**CAUTION!
HIGH VOLTAGE**



DISCONNECT POWER BEFORE WORKING ON UNIT

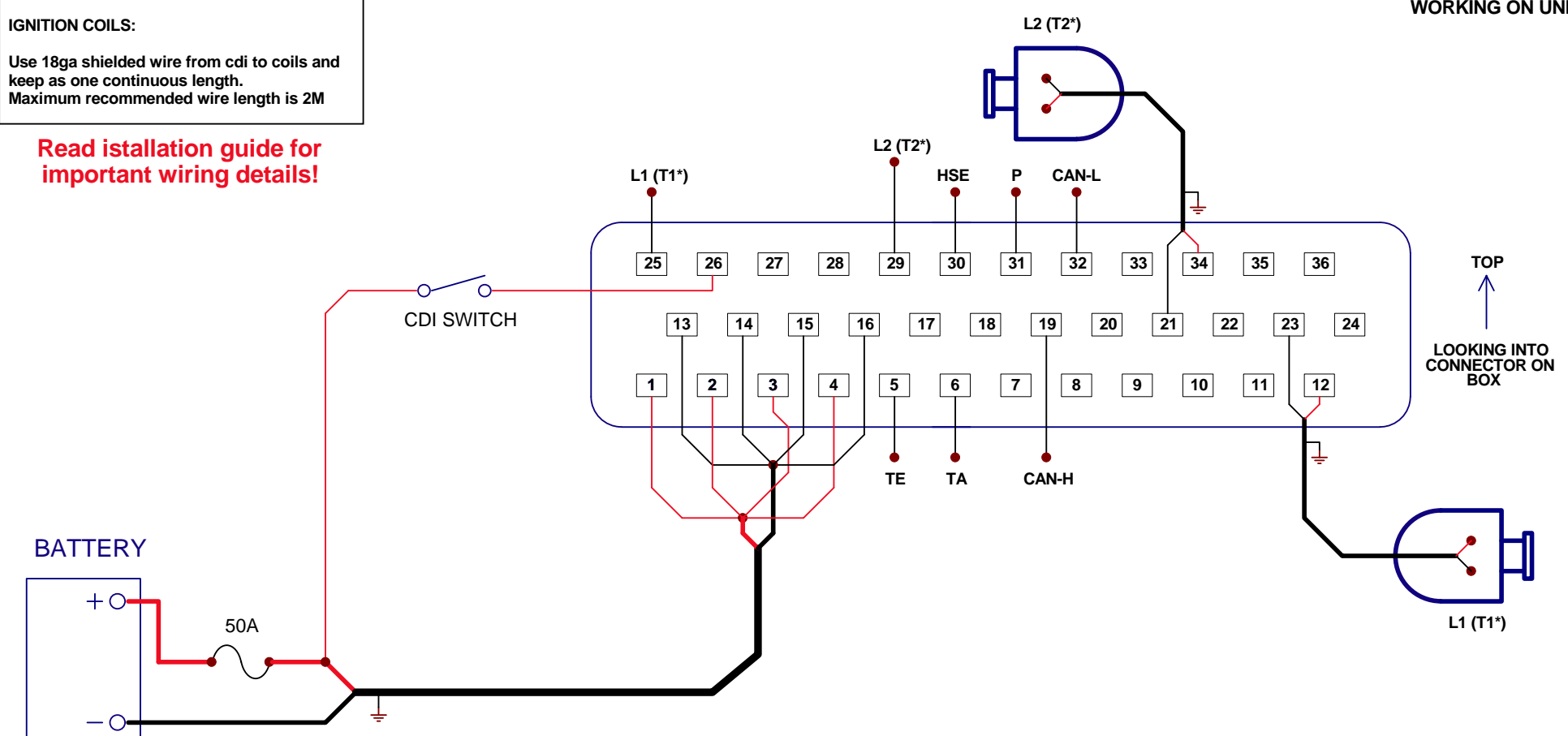

TOP
↑
LOOKING INTO CONNECTOR ON BOX

Reverse polarity connection without fuse installed will damage unit!

* Indicates wiring for second box

Title			2 ROTOR		
Size	Number	Revision			
A4		(C) M&W Ignitions		06.02.21.1	
Date:	6-Feb-2021	Sheet1 of	1		
File:	D:\M&W\...\1000 Max2 - 2 rotor.sch	Drawn By:	WAG		

Wire Specifications

POWER SUPPLY:

Use 12ga shielded wire from battery quadfurcated into 18ga wire <= 100mm from connector. Junction is best achieved using a Solistrand or similar butt splice / barrel crimp. Maximum recommended wire length is 2M

IGNITION COILS:

Use 18ga shielded wire from cdi to coils and keep as one continuous length. Maximum recommended wire length is 2M

Read installation guide for important wiring details!

M & W IGNITIONS

Unsurpassed Performance & Quality

**CAUTION!
HIGH VOLTAGE**



DISCONNECT POWER BEFORE WORKING ON UNIT

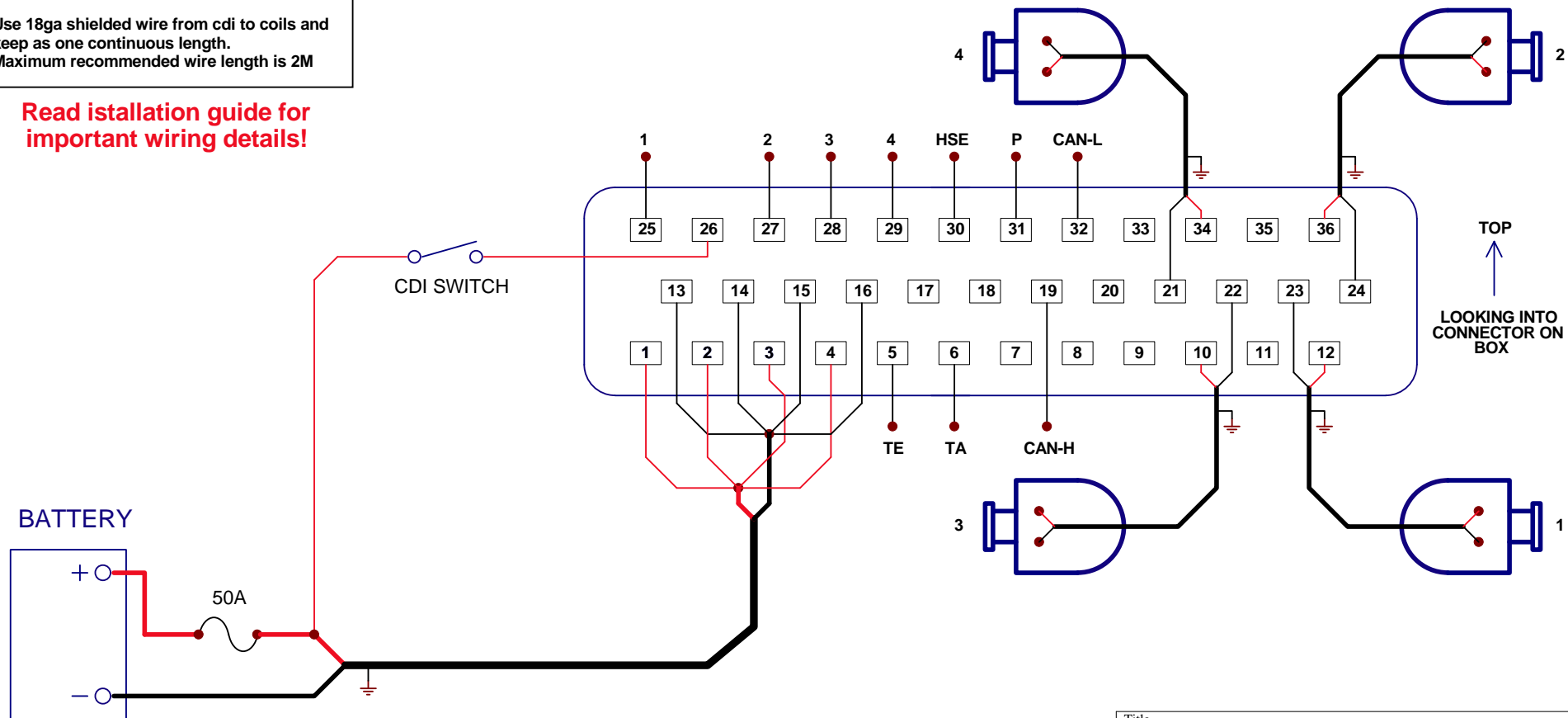

TOP
↑
LOOKING INTO CONNECTOR ON BOX

Reverse polarity connection without fuse installed will damage unit!

Title			4 CYLINDER
Size	Number	Revision	
A4		(C) M&W Ignitions	06.02.21.1
Date:	6-Feb-2021	Sheet 1 of 1	
File:	D:\M&W\1000 Max2 - 4 cylinder.sch	Drawn By:	WAG

Wire Specifications

POWER SUPPLY:

Use 12ga shielded wire from battery quadfurcated into 18ga wire <= 100mm from connector. Junction is best achieved using a Solistrand or similar butt splice / barrel crimp.
Maximum recommended wire length is 2M

IGNITION COILS:

Use 18ga shielded wire from cdi to coils and keep as one continuous length.
Maximum recommended wire length is 2M

Read installation guide for important wiring details!

M & W IGNITIONS

Unsurpassed Performance & Quality

**CAUTION!
HIGH VOLTAGE**



DISCONNECT POWER BEFORE WORKING ON UNIT

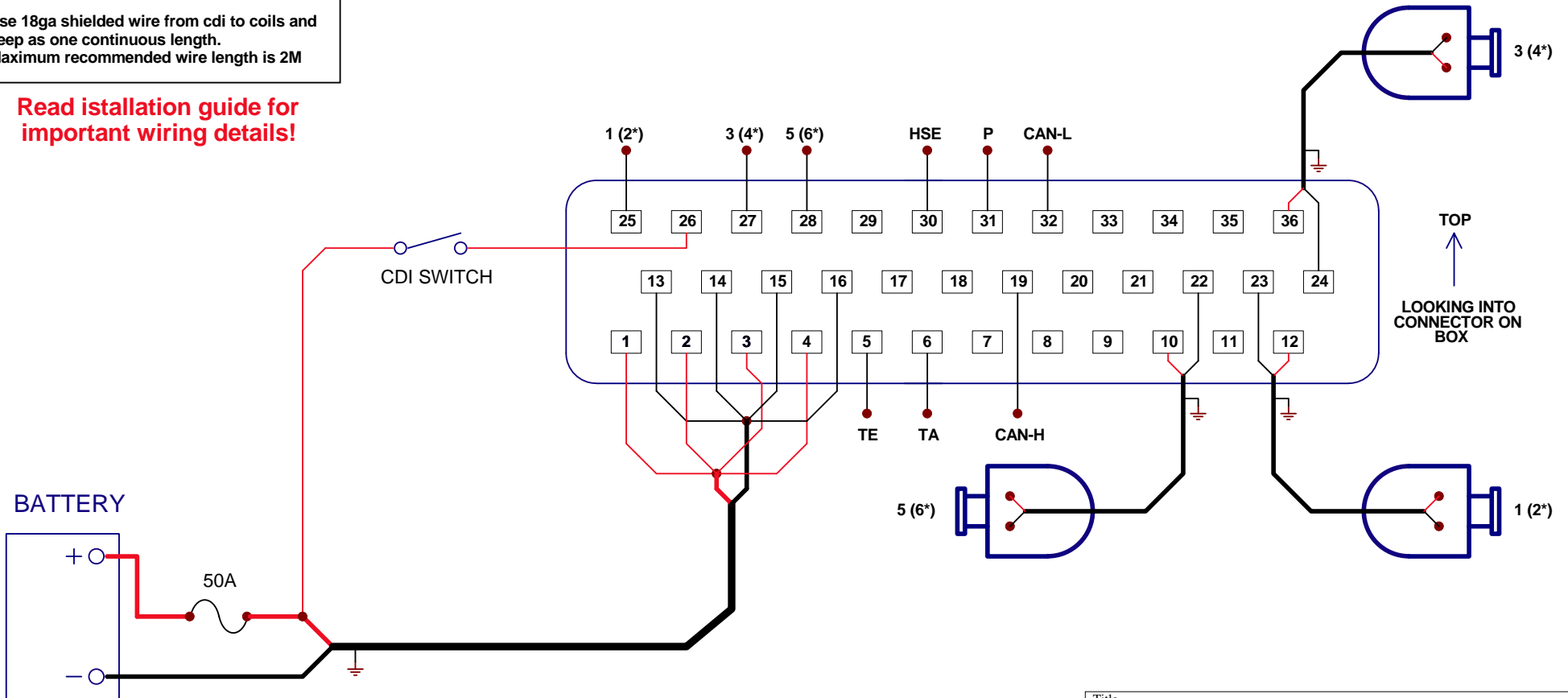

TOP
↑
LOOKING INTO CONNECTOR ON BOX

Reverse polarity connection without fuse installed will damage unit!

* Indicates wiring for second box

Title			6 CYLINDER		
Size	Number	Revision			
A4		(C) M&W Ignitions		06.02.21.1	
Date:	6-Feb-2021	Sheet 1 of	1		
File:	D:\M&W\1000 Max2 - 6 cylinder.sch	Drawn By:	WAG		

Wire Specifications

POWER SUPPLY:

Use 12ga shielded wire from battery quadfurcated into 18ga wire <= 100mm from connector. Junction is best achieved using a Solistrand or similar butt splice / barrel crimp. Maximum recommended wire length is 2M

IGNITION COILS:

Use 18ga shielded wire from cdi to coils and keep as one continuous length. Maximum recommended wire length is 2M

Read installation guide for important wiring details!

M & W IGNITIONS

Performance & Quality

**CAUTION!
HIGH VOLTAGE**



DISCONNECT POWER BEFORE WORKING ON UNIT

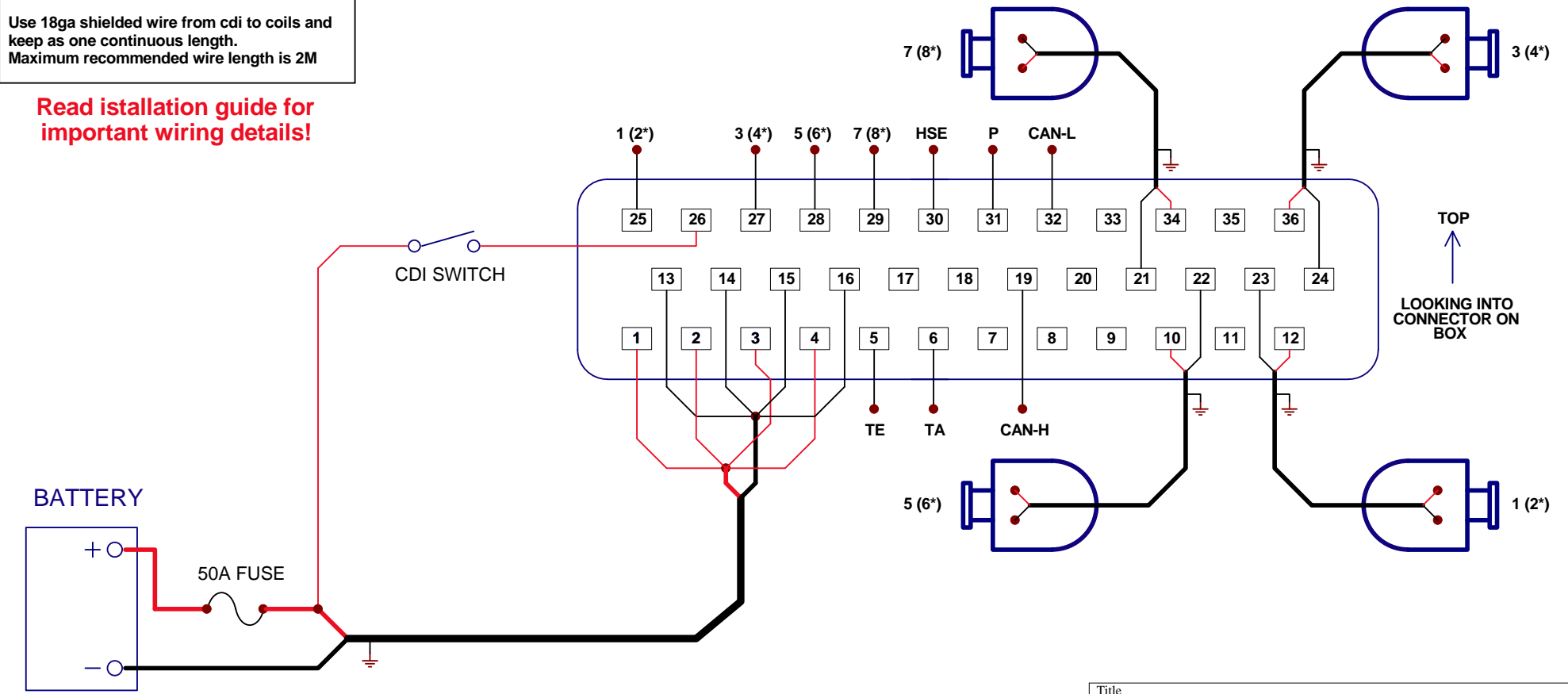

TOP
↑
LOOKING INTO CONNECTOR ON BOX

Reverse polarity connection without fuse installed will damage unit!

* Indicates wiring for second box

Title			8 CYLINDER		
Size	Number	Revision			
A4		(C) M&W Ignitions		06.02.21.1	
Date:	6-Feb-2021	Sheet 1 of	1		
File:	D:\M&W\1000 Max2 - 8 cylinder.sch	Drawn By:	WAG		

CAUTION!
HIGH VOLTAGE



**DISCONNECT POWER BEFORE
WORKING ON UNIT**

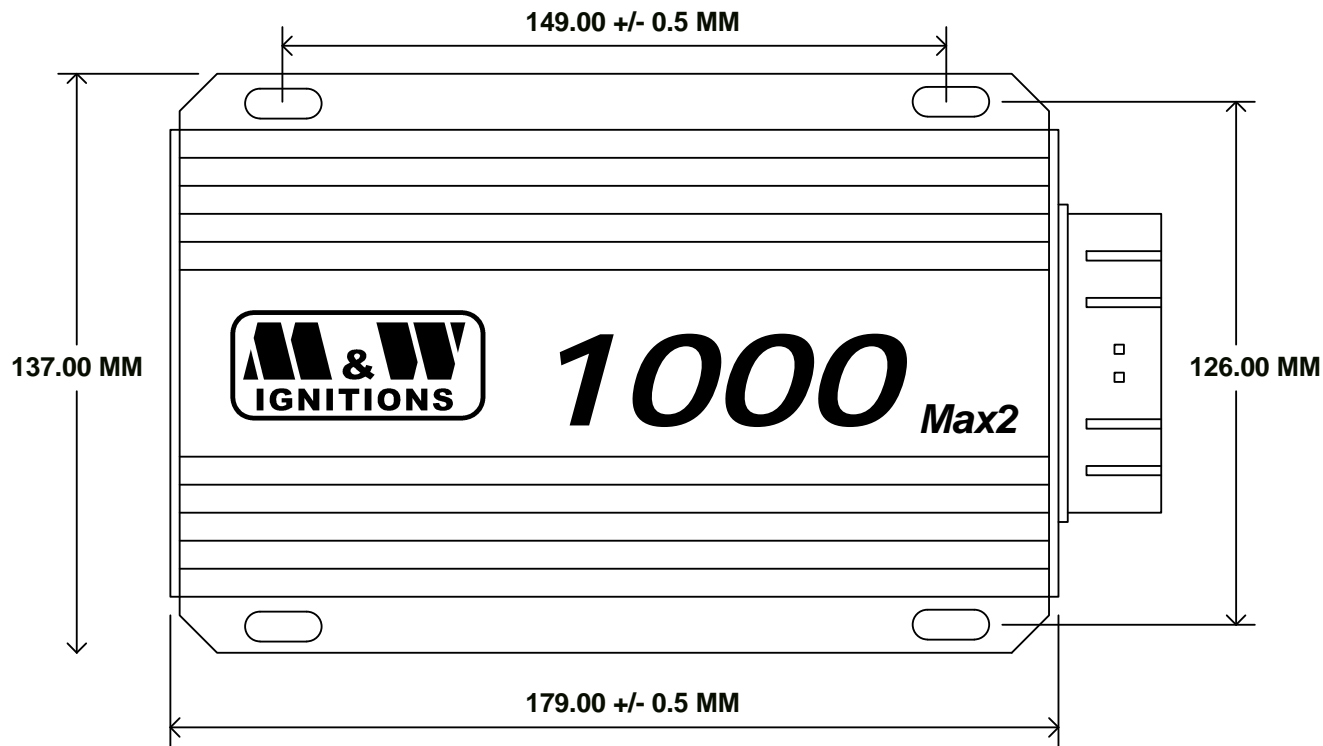

Slot dimensions - 5mm * 10mm

Title		1000 MAX2 CDI	
Size	Number	Revision	
A4	(C) M&W Ignitions	06.02.21.1	
Date:	6-Feb-2021	Sheet 1 of 1	
File:	D:\M&W\1000 Max Dimensions.sch	Drawn By:	WAG