



By



Platinum Power Select 4 CDI

HT-020203

4 CHANNEL IMS (Ignition Multiplex System)

CONTENTS:

2. Installation notes
5. Ignition coil information
6. Mounting dimensions
7. Connections and specifications
8. 4 cylinder direct fire ignition
9. Shielding & EMC compliance

INSTALLATION NOTES

(Ignition Multiplex Systems only)

MOUNTING

Do not mount the unit where it will be exposed to water or other liquids, ensure the bottom condensation slots are unobstructed and oriented to permit gravity drain. Select a location away from intense heat and if required provide a source of cooling air to remove internally generated heat.

Failure to use supplied rubber mounts will void warranty! Suitable replacement anti vibration mounts are M&W #MNT002, or Paulstra Radiaflex #521128.

IGNITION LEADS

Do not use plain metal wire or carbon core ignition leads.

Use spiral wound inductively suppressed metal core ignition leads such as those available from Magnecor www.magnecor.com.

SPARK PLUGS

Resistor spark plugs must be used!

INSULATION PRECAUTIONS

Degrease spark plug insulators and coil/plug boots after handling to prevent tracking or insulation breakdown.

Use (supplied) dielectric grease on spark plug insulators and coil/plug boots to increase insulation properties and ease installation/removal. Use of dielectric grease in main connector may reduce water ingress.

WIRING & POWER SUPPLY

Haltech CDI systems are designed to blow the external fuse under conditions of over voltage or reverse polarity. Faults such as loose battery terminals, poor wiring or defective alternator/regulator may also cause for this to occur. Fitting a larger capacity fuse won't disable this feature, will void warranty and may cause irreparable damage to unit. **Only fit the recommended size fuse!**

Main connector pins are designed to be roll crimped. Squeeze crimping or soldering will cause distortion resulting in misfiring or incorrect CDI operation.

Wire ignition system directly to battery. If required wire length exceeds recommendations use small paired battery cable (power and ground) to make up distance. Do not rely on vehicle chassis to provide ground path. If connected to a high impedance supply shared with ECU or its sensors erratic operation will be experienced.

Do not use voltage boosters as most can't provide the instantaneous current required for correct CDI operation.

When using a total loss electrical system install either a 16V or 18V battery to ensure adequate supply voltage. If using extended voltage batteries isolate them during charging to prevent excessive voltage reaching the CDI and ECU.

Use twisted pair wire for all power and coil connections. For improved noise suppression and to comply with Australian EMC 'C Tick' standards use twisted shielded pair wire for coils. Twisted pair wire must be used for power/ground. Keep coil wires one continuous length from CDI and do not fit any intermediate connectors into harness. All coil negative wires must be joined at or in the cdi connector. Keep coil primary (CDI) wires away from HT leads, coil HV outlet and coil body to prevent a flashover occurring.

IGN1 input from ECU must be shielded!

14ga twisted pair wire for power / ground - HT035001

20ga twisted shielded wire for coils – HT035004

Shield terminators HT035005 for use with HT035004 wire

TRIGGERING

Coil output numbers indicate engine cylinder number not CDI ignition sequence.

Haltech IMS system is a time multiplexed method for firing up to 12 ignition outputs using a single trigger wire.

Follow the manufacturers instructions to select Ignition Bus output from the ECU.

POWER LEVEL SWITCH

Haltech IMS systems are provided with a (active low) power level switch. Do not manually operate this feature as it will significantly increase spark plug wear and system current draw. Activate by connecting to Ignition Output #2 (IGN2) on your Haltech ECU.

TUNING

Always re tune fuel and timing curves after installing CDI ignition!

Use the Haltech tuning software to check and adjust "Trigger Angle" after installation.

Haltech CDI systems may reduce combustion delay requiring a reduction in overall ignition timing. Resulting changes in combustion characteristics may also necessitate alterations to the fuel flow map.

LED INDICATOR

After applying power to switch wire the LED will illuminate for 1 second and extinguish. The LED will then flash briefly with each correctly decoded trigger event received (it may be necessary to view the LED directly on axis).

A repeated double flash of the LED may indicate a possible faulty ignition coil, faulty wiring, low supply voltage or damage to the CDI.

TESTING

Due to the complexity of the Haltech IMS Bus signal a self test mode has been built into the firmware. By grounding Self test terminal prior to powering the unit it will sequentially fire all the outputs and flash the LED in sync. To exit the test mode disconnect power from the unit and remove connection to self text terminal.

Do not conduct this test without grounded spark plugs installed!

INSTALLATION PRECAUTIONS

Care must be taken due to the propensity for HV flashovers and insulation breakdown due to CDI ignition characteristics.

It is important to fully read and understand these instructions and have a good knowledge of automotive electrical systems before commencing installation.

IGNITION COILS

(IMS street systems only)

COIL SELECTION

Most inductive ignition coils will work reasonably well with CDI systems however for ultimate ignition energy and efficiency use a CDI specific coil such as the Haltech HT020132.

Use resistive spark plugs at all times!

Coils with inbuilt drivers are not suitable for use with CDI ignition, these can generally be identified by 4 or more electrical connections.

Keep plug gap ≤ 0.025 " (0.6mm) on boosted engines to prevent coil damage.

DO NOT use AEM pencil coils under any circumstances!

Do not use ferrite (Mercury) coils in parallel wired pairs!



High Output CDI Coil
Haltech Part Number: HT020132

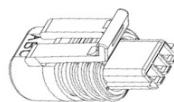
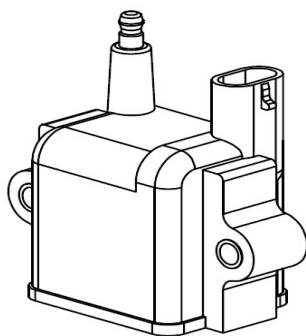

Pin A : CDI Negative (-)
Pin B : CDI Positive (+)
Pin C : Ground (To Cylinder Head)

ECU Ignition Setup

Ignition Edge: Falling (M&W), Rising (MSD)
Dwell Mode : Constant Charge
Dwell Time: 2ms

Wiring instructions are for Haltech and M&W Ignition systems. If connecting to an MSD CDI reverse pins A and B to maintain correct spark plug polarity

CAUTION!

**IGNITION COIL DAMAGE MAY OCCUR IF
OPERATED WITH AN EXCESSIVE SPARK GAP**



DISCONNECT POWER BEFORE WORKING ON UNIT

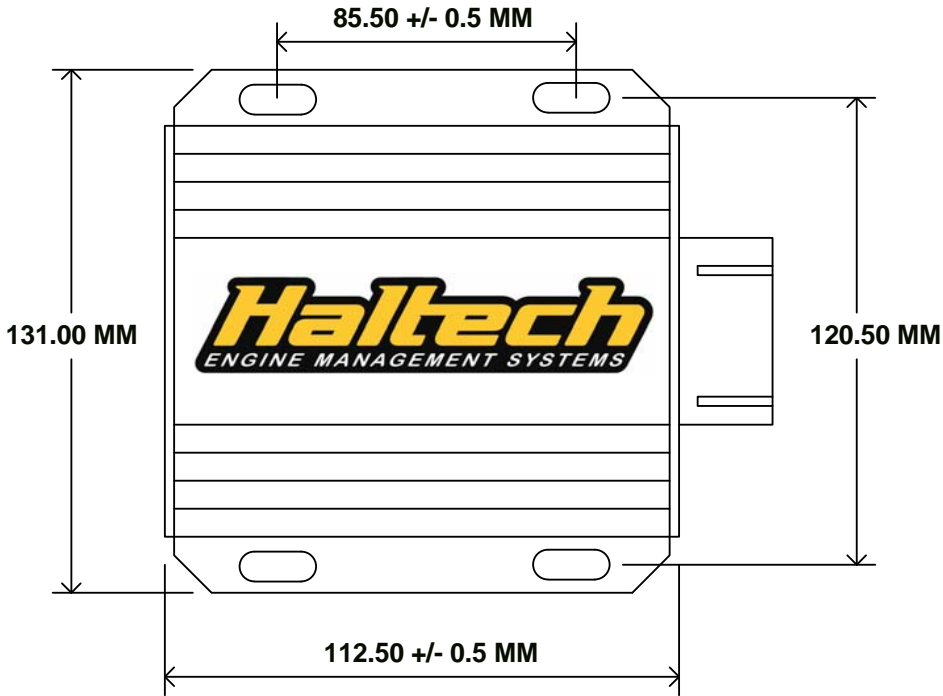

Slot dimensions - 5mm * 10mm

Title			MOUNTING DIMENSIONS		
Size	Number	Revision			
A4	(C) M&W Ignitions	23.06.14.1			
Date:	23-Jun-2014	Sheet 1 of	1		
File:	D:\M&W\...\Mounting dimensions.sch	Drawn By:	M&W		



DISCONNECT POWER BEFORE WORKING ON UNIT



VIEWED FROM BACK OF CONNECTOR

KEEP ALL INPUTS WELL SEPARATED FROM COIL OUTPUTS

1 +12V (Battery)	7 Ground (Battery)	13 ECU IGN1
2 +12V (Battery)	8 Ground (Battery)	14
3 Self test	9	15 ECU IGN2
4	10	16 Ignition switch
5 Coil 3 +	11 Coil 2 +	17 Coil 3 & 4 -
6 Coil 1 +	12 Coil 4 +	18 Coil 1 & 2 -

SPECIFICATIONS

Supply voltage = 13V - 18V DC negative ground
 Startup voltage = 6V
 Maximum supply current = 7.0A
 Power off current < 700uA
 Maximum ignition frequency = 1,200Hz
 Maximum energy limit = 700Hz/550 Hz
 Coil primary voltage = 460V/540V
 Spark energy = 115/150 millijoules
 Trigger = Haltech IMS protocol
 Maximum temperature = 85°C
 Dimensions = 112L * 110W * 40H
 Weight = 570gm

Title			HALTECH 4 CHANNEL IMS CDI		
Size	Number		Revision		
A4	(C) M&W Ignitions		31.07.14.1		
Date:	31-Jul-2014		Sheet 1 of 1		
File:	D:\M&W\...\IMS4_S3_1.sch		Drawn By: M&W		

Haltech

ENGINE MANAGEMENT SYSTEMS

CAUTION!
HIGH VOLTAGE



DISCONNECT POWER BEFORE WORKING ON UNIT

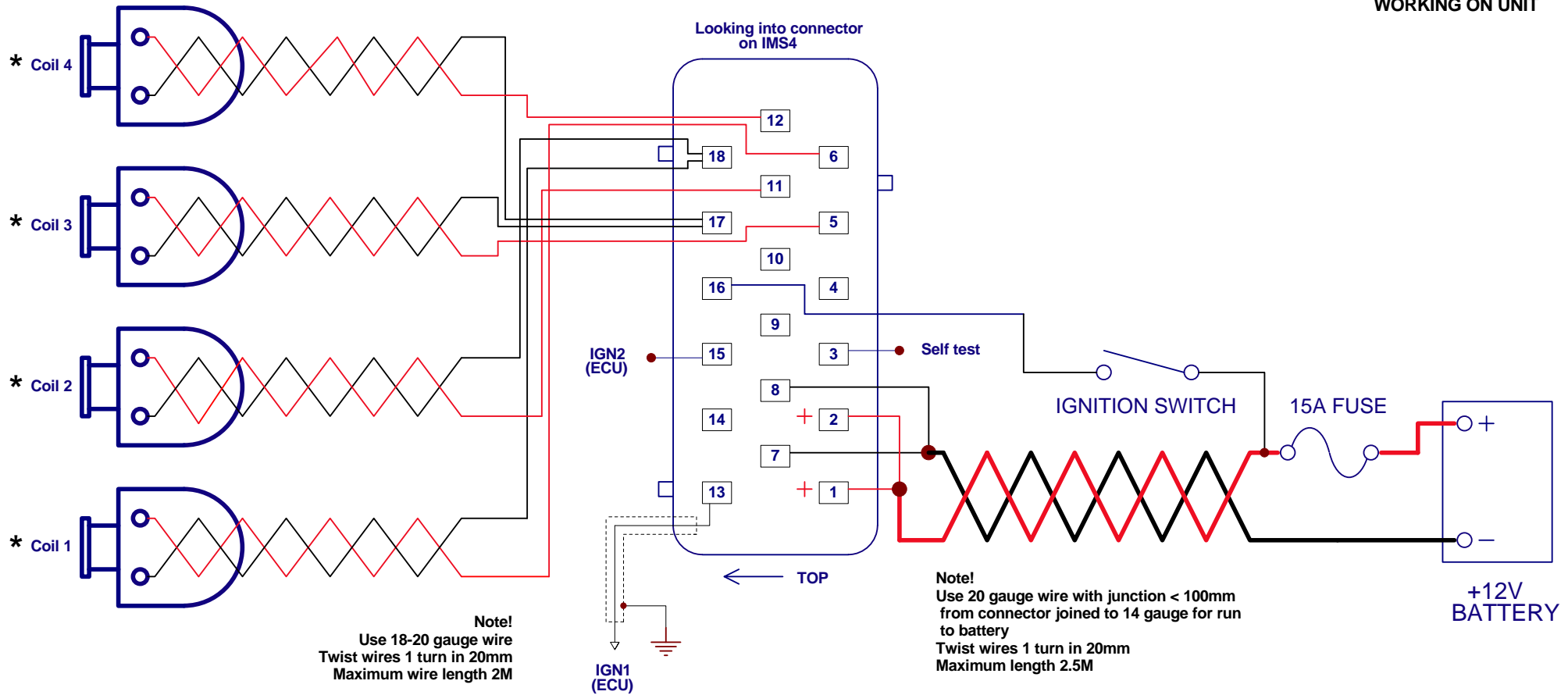

* Cylinder number not firing order!

Title			HALTECH 4 CHANNEL IMS CDI		
Size	Number	(C) M&W Ignitions		Revision	05.08.14.1
A4					
Date:	5-Aug-2014	Sheet 1 of			
File:	D:\M&W\...IMS4_S3_2.sch	Drawn By:		M&W	



DISCONNECT POWER BEFORE WORKING ON UNIT

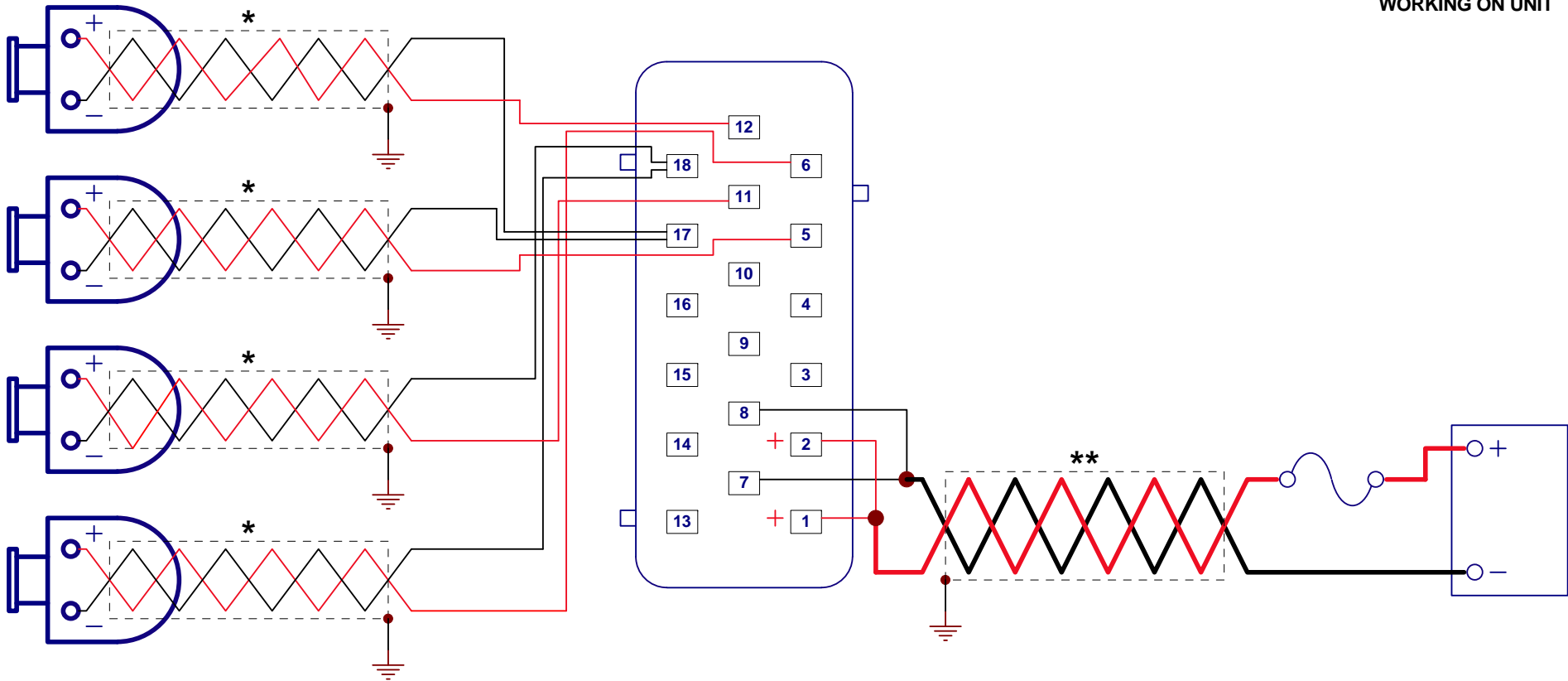

- * Use twisted shielded cable grounded at one end only
- ** Shielded power cables required for Australian EMC compliance

Title			SHIELDING & EMC COMPLIANCE		
Size	Number			Revision	
A4	(C) M&W Ignitions			23.06.14.1	
Date:	23-Jun-2014	Sheet 1 of	1		
File:	D:\M&W\...\EMC.sch	Drawn By:	M&W		