



NTK2000 UEGO OPERATORS MANUAL

CONTENTS

Introduction	page 1
Uego Sensor	page3
Installation.....	page4
Operation	page5
Software	page6
M&W LCD	page9
Kit Components	page10
Output Graphs	page11
Specifications	page16
Wiring Diagrams	page17

M&W Ignitions

6 Horning Street
Kurnell 2231
Sydney
Australia

Ph +61 2 96688481
Fax +61 2 96688209

email: sales@mwignitions.com

Copyright Notice

M&W Ignitions is the owner of Copyright in this publication, including layouts, drawings, text and part numbering systems. This publication must not be reproduced in whole or in part without written authorisation from M&W Ignitions.

Publication Release 1.1

www.mwignitions.com



INTRODUCTION



The M&W NTK2000 Uego system uses a **Universal Exhaust Gas Oxygen** sensor and this works completely differently from a normal oxygen sensor you would find in your car. It allows precise measurement over a wide AFR range.

UEGO sensor systems are used by all original equipment manufacturers for ECU mapping and are also widely used in motorsports including F1.

The microprocessor controlled M&W Uego controller features a fully **linearized real time 0 to 5 volt analog output** giving 10 to 20/1 air fuel ratio.

This simple scaling allows easy input into data acquisition systems and engine management systems. 12V operation with a cigarette lighter plug allows easy fitment for vehicle testing.

The RS232 port allows connection to IBM compatible computers and laptops with DOS, Windows 95/98/NT/2000/XPM&W multimode LCD with AFR

& Lambda modes

LARGE CHARACTER MODENORMAL GRAPH

MODEZOOMED RICH SIDE GRAPH MODEWindscreen mount option available and PocketPC software available. The controller uses a **true wide range** NGK sensor which when used with the tail pipe probe adapter provides a very versatile tuning tool for engine mapping and diagnostic purposes.



INTRODUCTION

Output configurations

0-5V analog output and RS232 provide common interface options.

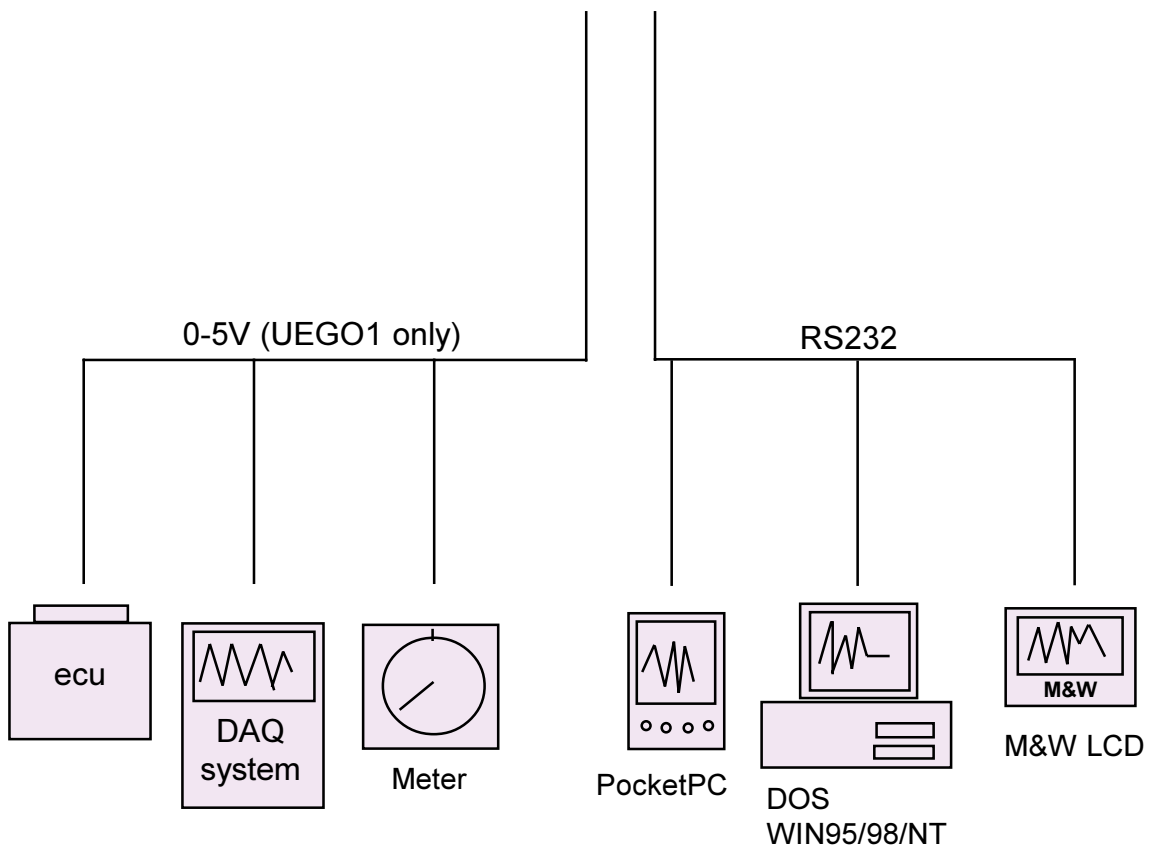

UEGO SENSOR

The wide range sensor

The sensor uses a special pumping cell which gives a current output depending on the air fuel ratio. This is completely different to a “normal” oxygen sensor. The pumping cell design allows measurement of air fuel ratios over the whole range whereas a “normal” oxygen sensor is only capable of measuring a small range either side of 14.7/1 air fuel ratio. Each wide range sensor is calibrated and supplied with a calibration chip which can be easily changed should a replacement sensor be required.

Note: the sensor contains a ceramic module and should not be subject to mechanical or thermal shock or it may be damaged.



Replacement Sensors

Each sensor is individually calibrated and comes with a calibration chip which can be easily changed by removing the controller end plate. The chip should be installed with the correct orientation as shown below.

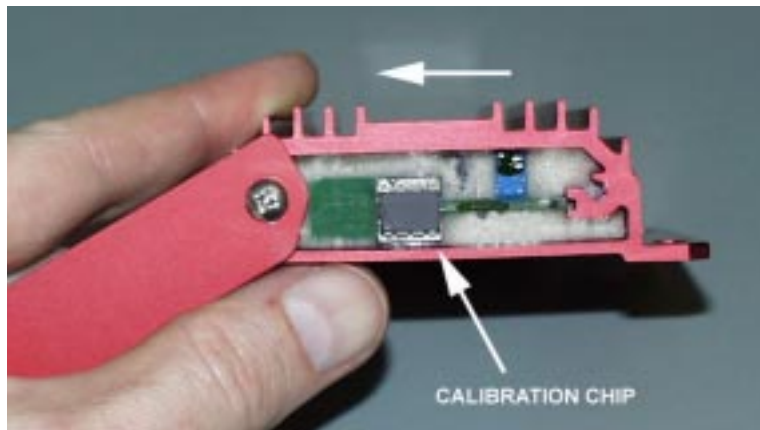

INSTALLATION

Sensor Placement

The sensor may be removed from the tailpipe probe and mounted in the exhaust system however for all general tuning this is not necessary unless you are installing the system in an engine Dyno cell. If the sensor is to be mounted in the exhaust there is no need to place the sensor in the actual exhaust manifold as the heater has enough capacity to warm the sensor to operating temperature.

The sensor should NOT be mounted in the exhaust manifold of a turbo charged engine. For turbo charged applications it must be installed after the turbo charger.

Normally the sensor should be mounted at least 1 metre from the cylinder head. Contact us for specific engine dyno installations. For emission's work the sensor may be mounted in the exhaust manifold factory position (normally aspirated only) however the sensor must not exceed 800°C for any length of time.

For installations using the analog 0-5V output to connect to other devices such as DAQ systems, ECU's and other measuring devices the dyno/hardwired wiring harness should be used as this separates the sensor heater ground to eliminate ground loops.

Note: however if you have a differential input available on your measuring device the lighter socket wiring harness could still be used.

If used in an engine dyno a suitable regulated +13.8V DC 3A supply must be provided.



Tail pipe probe has a simple clamp mounting. The cable may be installed through the rear hatch or window.



Windscreen mount option for LCD Display available

Pre-Post Catalyst Issues

Contrary to popular belief good results can be obtained post catalyst. For ECU mapping for emissions compliance and for monitoring of perturbation pre catalyst must be used. However for all general tuning post catalyst with the tailpipe probe works fine. Why is this so? For full load tuning the catalyst is overwhelmed and has no effect on the measurement. Also at part load the catalyst does react against the exhaust gases however the **balance** of these gases generally stays the same allowing the Uego to work correctly

OPERATION

- (1) Insert probe with Uego sensor into exhaust tail pipe.
- (2) Connect controller cable through back windows, hatch or trunk.
- (3) Connect to lighter socket.
- (4) Connect Meter, DAQ system, Laptop/PC, PocketPC or M&W LCD.
- (5) Power may now be applied.
- (6) Warm up cycle will take approx 30 seconds. During this time the laptop will display "WARMUP" and if the 0-5V is connected it will be at 2.5V.
- (7) After warmup the current AFR will be displayed and tuning can commence.

NOTE: Do not operate engine without power to controller when sensor is in the exhaust.

Tuning Recommendations

It is outside the scope of this document to describe correct tuning or engine mapping techniques however the following figures are offered as a guide:

Normally asperated engines at full load = 12.5 to 13.0 AFR

Turbo engines at full load = 11.0 to 12.5 AFR.

Cruise mixture both types = 14.0 to 14.7 AFR. (14.7 if closed loop operation)

Much can be learned by checking the manufactures settings as a starting point. The Uego is an ideal tool for such testing.

DO NOT

- (1) Do not operate the sensor with high lead content fuels as this may reduce the sensor life to 50 hours.
- (2) Avoid tuning in the rain with the tailpipe probe as this can cause excessive thermal shock to the sensor which may destroy the ceramic element. Also when tuning boats an influx of water into the exhaust will destroy the sensor if it is immersed.
- (3) Generally do not run the engine with the Uego installed without power applied to the controller.

Tuning Tips

Be aware that on small capacity engines when using the tailpipe probe with big exhausts (eg. turbocharged 4 cyl) it is not uncommon to get erratic measurements at idle. This is due to the small amount of exhaust gas available at idle. Also a strong wind can also affect this. When backing off the throttle while decelerating, erratic readings due to the same problem can be experienced.

SOFTWARE

DOS

System Requirements

286- on
VGA
1 X Serial port (Com1 only)

Installation

The EXE file can be run from the floppy or copied to the hard disk. This program is configured for COM1 port only.

Operation

Connect the UEGO serial cable to the COM1 port. Power up the UEGO and run the EXE the message "UEGO ONLINE" should appear in the top right hand corner of the screen. If not then the UEGO system is not powered or the serial cable is not connected to the correct serial port (most PC's have 2 serial ports also most laptops have 1 serial port and this is normally configured as COM1). If online the screen will display "WARMUP" for approximately 30 seconds and then the graph trace will begin. Lambda λ or Air Fuel Ratio display may be selected. The supply voltage is displayed if this goes below 12V the heater may not reach the correct temperature.



SOFTWARE

Windows 95/98/NT/2000/XP

System Requirements (Min)

486 DX2 50Mhz
VGA
1 X Serial port

Installation

The EXE file can be run from the floppy or copied to the hard disk. There are no DLL's or other files to install.

Operation

Connect the UEGO serial cable to the desired comm port (1 to 8). Power up the UEGO and run the EXE the "UEGO ONLINE" indicator should be green.
(Note: The software defaults to COM1 so if using a different port select it from the "SETUP" pull down menu.) If not then the UEGO system is not powered or the serial cable is not connected to the correct serial port (most PC's have 2 serial ports also most laptops have 1 serial port and this is normally configured as COM1). If online the screen will display "WARMUP" for approximately 30 seconds and then the graph trace will begin. Various fuel types and Lambda λ or Air Fuel Ratio display may be selected. The supply voltage is displayed if this goes below 12V the "Low volts" indicator will come on. This is because the heater may not reach the correct temperature at less than 12V.

Version 2.0 and later UegoGraph software allows logging to disk in CSV text format. The text file can then be loaded into a spreadsheet program such as Excel for analysis. The sample rate can be set to Normal (approx. 10 samples per second) or Fast (approx. 15+ samples per second depending on PC speed).

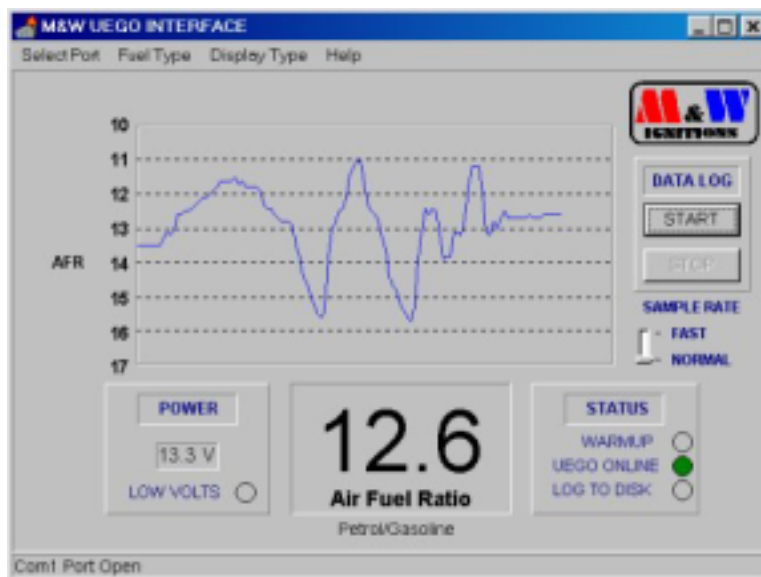

SOFTWARE

Pocket PC

System Requirements

Pocket PC

WinCE 3.0 (note: VB runtime module required for later WinCE versions)

1 X Serial port available with 9 pin connector.

Installation

Once the CAB file has been installed the UEGO icon should appear in the Programs Window.

Operation

Connect the UEGO serial cable to the serial port. Power up the UEGO and run UEGO.EXE if online the screen will display "WARMUP" for approximately 30 seconds and then the graph trace will begin. If "OFFLINE" is displayed then the UEGO system is not powered or the serial cable is not connected. Lambda λ or Air Fuel Ratio display may be selected. The supply voltage is displayed if this goes below 12V the heater may not reach the correct temperature.



M&W LCD DISPLAY

Connect the display's 9 pin connector to the Uego controller. Power is applied when the Uego controller has power. No other setup is necessary display will operate whenever controller is operating.



The display has 2 buttons on the end.

Contrast:

Hold down contrast button until a suitable LCD contrast is obtained.

Mode Select:

Mode select button allows the operator to select 1 of 6 modes. Press and hold the "mode select" button to advance to next display mode. Repeat to advance again.



NORMAL GRAPH MODE

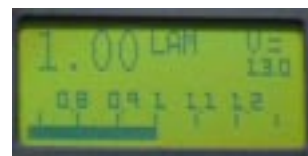

ZOOMED RICH SIDE GRAPH MODE

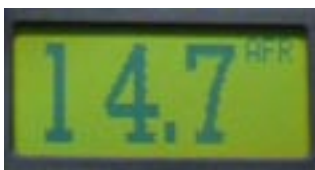

LARGE CHARACTER MODE



NTK2000 UEGO KIT COMPONENTS

NTK2000 UEGO Kit contains:

- 1 X NTK2000 Uego controller .
- 1 X main wiring harness with lighter plug.
- 1 X RS232 cable.
- 1 X stainless steel tail pipe probe.
- 1 X NTK UEGO sensor.
- 1 X mini CD with PDF manual and PC software (95/98/NT/XP/DOS & PocketPC).
- 1 X aluminium carry case.



(NOTE: Multimode LCD shown in picture is an optional)



M&W Uego Controller Analog Output

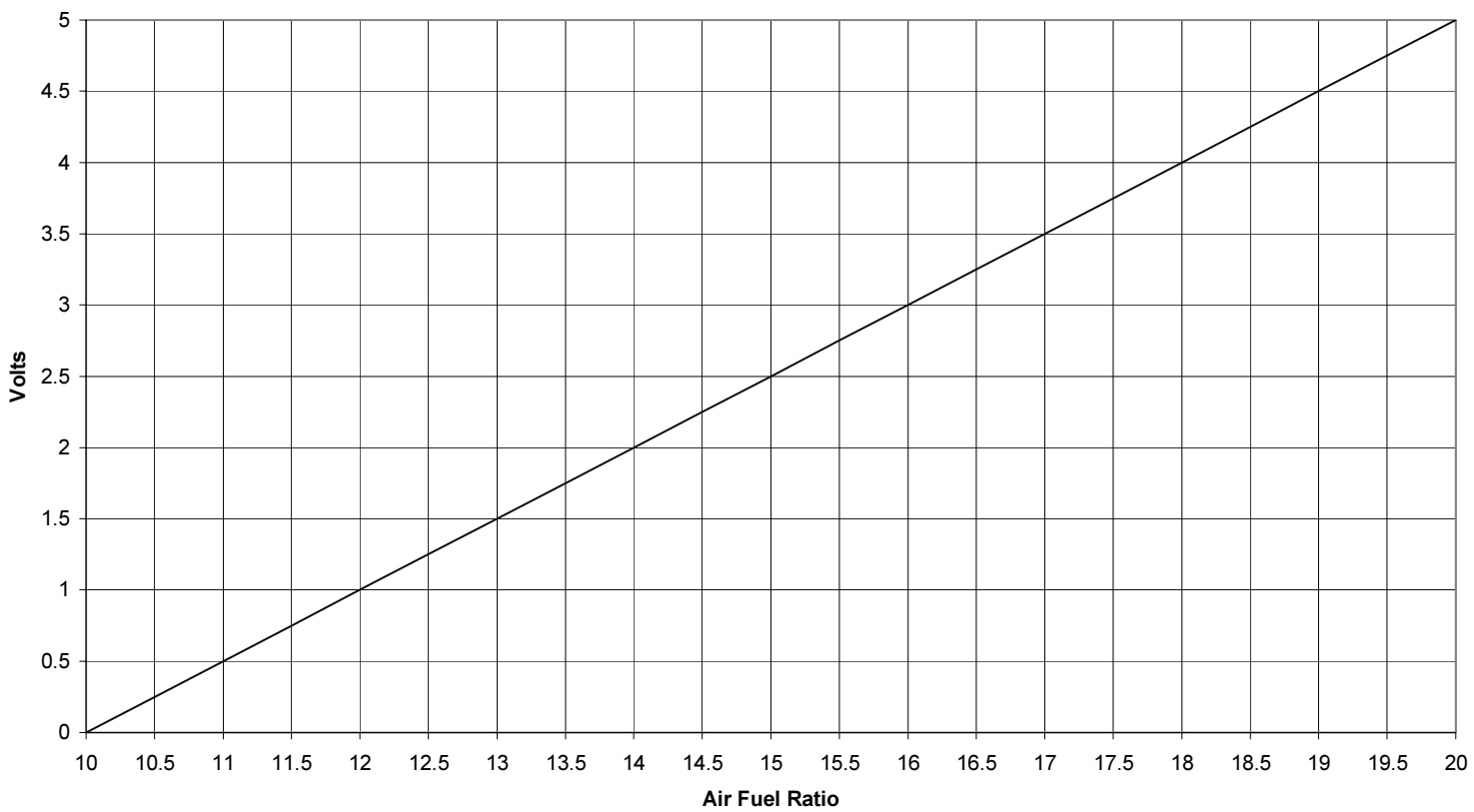

Output Scaling

$$\text{AFR} = (\text{volts} \times 2) + 10$$



Lambda Chart for Petrol (Gasoline)

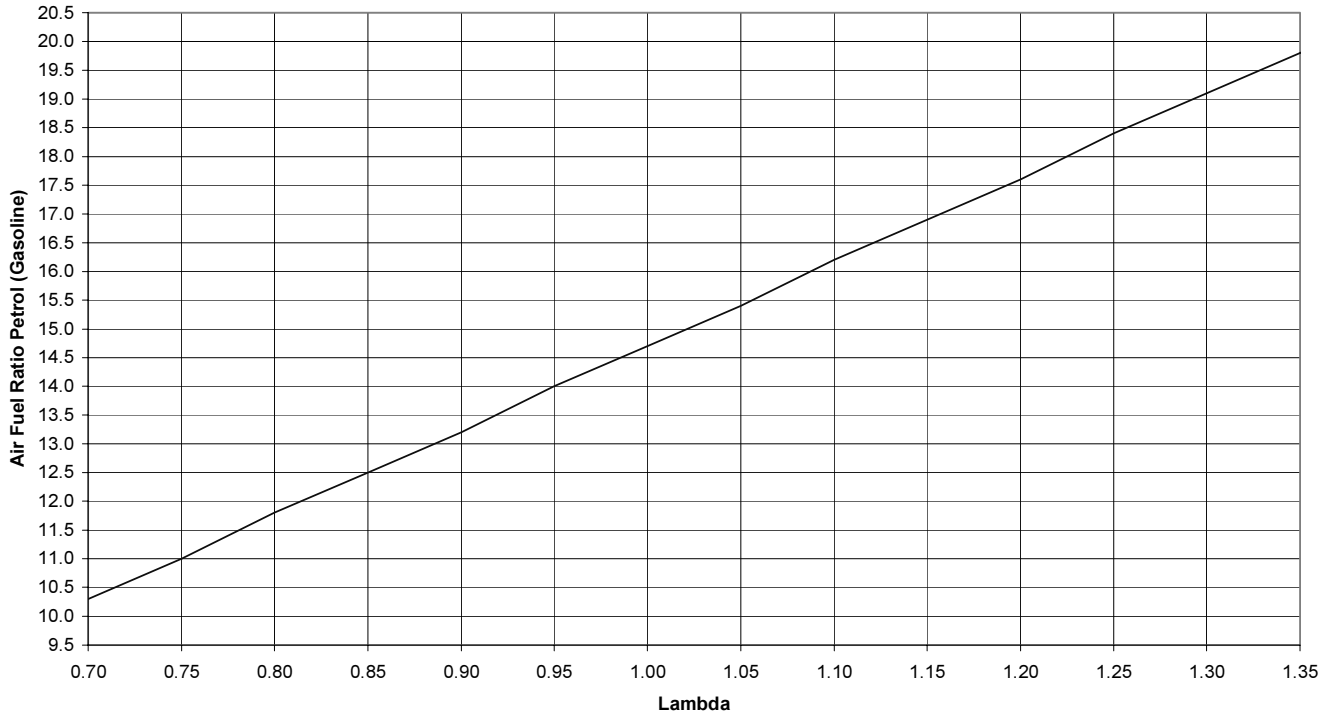

Lambda Chart for Alcohol

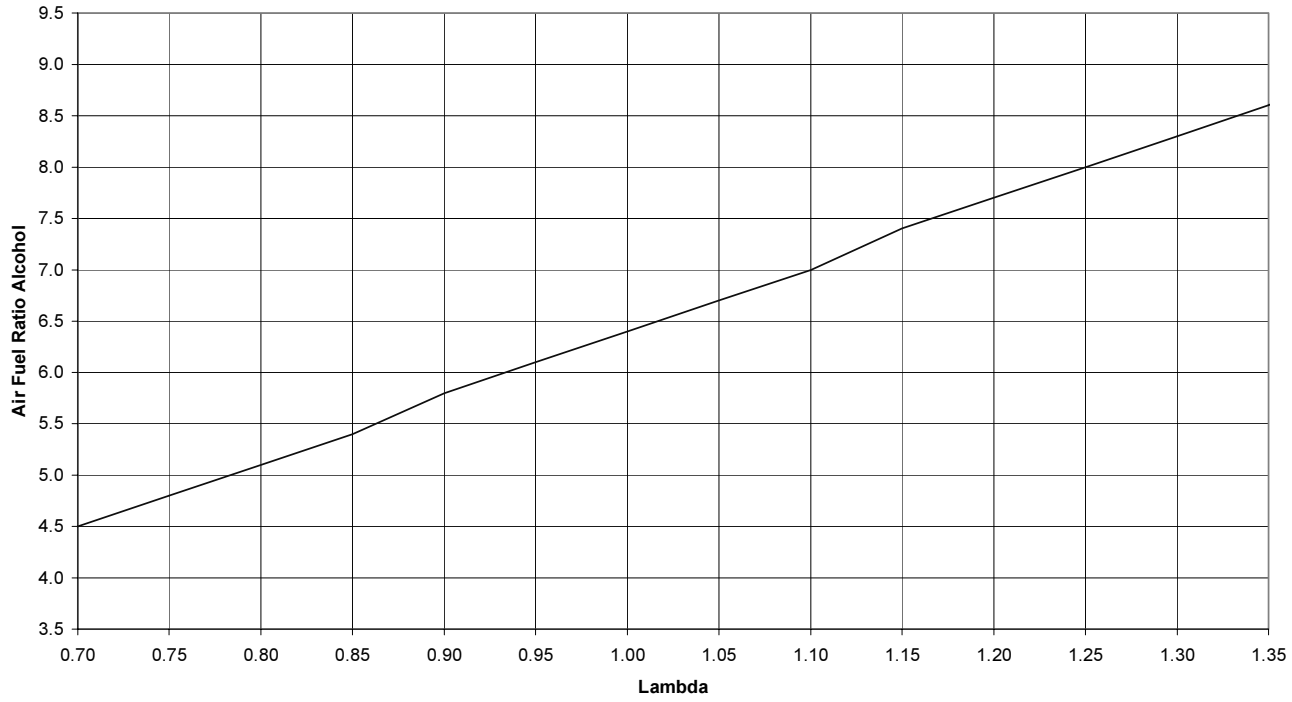

Lambda Chart for LPG (Propane)

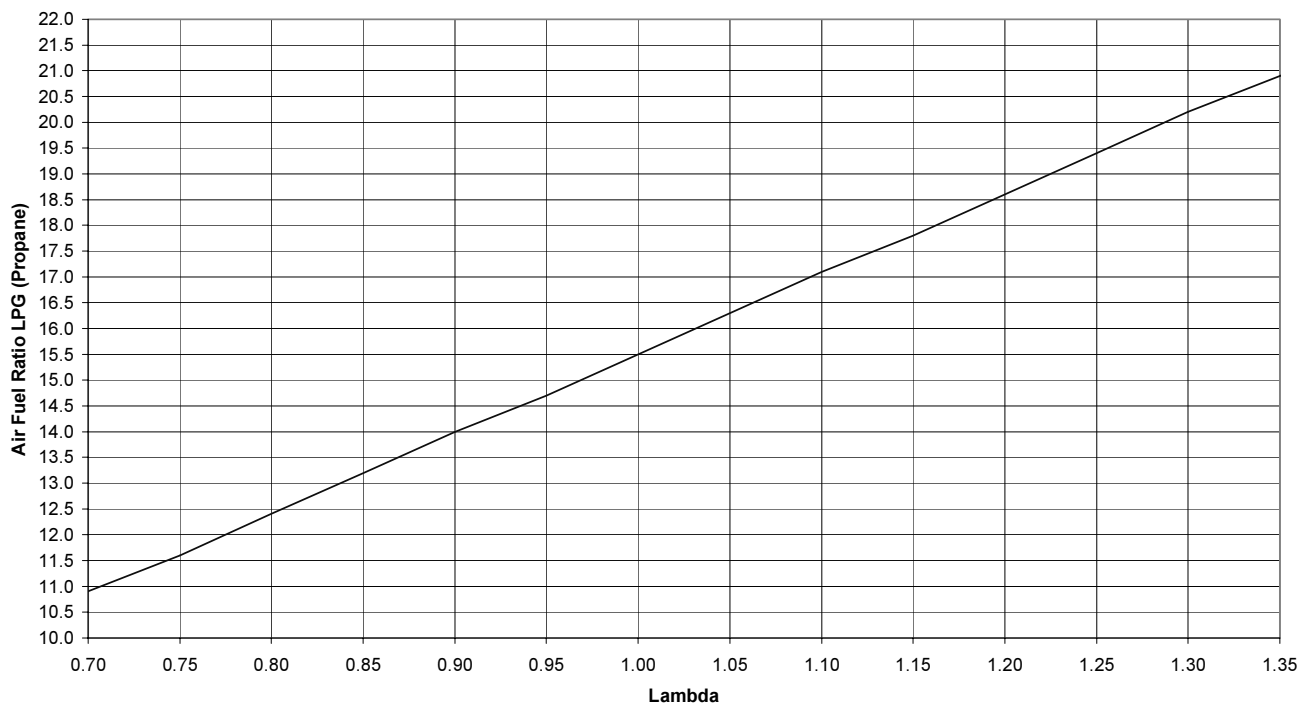



Lambda Chart for Diesel

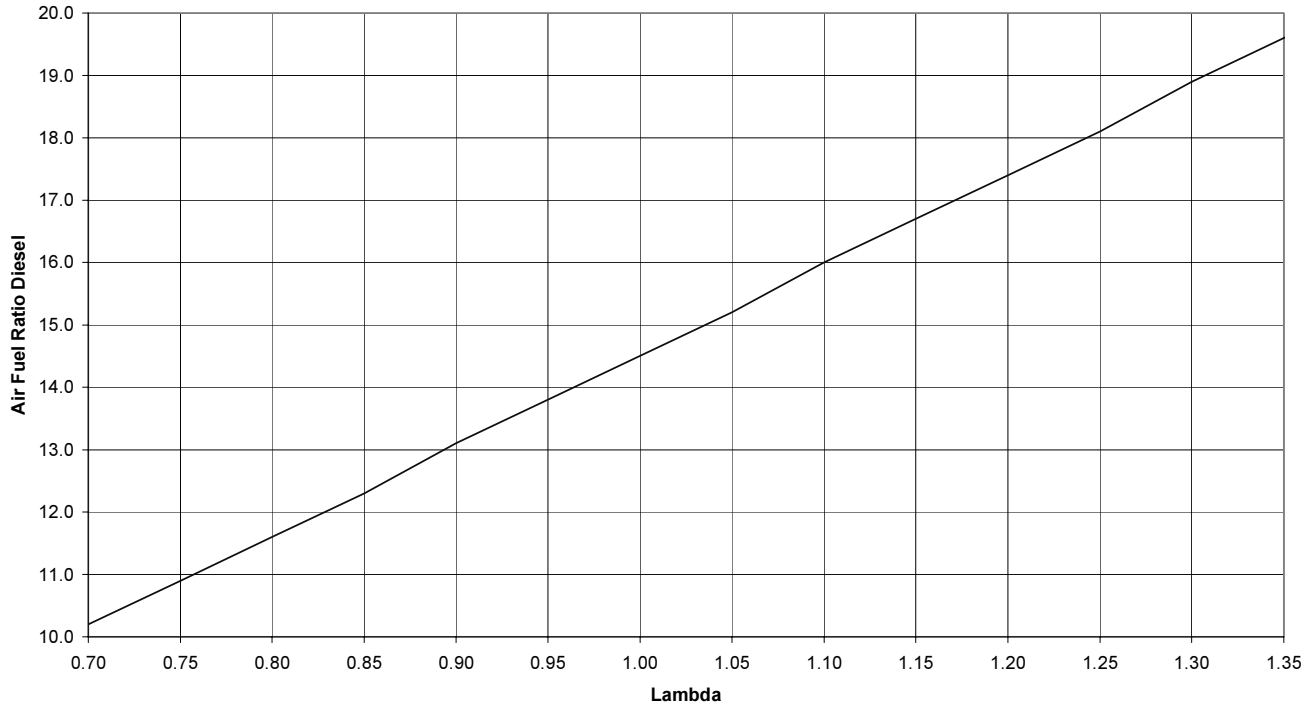

SPECIFICATIONS

CONTROLLER

Processor:

8 bit with Eeprom calibration chip

Supply voltage:

12 to 15 volts DC (negative ground only), 200mA (controller only).

Weight:

330 grams

Dimensions:

Width 88mm

Length 105mm

Height 27mm

Inputs:

1 X Uego sensor

1 X supply voltage (internal)

Outputs:

1 X RS232 port

1 X 8 bit DAC 0-5 volt DC analog output

Measuring range:

10 to 20/1 air fuel ratio (petrol/gasoline)



SENSOR

Type:

NGK L1H1 or L2H2 wide range 5 wire sensor. (Exhaust temperature should not exceed 800°C)

Warmup time:

approx 30 seconds @ 25°C ambient

Weight:

85 grams

Heater Current:

1.5A at 12.8V approx. warm

Note: 12V min recommended

Mounting:

M18 X 1.5 thread



NOTE: sensor is not rated for continuous operation on high lead content fuels. Operation in this mode may limit sensor life to approximately 50 hours.

System accuracy:

+/- 0.15 @ 10:1 AFR, +/- 0.025 @ 14.7 AFR, +/- 0.25 @ 20:1 AFR

Controller Repeatability:

+/- 0.01 10-20:1 AFR



Note: 5A fuse in lighter plug

M & W IGNITIONS

(C) 2002 M&W IGNITIONS

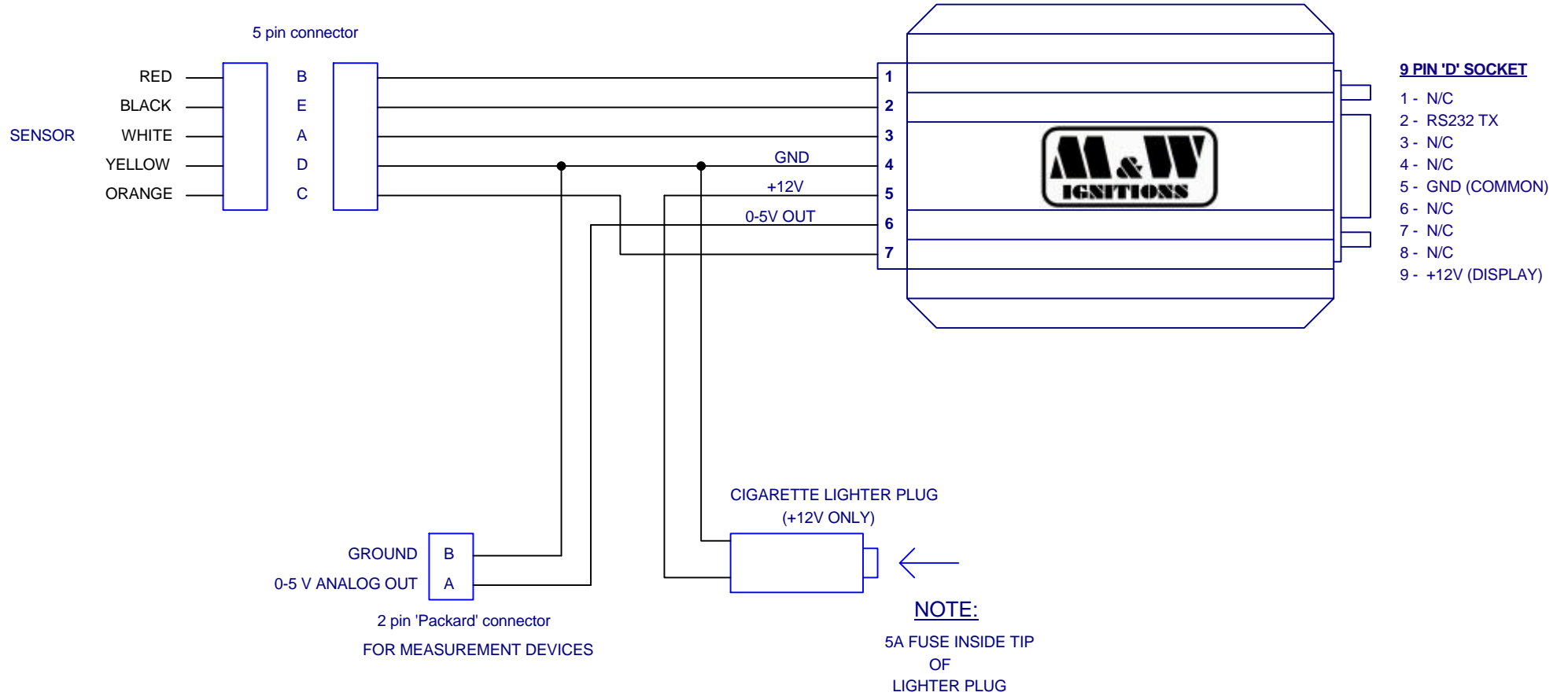

Title				NTK2000 UEGO HARNESS			
Size	Number			Revision			
A4	TYPE 3			1.2			
Date:	6-Sep-2004			Sheet 1 of 1			
File:	C:\M&W\UEGO Harness Type 3.sch			Drawn By:		M&W	

RECOMMENDED UEGO WIRING FOR HARD WIRED SYSTEMS SUCH AS DYNAMOMETER OR RACE CAR.

UEGO SENSOR WIRING

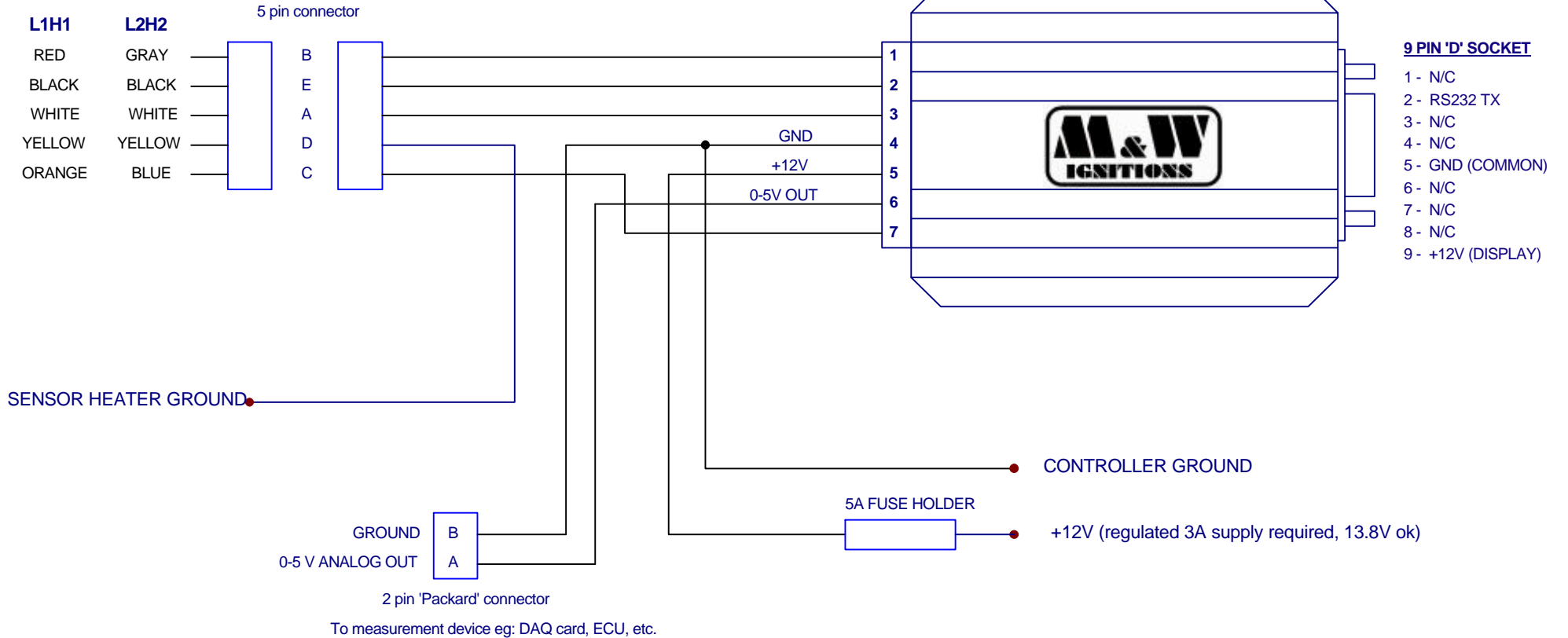

NOTE: To reduce ground loop errors when using equipment with non-differential inputs the heater ground wire and controller ground should be connected to ground separately as shown.

Title			NTK2000 UEGO HARNESS		
Size	Number	Revision			
A4	NTK2000 DYNO HARNESS	1.1			
Date:	14-Sep-2007	Sheet 1 of	1		
File:	C:\M&W\...\NTK2000 Harness Dyno.sch	Drawn By:	M&W		