



Pro-16

115/150mJ S3

ELECTRICAL WIRING & OPERATING INSTRUCTIONS

Applicable
S/No's 38xxxx

**FAILURE TO FOLLOW INSTRUCTIONS
WILL VOID WARRANTY**

CONTENTS:

2. Installation notes
6. Connections and specifications
7. Mazda 3 rotor
8. 6 cylinder direct fire
9. Mounting dimensions

Scan to download
current instructions



INSTALLATION NOTES

(Pro-Street Series 3 systems)

MOUNTING

Mount the unit in a dry location away from intense heat and ensure bottom condensation slots are unobstructed and oriented to permit gravity drain.

Failure to use supplied rubber mounts will void warranty!

IGNITION LEADS

Use inductively suppressed spiral wound metal conductor ignition leads.

Do not use carbon core or unsuppressed metal leads!

SPARK PLUGS

Non resistor spark plugs will greatly enhance ignition performance however some installations will require the use of resistor spark plugs for correct ECU operation.

When using resistor spark plugs it is imperative to check internal resistance as part of regular maintenance!

Open circuit or high resistance may cause damage to spark plug wires, ignition coils and CDI.

Fixed gap surface discharge and semi surface discharge spark plugs are only suitable for naturally aspirated applications.

Keep spark plug gap ≤ 0.025 " (0.6mm) for boosted motors to prevent coil and CDI damage!

INSULATION PRECAUTIONS

Degrease sparkplug insulators, sparkplug boots, ignition coil boots and installation tooling to prevent insulation breakdown.

Use of dielectric grease on sparkplug insulators and inside sparkplug and ignition coil boots will aid installation/removal and help prevent high voltage flashover.

POWER SUPPLY

Do not use voltage boosters, if the vehicle contains a PDM use it only to control CDI switch wire.

Connect ignition supply wires directly to battery!

When using a total loss electrical system install either a 16V or 18V battery to ensure adequate voltage and isolate when charging.

WIRING

If required power/ground wire length exceeds recommendations use paired battery cable (power and ground) to make up distance. Do not rely on vehicle chassis to provide ground path.

Use twisted pair wire for all power and coil connections. For improved noise suppression or to comply with EMC requirements use twisted shielded wire similar to M27500 series.

M&W CDI systems will open circuit the external fuse if over voltage conditions are experienced. Faults such as loose battery terminals/wiring or defective alternator/regulator may also cause this to occur.

Main connector pins are designed for roll crimping. Squeeze crimping or soldering will distort pins resulting in misfiring or incorrect CDI operation. Use of dielectric grease in main connector may reduce water ingress.

Common coil negative wires must be joined at or in the cdi connector.

Keep coil primary wires well separated from HT leads, coil HV outlet, coil body and any ECU wiring!

TRIGGERING

For correct operation trigger voltage relative to CDI ground must rise above 3.2V and fall below 1.6V.

M&W CDI systems default to falling (negative) edge trigger. To select rising edge (positive) trigger ground 'Trigger Edge' pin.

If uncertain lock Ecu timing and monitor engine with timing light while varying RPM. Timing should appear stationary with correct trigger edge.

Trigger input & coil output letters (or numbers) indicate CDI firing sequence not cylinder number unless otherwise stated.

POWER LEVEL SWITCH

Some M&W Pro street systems are provided with a (active low) power level switch. Do not manually activate this feature or operate continuously as this will significantly increase spark plug wear and system current draw. Activate by grounding input through either a 'Hobbs' style manifold pressure switch or programmable output from the ECU when elevated energy levels are required.

Additional ignition energy may cause an increase in electrical noise!

TWO SPARK SWITCH

Some M&W Pro street systems are provided with a two spark switch. Do not manually activate this feature as it will significantly increase spark plug wear and double system current draw. Activate by grounding the input through a programmable ECU output. Hi power and Two spark can not be used simultaneously!

TUNING

CDI performance is not affected by changes in dwell settings!

M&W CDI systems may reduce ignition delay requiring a reduction in timing. The resulting changes in combustion characteristics may also require alterations to fuel flow.

Always set ECU ignition delay to zero and re-tune both fuel and timing curves after installation!

TACHO OUTPUT

Tacho output provides a 50% duty cycle square wave signal approximately 1V below supply voltage. This will work with most aftermarket digital tacho's however some earlier types and those designed for coil negative triggering may not read accurately and require an adaptor.

LED INDICATOR

After applying power to input switch wire the LED will illuminate for approximately 1 second then extinguish. It will then flash briefly with each consecutive trigger event received.

A repeated double flash of the LED may indicate a possible faulty ignition coil, faulty wiring, low supply voltage or damage to the CDI.

TESTING

The CDI may be tested by momentarily grounding the trigger inputs which will cause the LED to flash and corresponding ignition coil to spark.

Do not conduct this test without grounded spark plugs installed!

IGNITION COIL SELECTION

For ultimate ignition energy use coils specifically designed for CDI use such as the M&W #COI006. Ignition coils primarily designed for inductive ignition will significantly limit CDI output.

Wire inductive coils reverse polarity when used with M&W CDI's.

Do not use AEM pencil coils or Prufex brand ferrite coils under any circumstances!

COP COILS

Many COP (coil on plug) coils are unsuitable for CDI use and will break down damaging the ignition system. Some COP coils designed for inductive ignition may also contain a HV blocking diode in the secondary winding.

Use resistive sparkplugs with all COP coils and keep plug gap < 0.020" (0.5mm) to prevent coil & ignition damage.

FERRITE CDI COILS

Ferrite core cdi coils emit high levels of EMI requiring additional shielding practices and are unsuitable for use with alcohol based fuels.

Do not use ferrite coils wired in parallel pairs!

M & W IGNITIONS

Performance & Quality since 1996

VIEWED FROM BACK OF CONNECTOR



1 +12V (Battery)	7 Ground (Battery)	13 (P) Power level input
2 +12V (Battery)	8 Ground (Battery)	14 Trigger input
3 Trigger input	9 Edge selection	15 Trigger input
4 (T) Tacho output	10 Edge ground	16 Ignition switch
5 COIL +	11 COIL +	17 COIL -
6 COIL +	12	18 COIL -

SPECIFICATIONS

Operating voltage	12.5V -> 18V DC
Polarity	Negative ground
Startup voltage	>= 6V
Maximum supply current	7.0A (per box)
Power off current	< 700uA (per box)
Maximum ignition frequency (combined)	2,400Hz
Energy limit (2st & rotary):	
Standard power	14,000 RPM
Hi power	11,000 RPM
Coil primary voltage:	
Standard power	460V
Hi power	540V
Spark energy:	
Standard power	115mJ
Hi power	150mJ
Trigger:	
Current	10mA
Edge	Adjustable
Voltage rsing	>= 3.2V
Voltage falling	<= 1.6V
Tacho output:	
Voltage	Supply - 1.2V
Output current	100mA
Shape	Square wave
Operating temperature	<= 105°C
Dimensions	112L * 110W * 40H
Weight	570gm (per box)

Title			PRO-16 SERIES 3
Size	Number	Revision	
A4	(C) M&W Ignitions	20.12.20.1	
Date:	20-Dec-2020	Sheet 1 of	1
File:	D:\M&W\...\Mazda 3 rotor 1.sch	Drawn By:	M&W

Wire Specifications

POWER SUPPLY:

Use 14ga wire from battery bifurcated into 20ga wire <= 100mm from connector. Junction is best achieved using a Solistrand or similar butt splice / barrel crimp. Maximum recommended wire length is 2M

IGNITION COILS:

Use 20ga wire from cdi to coils and keep as one continuous length. Maximum recommended wire length is 2M

Read installation guide for important wiring details!

M & W IGNITIONS

Performance & Quality

**CAUTION!
HIGH VOLTAGE**



**DISCONNECT POWER BEFORE
WORKING ON UNIT**

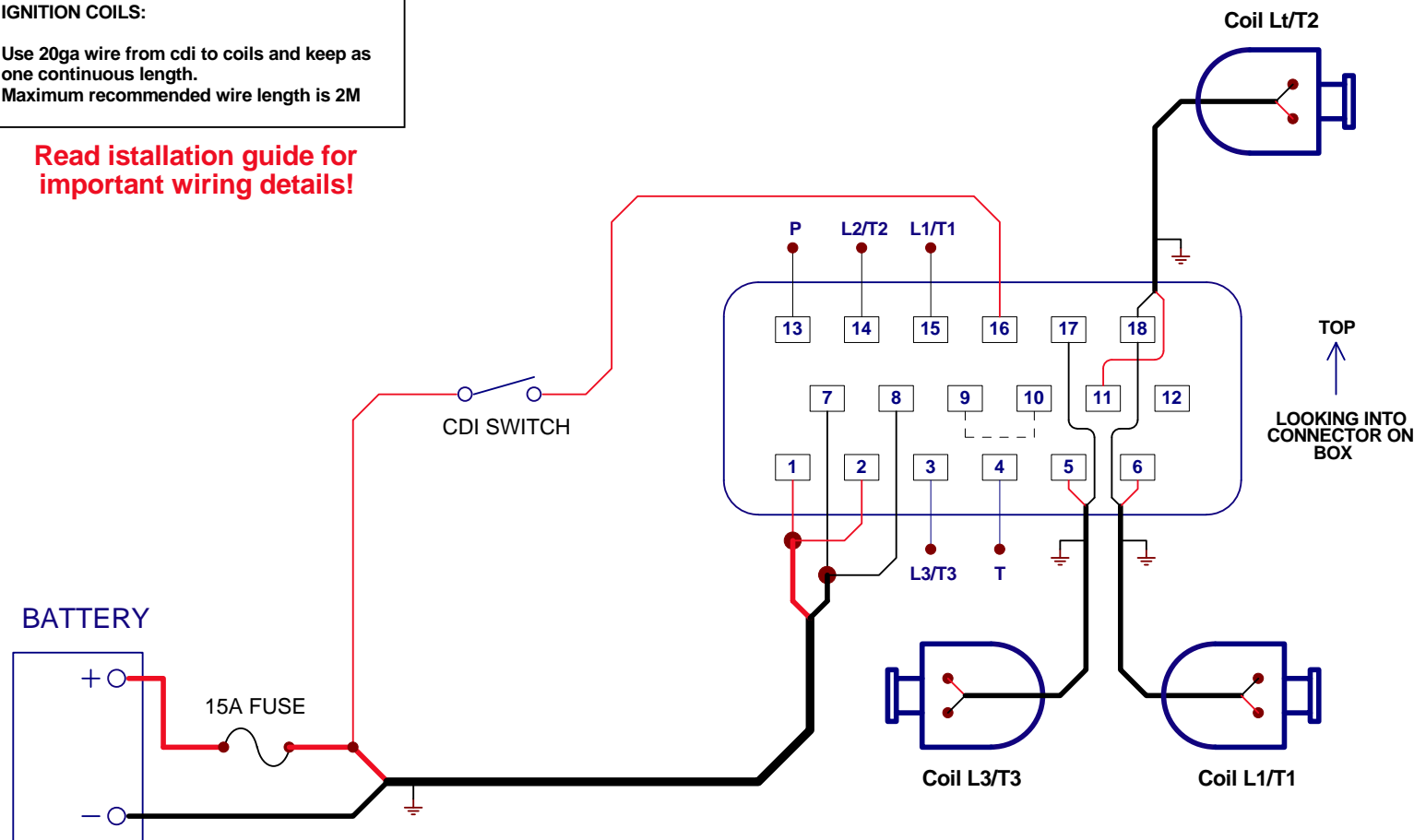

↑ TOP
LOOKING INTO
CONNECTOR ON
BOX

Note!

One box used for leading sparkplugs and the other for trailing

Title			MAZDA 3 ROTOR DIRECT FIRE
Size	Number	Revision	
A4	(C) M&W Ignitions	02.07.19.1	
Date:	3-Jul-2019	Sheet 1 of 1	
File:	D:\M&W\...Mazda 3 rotor.sch	Drawn By:	WAG

Wire Specifications

POWER SUPPLY:

Use 14ga wire from battery bifurcated into 20ga wire <= 100mm from connector. Junction is best achieved using a Solistrand or similar butt splice / barrel crimp. Maximum recommended wire length is 2M

IGNITION COILS:

Use 20ga wire from cdi to coils and keep as one continuous length. Maximum recommended wire length is 2M

Read installation guide for important wiring details!

M & W IGNITIONS

Performance & Quality

**CAUTION!
HIGH VOLTAGE**



**DISCONNECT POWER BEFORE
WORKING ON UNIT**

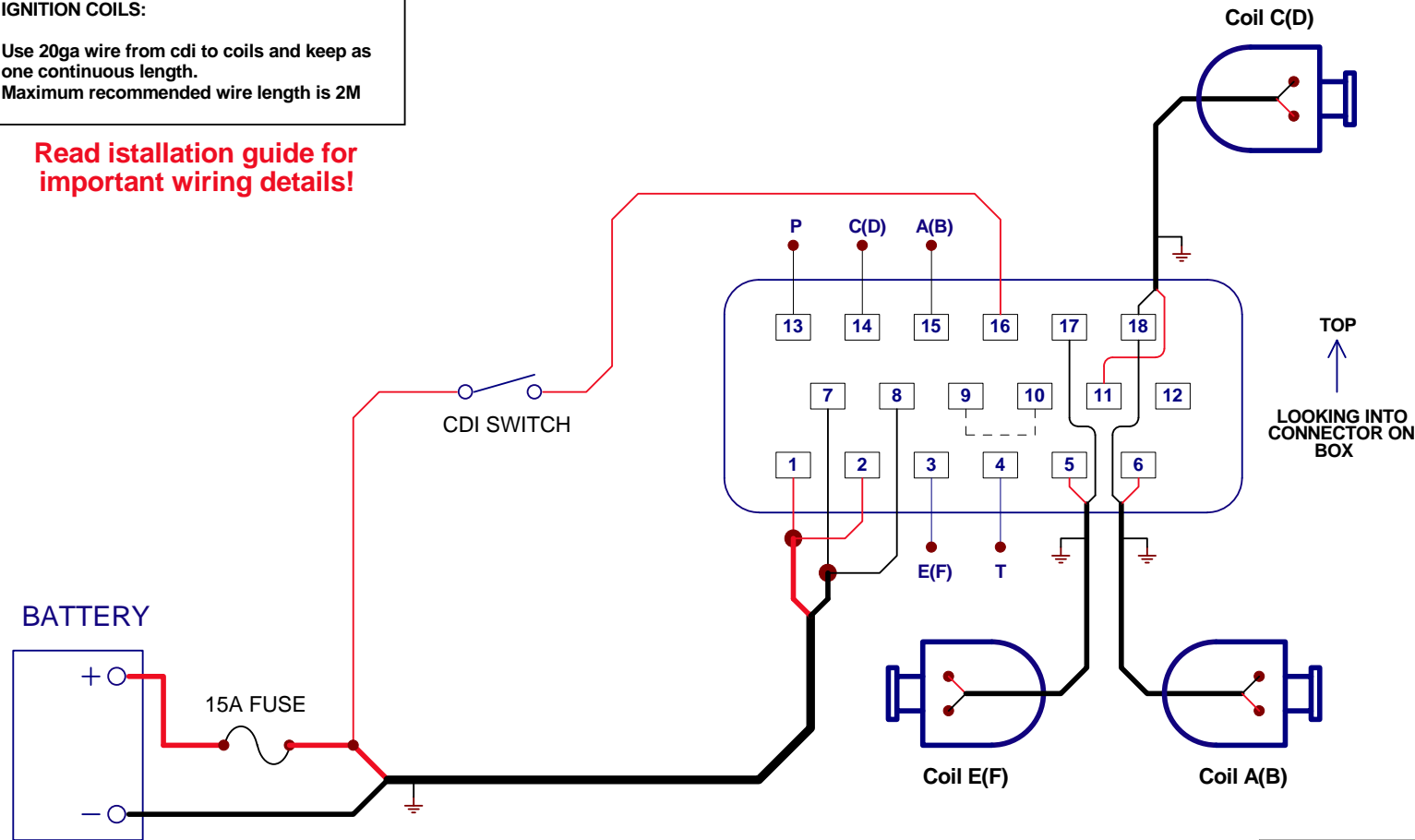

↑ TOP
LOOKING INTO
CONNECTOR ON
BOX

Note!

CDI firing sequence must alternate between boxes

Title			6 CYLINDER DIRECT FIRE		
Size	Number	Revision			
A4	(C) M&W Ignitions	20.12.20.1			
Date:	20-Dec-2020	Sheet	1	of	1
File:	D:\M&W\16 cylinder.sch	Drawn By:	WAG		

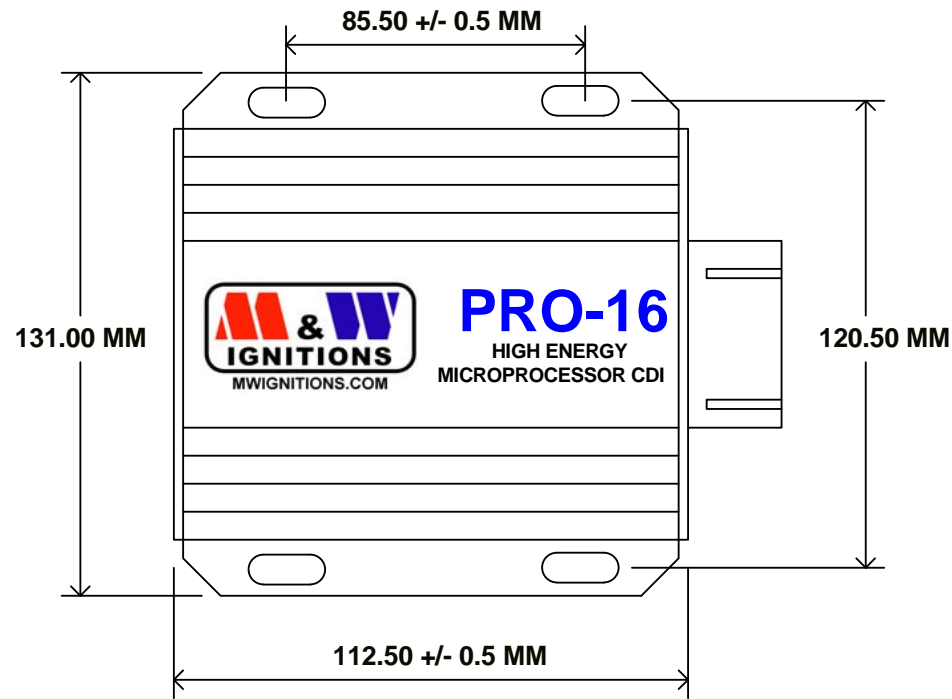

M & W IGNITIONS
 MWIGNITIONS.COM

PRO-16
 HIGH ENERGY
 MICROPROCESSOR CDI

Slot dimensions - 5mm * 10mm

Title			PRO-16 MOUNTING DIMENSIONS
Size	Number	Revision	
A4	(C) M&W Ignitions	02.07.19.1	
Date:	3-Jul-2019	Sheet 1 of 1	Drawn By: M&W
File:	D:\M&W\Pro16_S3 Mounting dimensions.dwg		