



Pro-Drag4R

2 Rotor 250mJ
Series 4

Applicable
S/No's 89xxxx

CONTENTS:

2. Installation & coil notes
6. Connections and specifications
7. 4 coil direct fire rotary diagram
8. Mounting dimensions

**CHECK WEBSITE FOR UP TO DATE INSTRUCTIONS
& ADDITIONAL INFORMATION**

INSTALLATION NOTES

(Pro-Drag 500mJ Series 4 systems)

It is essential to fully read and understand these instructions and have a comprehensive knowledge of automotive electrical systems before commencing installation!

MOUNTING

Failure to use supplied rubber mounts will void warranty!

Mount the unit in a dry location ensuring the bottom condensation slots are unobstructed and oriented to permit gravity drain. Select a location away from intense heat and if necessary provide a source of cooling air.

IGNITION LEADS

Do not use unsuppressed metal or carbon core ignition leads!

Use inductively suppressed spiral wound metal core ignition leads such as those available from Magnecor www.magnecor.com.

SPARK PLUGS

When using resistor spark plugs it is imperative to check the internal resistance as part of regular maintenance!

Open circuit or high resistance may cause failure of spark plug wires, ignition coils and CDI system.

The use of non resistor spark plugs will greatly enhance ignition energy however some installations will require the use of resistor spark plugs to eliminate electrical interference.

Fixed gap surface discharge and semi surface discharge plugs are only suitable for naturally aspirated applications.

Keep spark plug gap \leq 0.025" (0.6mm) to prevent coil and CDI damage!

INSULATION PRECAUTIONS

Ensure spark plug boots are a tight fit on the ceramic insulators!

Degrease spark plug ceramic, coil/plug boots and installation tooling to prevent insulation breakdown.

Use supplied dielectric grease on spark plug ceramic and inside coil/plug boots to significantly improve insulation properties and ease installation/removal.

POWER SUPPLY

**REVERSE POLARITY WILL CAUSE IRREPARABLE DAMAGE!
ALWAYS INSTALL EXTERNAL FUSE!**

Do not use voltage boosters or connect through a PDM.

When using a total loss electrical system install either a 16V or 18V battery to ensure adequate supply voltage and isolate when charging.

WIRING

Wire ignition system directly to battery!

If required wire length exceeds recommendations use paired battery cable (power/ground) to make up distance. Do not rely on vehicle chassis to provide ground path.

Use twisted shielded wire (similar to M27500) for all power and coil connections

M&W CDI systems will open circuit the external fuse under conditions of over voltage or reverse polarity. Faults such as loose battery terminals/wiring or a defective alternator/regulator may also cause for this to occur.

Main connector pins are designed to be roll crimped. Squeeze crimping or soldering will cause distortion resulting in misfiring or incorrect CDI operation. Use of dielectric grease in main connector may reduce water ingress.

Keep coil primary wires one continuous length and well separated from HT leads, coil HV towers and input wiring.

TRIGGERING

If CDI trigger edge and ECU ignition edge do not match timing will be erratic and vary with RPM!

For correct operation trigger voltage relative to CDI ground must rise above 3.2V and fall below 1.6V.

500mJ S4 Pro-Drag systems default to falling edge ignition. To select rising edge ignition install a jumper wire between 'Trigger edge' and 'Edge ground' input pins.

Where the ECU contains an inbuilt igniter it may be necessary to select rising edge ignition on the CDI.

Trigger input & coil output letters (or numbers) indicate CDI firing sequence not cylinder number.

Firing sequence must alternate between boxes in multi unit installations except 3/4 rotor Mazda where one box is used for leading spark plugs and the other for trailing spark plugs.

POWER LEVEL SWITCH

Do not manually or permanently activate this feature!

M&W 500mJ S4 ignition systems include a power level switch to reduce ignition energy under low engine load conditions.

Activate high power by grounding input through either a 'Hobbs' style manifold pressure switch or programmable output from the ECU when increased ignition energy is required.

TUNING

Always retune both fuel and timing curves after installing CDI!

CDI systems are edge triggered and not affected by changes in dwell settings. If uncertain set ECU dwell to 0.5mS.

M&W 500mJ S4 ignition may significantly reduce combustion delay requiring a reduction in ignition timing. The resulting changes in cylinder burn may also require alterations to fuel flow curves.

Set ECU ignition delay to zero and tune engine as required.

TACHO OUTPUT

The tacho output provides a 50% duty cycle square wave signal 1.2V below battery supply voltage. This will work with most aftermarket digital tacho's however earlier types and those designed for coil negative triggering may not read accurately.

LED INDICATOR

After applying power to switch wire both the red and green LED's will illuminate for approximately 1 second.

The green led will then extinguish and flash briefly with each trigger event received

The red led will stay on to indicate high power mode or extinguish for low power mode.

A repeated double flash of the red led may indicate a faulty ignition coil, faulty wiring, low supply voltage or damage to the CDI.

TESTING

Do not conduct this test without grounded spark plugs installed!

The CDI may be tested by momentarily grounding trigger inputs. This will cause the Green LED to momentarily flash and corresponding ignition coil to spark.

COIL SELECTION

Do not use 'Prufex' brand outboard motor coils or AEM pencil coils under any circumstances!

For ultimate performance use only high quality known brand ignition coils specifically designed for CDI use such as the M&W #COI006.

The use of multi purpose coils and those designed for inductive ignition will significantly reduce ignition performance.

C.O.P coils and coils with inbuilt igniters are not recommended for this ignition system and may fail damaging cdi system.

Ferrite core cdi coils are not recommended due to their short arc duration and high levels of EMI.

M & W IGNITIONS

Performance & Quality

CAUTION!
HIGH VOLTAGE



**DISCONNECT POWER BEFORE
WORKING ON UNIT**

VIEWED FROM BACK OF CONNECTOR



SPECIFICATIONS

Operating voltage	12.5V → 18V DC
Polarity	Negative ground
Startup voltage	>= 6V
Maximum supply current	25A
Power off current	< 700uA
Maximum ignition frequency	18,000 RPM
Energy limit:	
Single spark	15,000 RPM
Coil primary voltage:	
Low power	400V
High power	500V
Spark energy (per plug):	
Low power	160mJ
High power	250mJ
Trigger:	
Current	10mA
Edge	Adjustable
Voltage rising	>= 3.2V
Voltage falling	<= 1.6V
Tacho output:	
Voltage	Supply - 1.2V
Output current	100mA
Shape	Square wave
Operating temperature	<= 105°C
Dimensions	173L * 137W * 50H
Weight	1,030gm

1 +12V (Battery)	13 Ground (Battery)	25 Trigger L1
2 +12V (Battery)	14 Ground (Battery)	26 Ignition switch
3 +12V (Battery)	15 Ground (Battery)	27 Trigger L2
4 +12V (Battery)	16 Ground (Battery)	28 Trigger T1
5 Trigger edge	17 Edge ground	29 Trigger T2
6 Tacho (T)	18	30
7	19	31 Power (P)
8	20	32
9	21 Coil T2 -	33
10 Coil T1+	22 Coil T1 -	34 Coil T2 +
11	23 Coil L1 -	35
12 Coil L1 +	24 Coil L2 -	36 Coil L2 +

Title			PRO-DRAG4 ROTARY		
Size	Number	(C) M&W Ignitions		Revision	22.10.16.1
A4					
Date:	22-Oct-2016	Sheet	1	of	1
File:	D:\M&W\...\Pro-Drag4 Rotary S4 1.sch	Drawn By:	WAG		

Wire Specifications

POWER SUPPLY:

Use 12ga shielded wire from battery quadfurcated into 18ga wire <= 100mm from connector. Junction is best achieved using a Solistrand or similar butt splice / barrel crimp.

Maximum recommended wire length is 2M

IGNITION COILS:

Use 20ga shielded wire from cdi to coils and keep as one continuous length.

Maximum recommended wire length is 2M

Read installation guide for important wiring details!

M & W IGNITIONS

Performance & Quality

CAUTION!
HIGH VOLTAGE



DISCONNECT POWER BEFORE WORKING ON UNIT

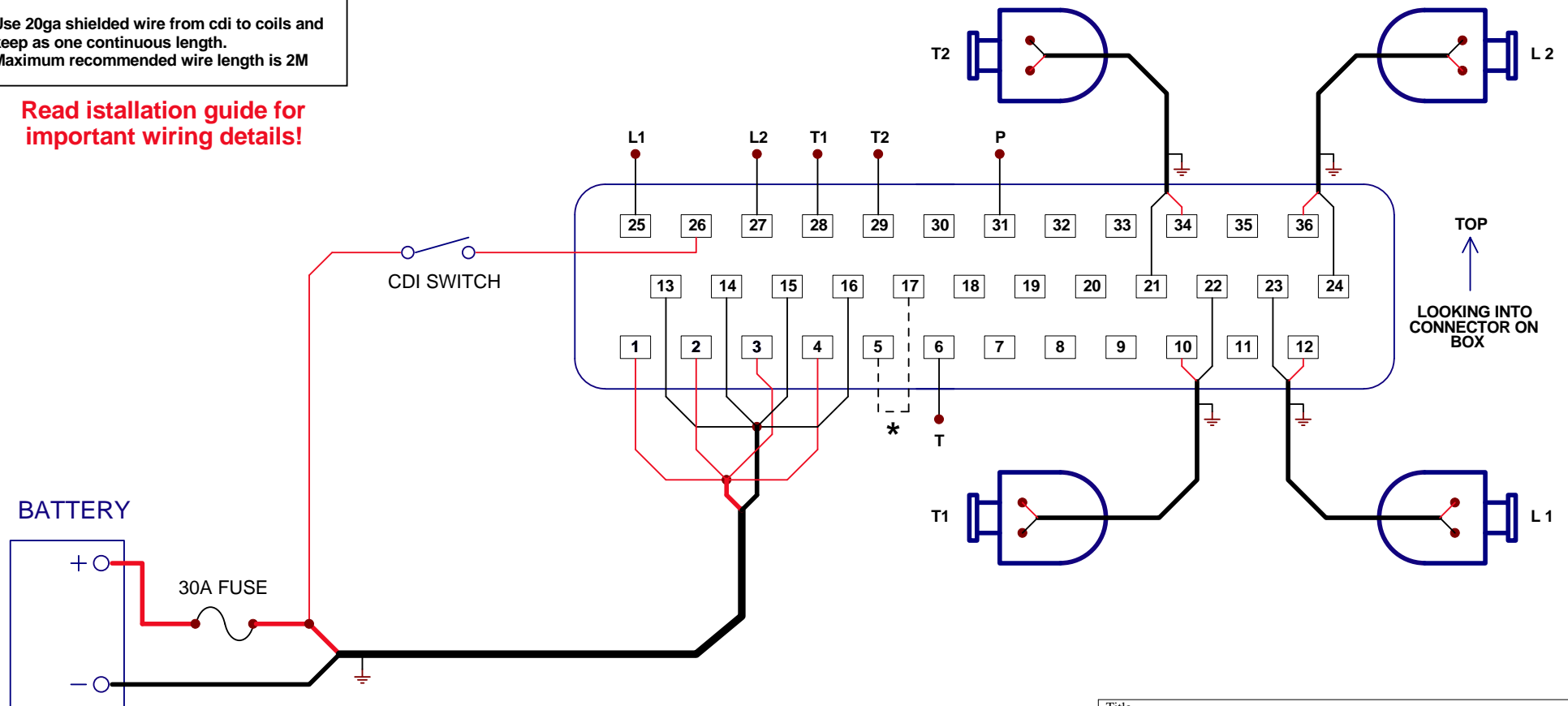

TOP
↑
LOOKING INTO CONNECTOR ON BOX

* See installation instructions

Title			PRO-DRAG4 ROTARY DIRECT FIRE
Size	Number	(C) M&W Ignitions	
A4		Revision	21.10.16.1
Date:	21-Nov-2016	Sheet1 of 1	
File:	D:\M&W\...\Pro-Drag4 Rotary S4 2.sch	Drawn By:	WAG

CAUTION!
HIGH VOLTAGE



**DISCONNECT POWER BEFORE
WORKING ON UNIT**



PRO-Drag4
HIGH ENERGY
MICROPROCESSOR CDI

Slot dimensions - 5mm * 10mm

Title				PRO-DRAG4 ROTARY			
Size	Number		Revision		Date		Sheet
A4	(C) M&W Ignitions		22.10.16.1		22-Oct-2016		1 of 1
File:				D:\M&W\...\Pro-Drag4 Rotary S4 dimensions.dwg			
Drawn By:				WAG			