



Pro-Drag8

(Series 3)
8 channel 500mJ
CAPACITOR DISCHARGE
IGNITION

SALES@MWIGNITIONS.COM
Ph. +61-2-9668-8481

CONTENTS:

2. Caution
3. Installation notes
7. Ignition coil information
8. Mounting dimensions
9. Connections and specifications
10. 8 Channel sequential ignition
11. Shielding & EMC compliance
12. **Change Log**

**CHECK WEBSITE FOR UPDATED INSTRUCTIONS
& ADDITIONAL INFORMATION**

CAUTION

**THIS WIRING DIAGRAM IS
APPLICABLE ONLY TO IGNITION
SYSTEMS WITH SERIAL NUMBER
PREFIX STARTING**

75xxxx

**USE OF INCORRECT DIAGRAM WILL
VOID WARRANTY AND MAY DAMAGE
UNIT**

**INSTALLATION OF THIS PRODUCT
SHOULD NOT BE ATTEMPTED
WITHOUT ADVANCED KNOWLEDGE
AND SKILLS IN AUTOMOTIVE WIRING
AND IGNITION SYSTEMS**

**IMPROPER INSTALLATION OR
OPERATION MAY CAUSE DAMAGE
TO IGNITION SYSTEM AND/OR
IGNITION COIL**

INSTALLATION NOTES

(S3 Pro-Drag 500mJ systems only)

MOUNTING

Do not mount the unit where it will be exposed to water or other liquids, ensure the bottom condensation slots are unobstructed and oriented to permit gravity drain. Select a location away from intense heat and if required provide a source of cooling air to remove internally generated heat.

Failure to use supplied rubber mounts will void warranty!

IGNITION LEADS

Do not use plain metal wire or carbon core ignition leads.

Use spiral wound inductively suppressed metal core ignition leads such as those available from Magnecor www.magnecor.com.

SPARK PLUGS

The use of use non resistor spark plugs (where possible) will greatly enhance ignition performance.

In some installations the use of resistor spark plugs may be unavoidable. In these cases ensure they are not damaged by testing internal resistance value as part of regular maintenance. Open circuit or high resistance may cause failure of spark plug wires, ignition coils and CDI.

The use surface discharge or semi surface discharge spark plugs are limited to naturally aspirated engines due to their large spark gaps.

INSULATION PRECAUTIONS

Degrease spark plug insulators and coil/plug boots after handling to prevent tracking or insulation breakdown.

Use (supplied) dielectric grease on spark plug insulators and coil/plug boots to increase insulation properties and ease installation/removal. Use of dielectric grease in main connector may reduce water ingress.

WIRING & POWER SUPPLY

M&W CDI systems are designed to blow the external fuse under conditions of over voltage or reverse polarity. Faults such as loose battery terminals, poor wiring or defective alternator/regulator may also cause for this to occur. Fitting a larger capacity fuse won't disable this feature, will void warranty and may cause irreparable damage to unit. **Only fit the recommended size fuse!**

Main connector pins are designed to be roll crimped. Squeeze crimping or soldering will cause distortion resulting in misfiring or incorrect CDI operation.

Wire ignition system directly to battery. If required wire length exceeds recommendations use small paired battery cable (power and ground) to make up distance. Do not rely on vehicle chassis to provide ground path. If connected to a high impedance supply shared with ECU or its sensors erratic operation will be experienced.

Do not use voltage boosters to supply cdi with power.

When using a total loss electrical system install either a 16V or 18V battery to ensure supply voltage does not drop below 13V. If using extended voltage batteries isolate them during charging to prevent excessive voltage reaching the CDI and ECU.

Use twisted shielded pair wire for all coil connections. Twisted pair wire must be used for power/ground. Keep coil wires one continuous length from CDI and do not fit any intermediate connectors into harness. All coil negative wires must be joined at or in the cdi connector. Keep coil primary (CDI) wires away from HT leads, coil HV outlet and coil body to prevent a flashover occurring.

TRIGGERING

Trigger input & coil output numbers (letters) indicate CDI ignition sequence not cylinder number.

500mJ Pro-Drag systems are fixed falling edge trigger.

If CDI trigger edge and ECU ignition edge do not match timing will be erratic!

POWER LEVEL SWITCH

M&W 500mJ ignition systems include a power level switch to allow a reduction of ignition energy during low load conditions.

Do not manually activate this feature. Either install an adjustable 'Hobbs' style manifold pressure switch or use a programmable output from the ECU and wire so input is grounded as engine comes under load.

TUNING

CDI systems are edge triggered and not effected by dwell setting.

M&W CDI systems may reduce combustion delay and percentage misfire requiring a reduction in ignition timing. The resulting changes in combustion characteristics may also require alterations to fuel flow. Set ECU ignition delay to zero and tune engine as required.

Always re tune both fuel and timing curves after installation!

TACHO OUTPUT

The tacho output provides a 50% duty cycle square wave signal at battery supply voltage. This will work with most aftermarket digital tacho's however earlier types and those designed for coil negative triggering may not read accurately.

LED INDICATOR

After applying power to switch wire the LED will illuminate for 1 second and extinguish. The LED will then flash briefly with each consecutive trigger event received (it may be necessary to view the LED directly on axis).

A repeated double flash of the LED may indicate a possible faulty ignition coil, faulty wiring, low supply voltage or damage to the CDI.

TESTING

The CDI may be tested by momentarily grounding the trigger inputs causing the LED to flash and corresponding ignition coil to spark. **Do not conduct this test without grounded spark plugs installed!**

A more comprehensive test procedure may be found on our web site http://www.mwignitions.com/pg_data_sheets.php

SAFETY

Due to extreme energy and voltage levels developed by M&W 500mJ ignition systems it is strongly recommended caution be taken to ensure personnel safety and prevent ignition component damage.

Application of power to ignition system in combination with an inadvertent ignition event from either ECU being powered up/down or engine rotation can cause irreparable damage to ignition coils and CDI. Personnel in close proximity may suffer a painful electrical shock.

1. Install grounded metal studs in engine bay and transfer spark plug ends of HT leads to these between race events or at least when working on engine.
2. Install aircraft style guarded toggle switch in the CDI ignition switch wire circuit and disable it at all times except when running the engine.

INSTALLATION PRECAUTIONS

The main cause of CDI damage is conduction of high voltage to coil primary wiring.

Care must be taken due to the propensity for HV flashovers and insulation breakdown caused by CDI ignitions unique characteristics.

It is essential to fully read and understand these instructions and have a comprehensive knowledge of automotive electrical systems before commencing installation.

For further instructions and cdi information check out the support tab on our web site

<http://www.mwignitions.com>

IGNITION COILS

(Pro-Drag systems only)

COIL SELECTION

For ultimate ignition energy and efficiency use coils specifically designed for CDI use such as the M&W #COI006. Ignition coils primarily designed for inductive ignition will limit CDI performance.

COP COILS

COP (coil on plug) coils were not designed for the energy levels and voltage potentials developed by M&W Pro-Drag systems.

Use COP coils at your own risk with 250mJ systems, DO NOT use COP coils with 500mJ systems.

Use resistive spark plugs with all COP coils. Keep plug gap \leq 0.025" (0.6mm) to prevent coil & CDI damage.

FERRITE CDI COILS

Ferrite core cdi coils provide a lightweight solution for direct fire applications and give high secondary current however they may not be suitable for all applications due to their extremely short arc duration. The high level of EMI emitted by these coils may require additional shielding to prevent electrical interference with the ECU or CDI.

DO NOT wire ferrite coils in parallel pairs!

DO NOT use 'Prufex' brand Mercury coils or AEM pencil coils under any circumstances!

CAUTION!

IGNITION COIL DAMAGE MAY OCCUR IF OPERATED WITH AN EXCESSIVE SPARK GAP



DISCONNECT POWER BEFORE WORKING ON UNIT

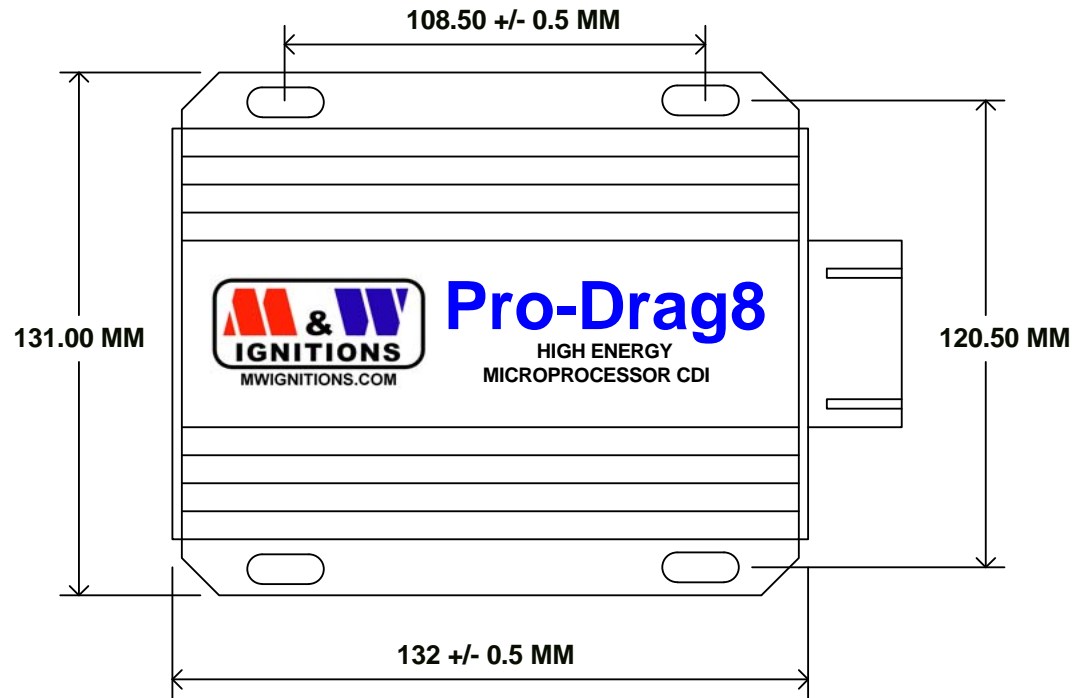

Slot dimensions - 5mm * 10mm

Title		MOUNTING DIMENSIONS	
Size	Number	Revision	
A4	(C) M&W Ignitions	19.06.13.1	
Date:	19-Jun-2013	Sheet 1 of	1
File:	D:\M&W\...\Mounting dimensions.sch	Drawn By:	M&W

FOR DRAG RACING USE ONLY

This unit is not designed for continuous operation in either high or low power modes

M & W IGNITIONS

Performance & Quality since 1996

**CAUTION!
HIGH VOLTAGE**



DISCONNECT POWER BEFORE WORKING ON UNIT

VIEWED FROM BACK OF CONNECTOR



KEEP ALL INPUTS WELL SEPARATED FROM COIL OUTPUTS

1 +12V (Battery)	7 Ground (Battery)	13 Triggers G & H
2 +12V (Battery)	8 Ground (Battery)	14 Triggers C & D
3 Triggers E & F	9 Power level	15 Triggers A & B
4	10	16 Ignition switch
5 Coils E & F +	11 Coil C & D +	17 Coils E/G & F/H -
6 Coils A & B +	12 Coils G & H +	18 Coils A/C & B/D -

SPECIFICATIONS

Supply voltage = 13V - 18V DC negative ground
 Startup voltage = +7V
 Maximum supply current = 20A (per box)
 Shutdown current <700uA
 Maximum ignition frequency = 1,400Hz (combined)
 Maximum energy limit = 700Hz (combined)
 Coil primary voltage = 400/500V
 Spark energy = 320/500 millijoules
 Trigger = 10mA open collector drive
 Maximum continuous temperature = 105°C
 Dimensions = 132L * 110W * 40H
 Weight = 900gm * 2

Title EIGHT CHANNEL 500mJ CDI IGNITION		
Size A4	Number (C) M&W Ignitions	Revision 28.10.15.1
Date: 28-Oct-2015	File: D:\M&W\...\ProDrag8_500_S3_1.sch	Sheet 1 of 1 Drawn By: M&W

**FIRING ORDER MUST
ALTERNATE BETWEEN BOXES**

M & W IGNITIONS

Performance & Quality since 1996

**CAUTION!
HIGH VOLTAGE**



**DISCONNECT POWER BEFORE
WORKING ON UNIT**

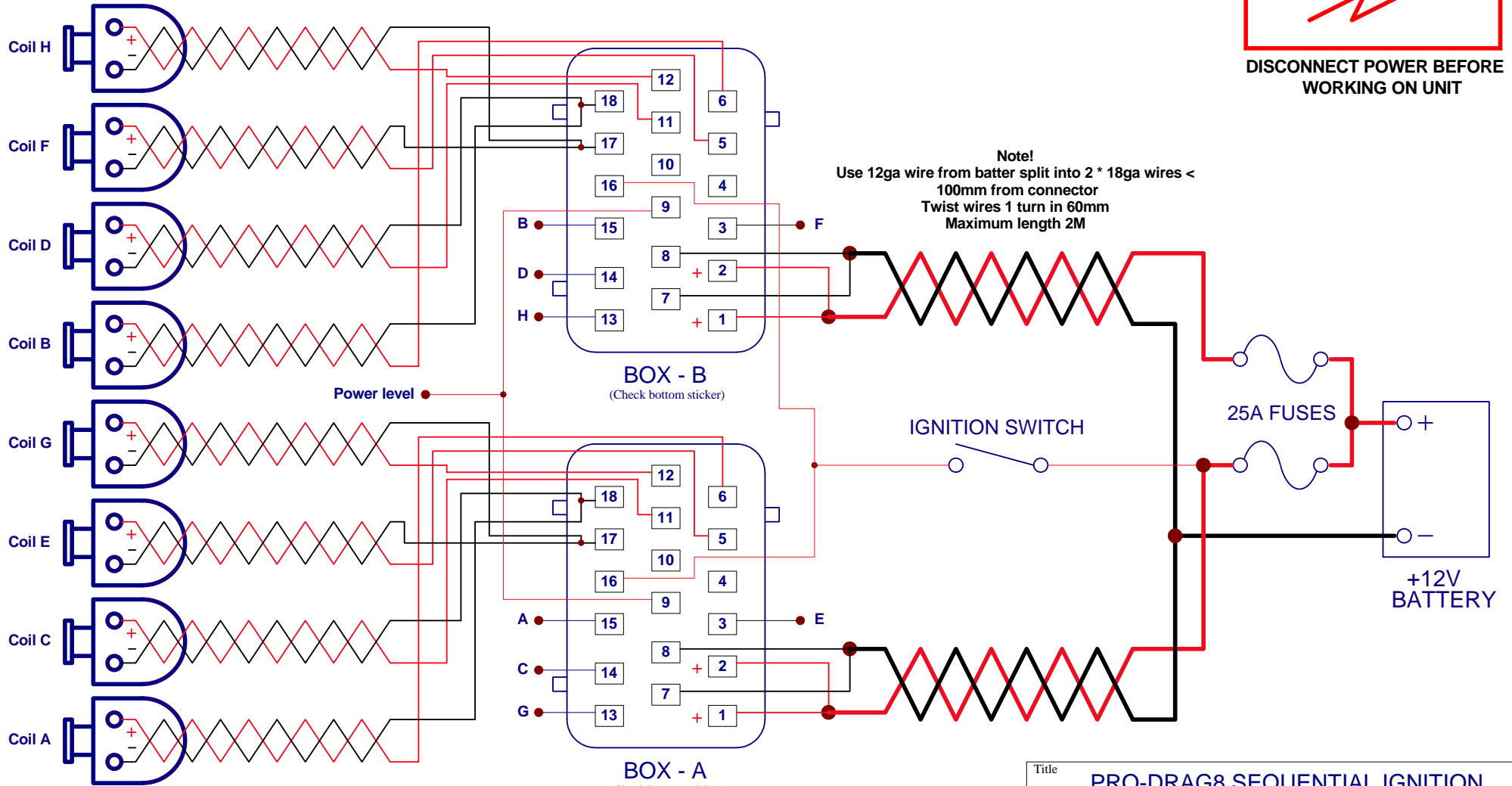

Title			PRO-DRAG8 SEQUENTIAL IGNITION		
Size	Number	(C) M&W Ignitions		Revision	28.10.15.1
A4					
Date:	28-Oct-2015	Sheet 1 of	1	Drawn By:	M&W
File:	D:\M&W\...\ProDrag8_500_S3_2.sch				

M & W IGNITIONS

Performance & Quality since 1996

**CAUTION!
HIGH VOLTAGE**

DISCONNECT POWER BEFORE
WORKING ON UNIT

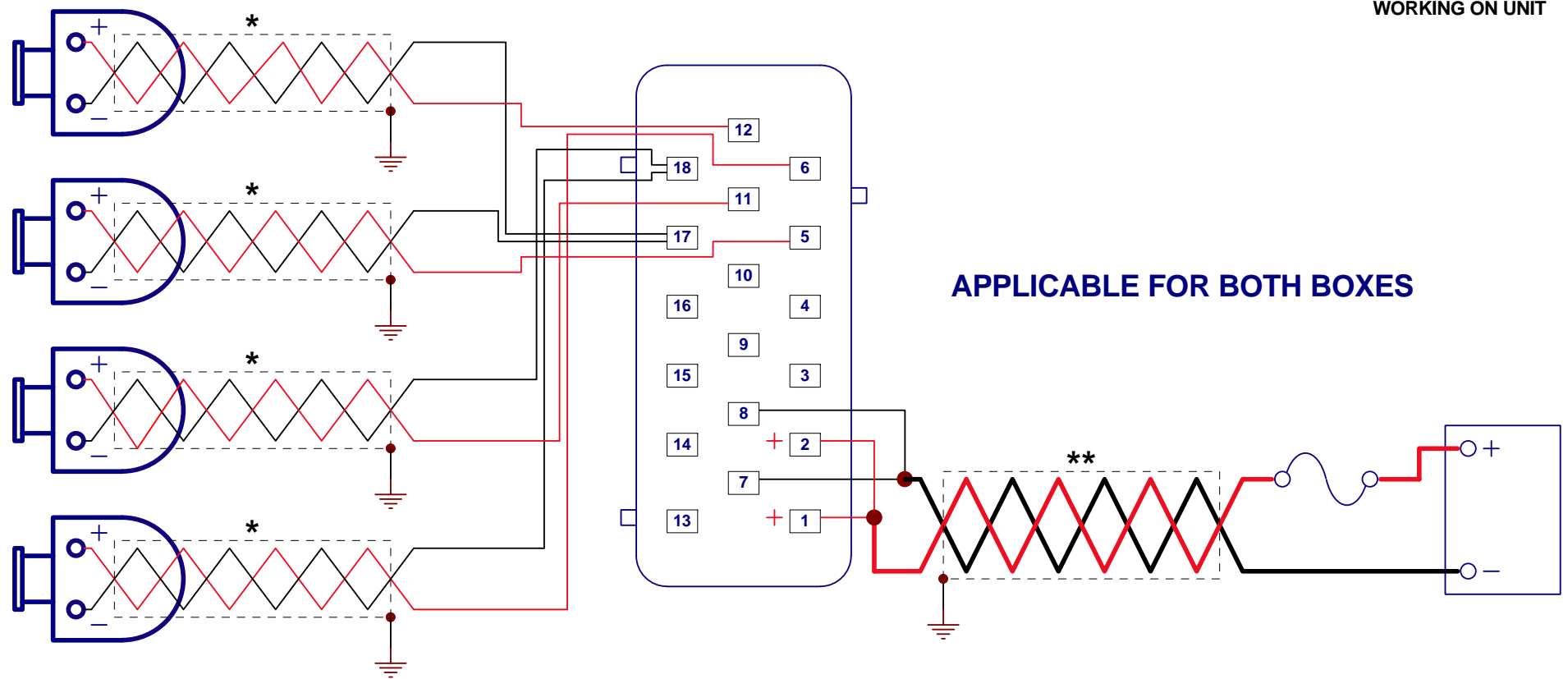

- * Use twisted shielded cable grounded at one end only
- ** Shielded power cables required for Australian EMC compliance

Title			SHIELDING & EMC COMPLIANCE
Size	Number	(C) M&W Ignitions	
A4		Revision	12.06.13.1
Date:	19-Jun-2013	Sheet 1 of 1	
File:	D:\M&W\...\EMC.sch	Drawn By:	M&W

PD8 500 S3 CHANGELOG

Date	Alterations
28/10/2015	Change recommended wire gauge for power and coils