



PRO-14d

4 CHANNEL

(MOTEC[®] IGNITION EXPANDER)

CAPACITOR DISCHARGE IGNITION

SALES@MWIGNITIONS.COM
Ph. +61-2-9668-8481

CONTENTS:

2. Caution
3. Installation notes
7. Ignition coil information
8. Mounting dimensions
9. Connections and specifications
10. Direct fire wiring diagram
11. Shielding & EMC compliance

**CHECK WEBSITE FOR UPDATED INSTRUCTIONS
& ADDITIONAL INFORMATION**

CAUTION

**THIS WIRING DIAGRAM IS
APPLICABLE ONLY TO IGNITION
SYSTEMS WITH SERIAL NUMBER
PREFIX STARTING**

70xxxx

**USE OF INCORRECT DIAGRAM WILL
VOID WARRANTY AND MAY DAMAGE
UNIT**

**THE INSTALLATION OF HIGH ENERGY IGNITION
SYSTEMS MAY REQUIRE ADVANCED
KNOWLEDGE AND SKILLS.**

**IMPROPER INSTALLATION OR OPERATION OF
THIS UNIT COULD CAUSE DAMAGE TO IGNITION
SYSTEM AND IGNITION COIL**

INSTALLATION NOTES

(MoTeC[®] IEX compatible street systems only)

MOUNTING

Do not mount the unit where it will be exposed to water or other liquids, ensure the bottom condensation slots are unobstructed and oriented to permit gravity drain. Select a location away from intense heat and if required provide a source of cooling air to remove internally generated heat.

Failure to use supplied rubber mounts will void warranty!

IGNITION LEADS

Do not use plain metal wire or carbon core ignition leads.

Use spiral wound inductively suppressed metal core ignition leads such as those available from Magnecor www.magnecor.com.

SPARK PLUGS

The use of use non resistor spark plugs (where possible) will greatly enhance ignition performance.

In some installations the use of resistor spark plugs may be unavoidable. In these cases ensure they are not damaged by measuring internal resistance value as part of regular maintenance and monitor for changes. Open circuit or high resistance may cause failure of spark plug wires, ignition coils and CDI.

Surface discharge and semi surface discharge spark plugs are designed for use with CDI ignition however be aware they have a large non-adjustable spark gap suitable only for naturally aspirated or low boost applications.

INSULATION PRECAUTIONS

Degrease spark plug insulators and coil/plug boots after handling to prevent tracking or insulation breakdown.

Use (supplied) dielectric grease on spark plug insulators and coil/plug boots to increase insulation properties and ease

installation/removal. Use of dielectric grease in main connector may reduce water ingress.

WIRING & POWER SUPPLY

M&W CDI systems are designed to blow the external fuse under conditions of over voltage or reverse polarity. Faults such as loose battery terminals, poor wiring or defective alternator/regulator may also cause for this to occur. Fitting a larger capacity fuse won't disable this feature, will void warranty and may cause irreparable damage to unit. **Only fit the recommended size fuse!**

Main connector pins are designed to be roll crimped. Squeeze crimping or soldering will cause distortion resulting in misfiring or incorrect CDI operation.

Wire ignition system directly to battery. If required wire length exceeds recommendations use small paired battery cable (power and ground) to make up distance. Do not rely on vehicle chassis to provide ground path. If connected to a high impedance supply shared with ECU or its sensors erratic operation will be experienced.

Do not use voltage boosters as most can't provide the instantaneous current required for correct CDI operation.

When using a total loss electrical system install either a 16V or 18V battery to ensure adequate supply voltage. If using extended voltage batteries isolate them during charging to prevent excessive voltage reaching the CDI and ECU.

Use twisted pair wire for all power and coil connections. For improved noise suppression and to comply with Australian EMC 'C Tick' standards use twisted shielded pair wire for coils. Twisted pair wire must be used for power/ground. Keep coil wires one continuous length from CDI and do not fit any intermediate connectors into harness. All coil negative wires must be joined at or in the cdi connector. Keep coil primary (CDI) wires away from HT leads, coil HV outlet and coil body to prevent a flashover occurring.

TRIGGERING

M&W IEX trigger ignition systems are designed to directly replicate the function of a Motec Ignition Expander unit. Due to the complex nature of ECU configuration it is best to consult your Motec distributor for assistance with this setup.

Trigger input & coil output numbers (letters) indicate CDI ignition sequence not cylinder number.

MODE SELECTION

When using M&W IEX cdi's with Motec M4/M48 ecu's join the Mode and Signal Ground terminals in the main connector. See applicable diagram for correct terminal numbers.

POWER LEVEL SWITCH

Some M&W Pro street systems are provided with a (active low) power level switch. Do not manually activate this feature or operate continuously as this will significantly increase spark plug wear and system current draw. Activate by grounding input through either a 'Hobbs' style manifold pressure switch or programmable output from the ECU when elevated energy levels are required.

TUNING

CDI systems are 'edge triggered' and not effected by dwell settings.

M&W CDI systems may reduce combustion delay and percentage misfire requiring a reduction in ignition timing. The resulting changes in combustion characteristics may also require alterations to fuel flow. Set ECU ignition delay to zero and tune engine as required.

Always re tune both fuel and timing curves after installing CDI ignition.

TACHO OUTPUT

The tacho output provides a 50% duty cycle square wave signal at battery supply voltage. This signal will work with most aftermarket digital tacho's however those designed for coil negative triggering may not read accurately. In this case use a tacho adaptor such as the M&W TAC002.

LED INDICATOR

After applying power to switch wire the LED will illuminate for 1 second and extinguish. The LED will then flash briefly with each consecutive trigger event received (it may be necessary to view the LED directly on axis).

A repeated double flash of the LED may indicate a possible faulty ignition coil, faulty wiring, low supply voltage or damage to the CDI.

TESTING

It is not possible to manually trigger MoTeC[®] IEX compatible CDI systems therefore a self test mode has been built into firmware. By grounding this input before powering unit it will sequentially fire all outputs and flash the LED in sync. To exit test mode disconnect power from unit and remove test ground connection.

Do not conduct this test without grounded spark plugs installed!

INSTALLATION PRECAUTIONS

The main cause of CDI damage is conduction of high voltage to coil primary wiring.

Care must be taken due to the propensity for HV flashovers and insulation breakdown caused by CDI ignitions unique characteristics.

It is important to fully read and understand these instructions and have a good knowledge of automotive electrical systems before commencing installation.

For further instructions and cdi information check out the support tab and Q&A section on our web site
<http://www.mwignitions.com>

IGNITION COILS

(Pro-Street systems only)

COIL SELECTION

Most inductive ignition coils will work reasonably well with CDI systems however for ultimate ignition energy and efficiency use a coil specifically designed for CDI use.

COP COILS

COP (coil on plug) coils with inbuilt drivers are not suitable for use with CDI ignition. COP coils designed for inductive ignition may contain a blocking diode in the secondary winding which must be considered during wiring (see coil polarity note below). **Use resistive spark plugs with all COP coils. Keep plug gap < 0.025" (0.6mm) to prevent coil damage. DO NOT use AEM pencil coils under any circumstances!**

FERRITE CDI COILS

Ferrite core cdi coils provide a lightweight solution for direct fire applications and give high secondary current however they may not be suitable for all applications due to their extremely short arc duration. The high level of EMI emitted by these coils may also require additional shielding to prevent electrical interference with the ECU or CDI. **Do not use ferrite coils in parallel wired pairs!**

COIL POLARITY

All diagrams are shown for cdi style coils. For correct operation with inductive ignition coils wire the primary connections in reverse to maintain correct spark plug polarity.

CAUTION!

**IGNITION COIL DAMAGE MAY OCCUR IF
OPERATED WITH AN EXCESSIVE SPARK GAP**



DISCONNECT POWER BEFORE WORKING ON UNIT

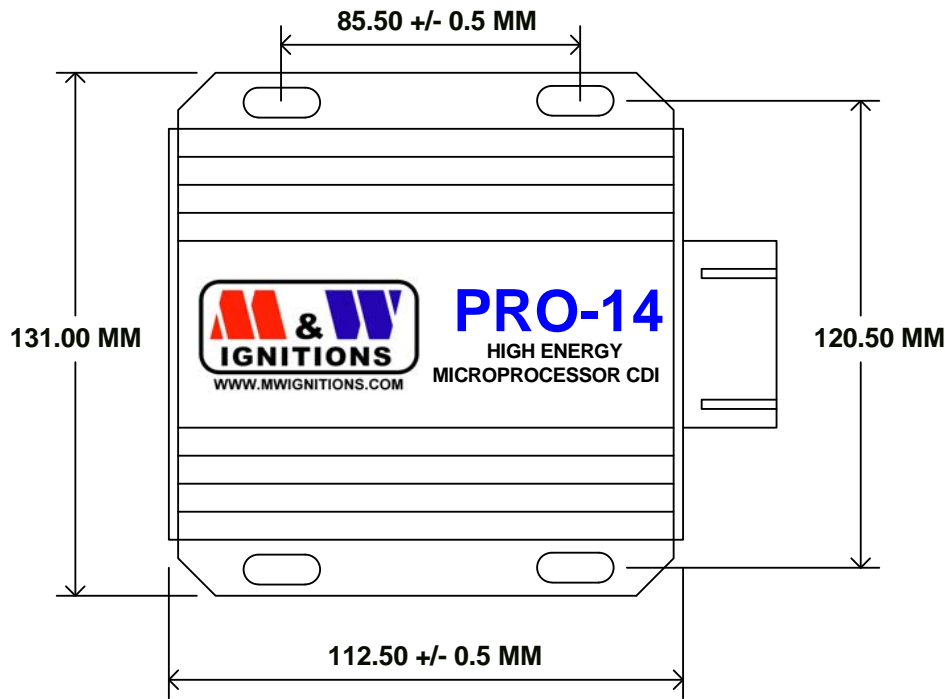

Slot dimensions - 5mm * 10mm

Title			MOUNTING DIMENSIONS		
Size	Number	Revision			
A4	PRO-14d S3	13.05.13.1			
Date:	13-May-2013	Sheet	1	of 1	
File:	D:\M&W\Pro14d_S3_Mounting dimensions.dwg		Drawn By:	M&W	

M & W IGNITIONS

Performance & Quality since 1996

**CAUTION!
HIGH VOLTAGE**



**DISCONNECT POWER BEFORE
WORKING ON UNIT**

VIEWED FROM BACK OF CONNECTOR



KEEP ALL INPUTS WELL SEPARATED FROM COIL OUTPUTS

1 +12V (Battery)	7 Ground (Battery)	13 IEX input
2 +12V (Battery)	8 Ground (Battery)	14
3 Self test	9 Mode	15 Power level
4 Tacho	10 Signal ground	16 Ignition switch
5 Coil 3 +	11 Coil 2 +	17 Coil 3 & 4 -
6 Coil 1 +	12 Coil 4 +	18 Coil 1 & 2 -

SPECIFICATIONS

Supply voltage = 13V - 18V DC negative ground
 Startup voltage = 6V
 Maximum supply current = 7.0A
 Power off current < 700uA
 Maximum ignition frequency = 1,200Hz
 Maximum energy limit = 700Hz/550 Hz
 Coil primary voltage = 460V/540V
 Spark energy = 115/150 millijoules
 Trigger = MoTeC compatible IEX input
 Tacho = 12V, 100mA square wave
 Maximum allowable case temperature = 105°C
 Dimensions = 112L * 110W * 40H
 Weight = 570gm

Title **FOUR CHANNEL MoTeC IEX CDI IGNITION**

Size A4	Number (C) M&W Ignitions	Revision 25.06.13.1
Date: 25-Jun-2013	Sheet 1 of 1	Drawn By: M&W
File: D:\M&W\...\Pro14d_S3_1.sch		

M & W IGNITIONS

Performance & Quality since 1996

**CAUTION!
HIGH VOLTAGE**

DISCONNECT POWER BEFORE
WORKING ON UNIT

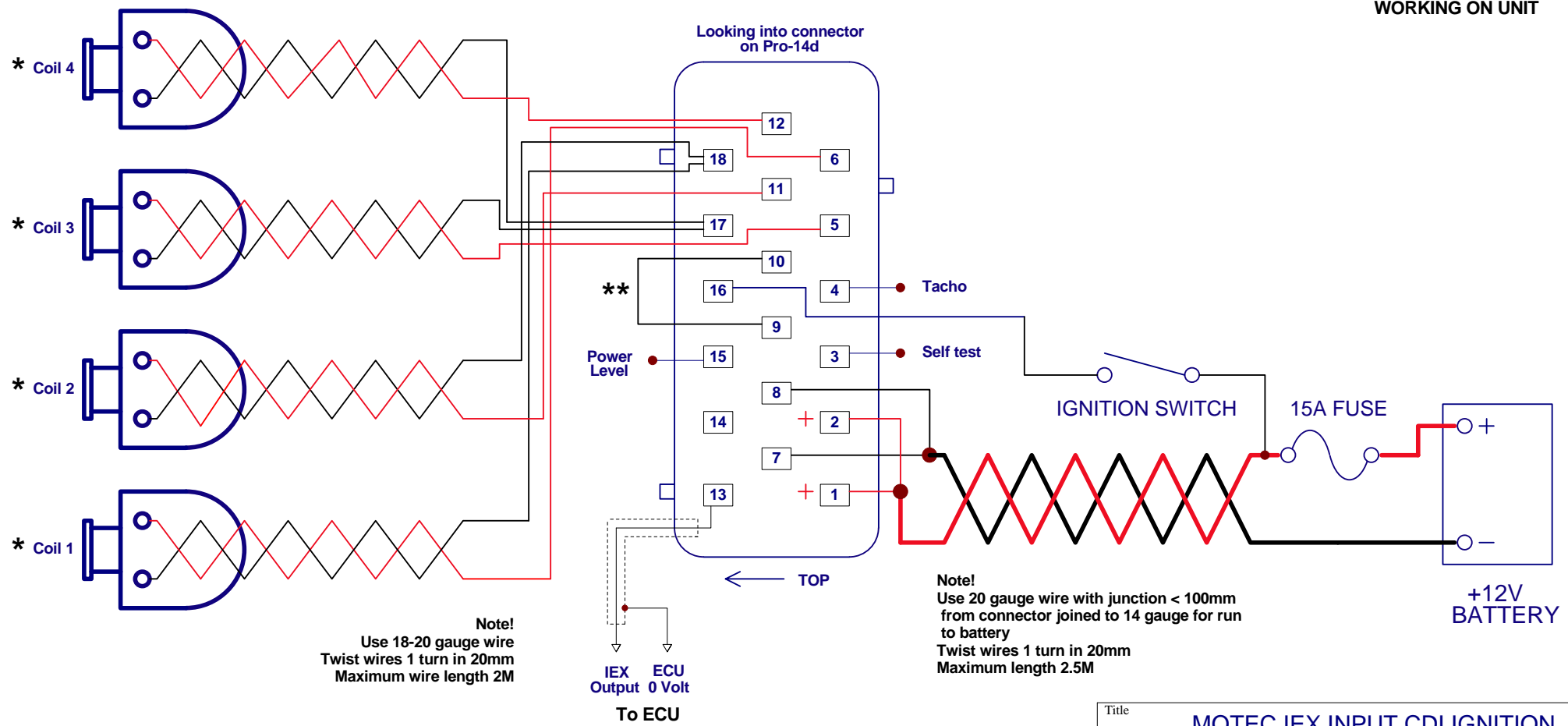

- * Firing order not cylinder number
- ** Join terminals 9 & 10 for M4 / M48 mode

Title			MOTEC IEX INPUT CDI IGNITION		
Size	Number			Revision	
A4	PRO-14d S3			13.05.13.1	
Date:	13-May-2013	Sheet 1 of	1		
File:	D:\M&W\...\Pro14d_S3_2.sch	Drawn By:	M&W		

M & W IGNITIONS

Performance & Quality since 1996

CAUTION!
HIGH VOLTAGE



DISCONNECT POWER BEFORE WORKING ON UNIT

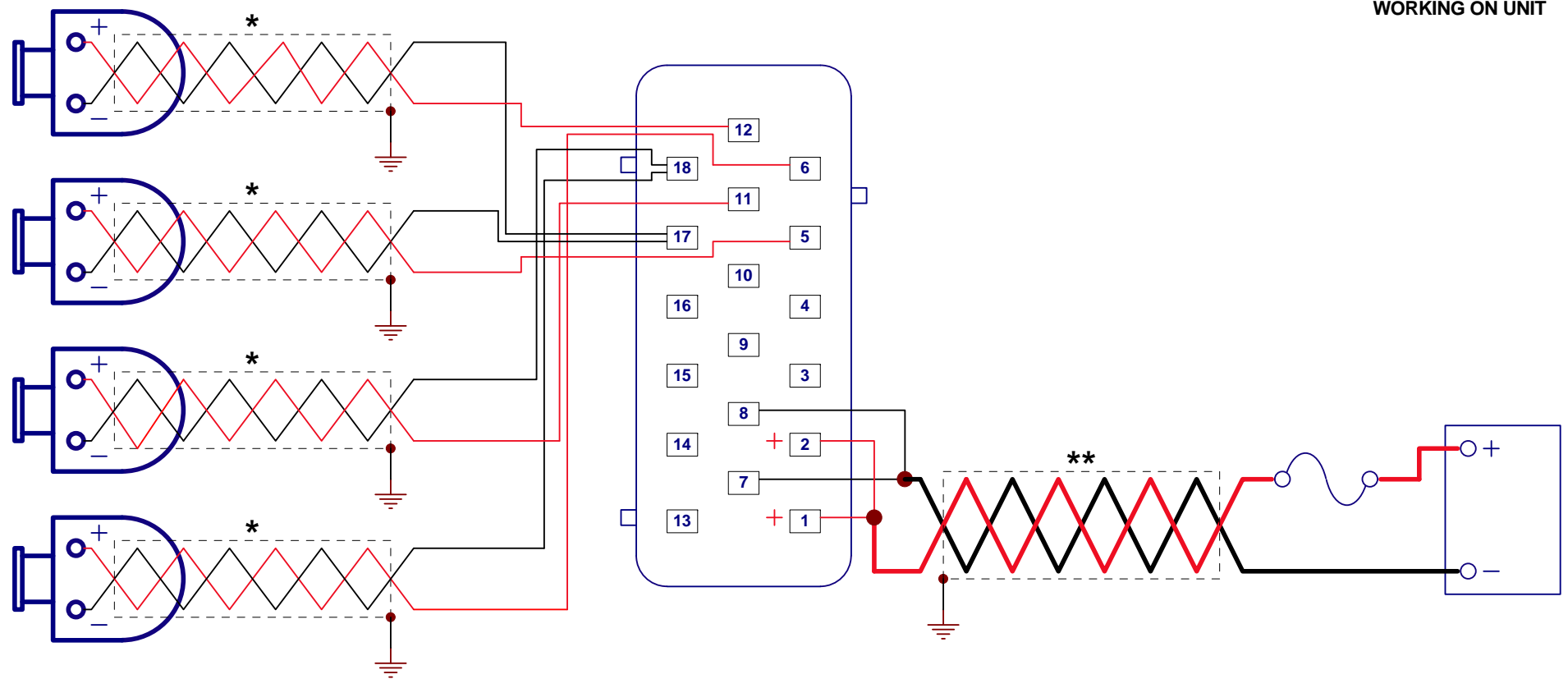

- * Use twisted shielded cable grounded at one end only
- ** Shielded power cables required for Australian EMC compliance

Title			SHIELDING & EMC COMPLIANCE		
Size	Number	Revision			
A4	PRO-14d S3	13.05.13.1			
Date:	13-May-2013	Sheet 1 of	1		
File:	D:\M&W\Diagrams\Pro-14d S3\EMC.sch	Drawn By:	M&W		