



# **PRO-18**

## **8 CHANNEL CAPACITOR DISCHARGE IGNITION**

**SALES@MWIGNITIONS.COM**  
**Ph. +61-2-9668-8481**

### **CONTENTS:**

2. Caution
3. Installation notes
7. Ignition coil information
8. Mounting dimensions
9. Connections and specifications
10. 8 coil sequential ignition
11. 4 rotor Mazda direct fire ignition
12. Shielding & EMC compliance

**CHECK WEBSITE FOR UPDATED INSTRUCTIONS  
& ADDITIONAL INFORMATION**

# **CAUTION**

**THIS WIRING DIAGRAM IS  
APPLICABLE ONLY TO IGNITION  
SYSTEMS WITH SERIAL NUMBER  
PREFIX STARTING**

**76xxxx**

**USE OF INCORRECT DIAGRAM WILL  
VOID WARRANTY AND MAY DAMAGE  
UNIT**

**THE INSTALLATION OF HIGH ENERGY IGNITION  
SYSTEMS MAY REQUIRE ADVANCED  
KNOWLEDGE AND SKILLS.**

**IMPROPER INSTALLATION OR OPERATION OF  
THIS UNIT COULD CAUSE DAMAGE TO IGNITION  
SYSTEM AND IGNITION COIL**

# INSTALLATION NOTES

(Pro series street systems only)

## MOUNTING

Do not mount the unit where it will be exposed to water or other liquids, ensure the bottom condensation slots are unobstructed and oriented to permit gravity drain. Select a location away from intense heat and if required provide a source of cooling air to remove internally generated heat.

**Failure to use supplied rubber mounts will void warranty!** Suitable replacement anti vibration mounts are M&W #MNT002, or Paulstra Radiaflex #521128.

## IGNITION LEADS

Do not use plain metal wire or carbon core ignition leads.

Use spiral wound inductively suppressed metal core ignition leads such as those available from Magnecor [www.magnecor.com](http://www.magnecor.com).

## SPARK PLUGS

The use of use non resistor spark plugs (where possible) will greatly enhance ignition performance.

In some installations the use of resistor spark plugs may be unavoidable. In these cases ensure they are not damaged by testing internal resistance value as part of regular maintenance. Open circuit or high resistance may cause failure of spark plug wires, ignition coils and CDI.

Surface discharge and semi surface discharge spark plugs are designed for use with CDI ignition however be aware they have a large non-adjustable spark gap suitable only for naturally aspirated or low boost applications.

## INSULATION PRECAUTIONS

Degrease spark plug insulators and coil/plug boots after handling to prevent tracking or insulation breakdown.

Use (supplied) dielectric grease on spark plug insulators and coil/plug boots to increase insulation properties and ease installation/removal. Use of dielectric grease in main connector may reduce water ingress.

## WIRING & POWER SUPPLY

M&W CDI systems are designed to blow the external fuse under conditions of over voltage or reverse polarity. Faults such as loose battery terminals, poor wiring or defective alternator/regulator may also cause for this to occur. Fitting a larger capacity fuse won't disable this feature, will void warranty and may cause irreparable damage to unit. **Only fit the recommended size fuse!**

Main connector pins are designed to be roll crimped. Squeeze crimping or soldering will cause distortion resulting in misfiring or incorrect CDI operation.

Wire ignition system directly to battery. If required wire length exceeds recommendations use small paired battery cable (power and ground) to make up distance. Do not rely on vehicle chassis to provide ground path. If connected to a high impedance supply shared with ECU or its sensors erratic operation will be experienced.

Do not use voltage boosters as most can't provide the instantaneous current required for correct CDI operation.

When using a total loss electrical system install either a 16V or 18V battery to ensure adequate supply voltage. If using extended voltage batteries isolate them during charging to prevent excessive voltage reaching the CDI and ECU.

Use twisted pair wire for all power and coil connections. For improved noise suppression and to comply with Australian EMC 'C Tick' standards use twisted shielded pair wire for coils. Twisted pair wire must be used for power/ground. Keep coil wires one continuous length from CDI and do not fit any intermediate connectors into harness. All coil negative wires must be joined at or in the cdi connector. Keep coil primary (CDI) wires away from HT leads, coil HV outlet and coil body to prevent a flashover occurring.

## TRIGGERING

Trigger input & coil output numbers (letters) indicate CDI ignition sequence not cylinder number.

M&W Pro street CDI systems default to falling edge ignition. To select rising edge ignition install a jumper wire between 'Trigger Edge' and 'Signal Ground' pins. Where the ECU contains an inbuilt igniter it may be necessary to use rising edge ignition. **If CDI and ECU trigger edges do not match timing will be erratic!**

When using a Hall sensor to trigger CDI changing trigger edge will alter whether system fires on advancing or retreating target edge.

### POWER LEVEL SWITCH

Some M&W Pro street systems are provided with a (active low) power level switch. Do not manually activate this feature or operate continuously as this will significantly increase spark plug wear and system current draw. Activate by grounding input through either a 'Hobbs' style manifold pressure switch or programmable output from the ECU when elevated energy levels are required.

### TWO SPARK SWITCH

Some M&W Pro street systems are provided with a two spark switch for part load conditions in lean burn engines. Do not manually activate this feature as it will significantly increase spark plug wear and double system current draw. Activate by grounding the input through a programmable ECU output.

### TUNING

CDI systems are 'edge triggered' and not effected by dwell settings.

M&W CDI systems may reduce combustion delay and percentage misfire requiring a reduction in ignition timing. The resulting changes in combustion characteristics may also require alterations to fuel flow. Set ECU ignition delay to zero and tune engine as required.

**Always re tune both fuel and timing curves after installing CDI ignition.**

### TACHO OUTPUT

The tacho output provides a 50% duty cycle square wave signal at battery supply voltage. This will work with most aftermarket digital tacho's however earlier types and those designed for coil negative triggering may not read accurately.

## LED INDICATOR

After applying power to switch wire the LED will illuminate for 1 second and extinguish. The LED will then flash briefly with each consecutive trigger event received (it may be necessary to view the LED directly on axis).

A repeated double flash of the LED may indicate a possible faulty ignition coil, faulty wiring, low supply voltage or damage to the CDI.

## TESTING

The CDI may be tested by momentarily grounding the trigger inputs causing the LED to flash and corresponding ignition coil to spark. **Do not conduct this test without grounded spark plugs installed!**

A more comprehensive test procedure may be found on our web site [http://www.mwignitions.com/pg\\_data\\_sheets.php](http://www.mwignitions.com/pg_data_sheets.php)

## INSTALLATION PRECAUTIONS

**The main cause of CDI damage is conduction of high voltage to coil primary wiring.**

Care must be taken due to the propensity for HV flashovers and insulation breakdown caused by CDI ignitions unique characteristics.

It is important to fully read and understand these instructions and have a good knowledge of automotive electrical systems before commencing installation.

For further instructions and cdi information check out the support tab on our web site <http://www.mwignitions.com>

# IGNITION COILS

(Pro-Street systems only)

## COIL SELECTION

Most inductive ignition coils will work reasonably well with CDI systems however for ultimate ignition energy and efficiency use a coil specifically designed for CDI use.

## COP COILS

COP (coil on plug) coils with inbuilt drivers are not suitable for use with CDI ignition. COP coils designed for inductive ignition may contain a blocking diode in the secondary winding which must be considered during wiring (see coil polarity note below). **Use resistive spark plugs with all COP coils. Keep plug gap < 0.025" (0.6mm) to prevent coil damage. DO NOT use AEM pencil coils under any circumstances!**

## FERRITE CDI COILS

Ferrite core cdi coils provide a lightweight solution for direct fire applications and give high secondary current however they may not be suitable for all applications due to their extremely short arc duration. The high level of EMI emitted by these coils may also require additional shielding to prevent electrical interference with the ECU or CDI. **Do not use ferrite coils in parallel wired pairs!**

## COIL POLARITY

All diagrams are shown for cdi style coils. For correct operation with inductive ignition coils wire the primary connections in reverse to maintain correct spark plug polarity.

**CAUTION!**

**IGNITION COIL DAMAGE MAY OCCUR IF  
OPERATED WITH AN EXCESSIVE SPARK GAP**



**DISCONNECT POWER BEFORE WORKING ON UNIT**

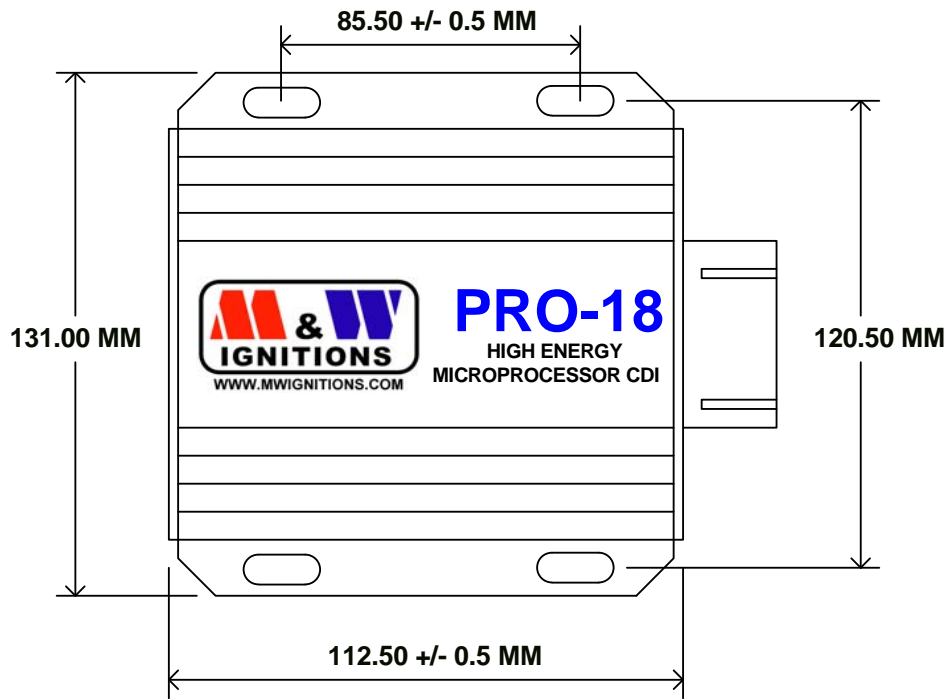

**Slot dimensions - 5mm \* 10mm**

Title				<b>MOUNTING DIMENSIONS</b>	
Size	Number	Revision			
A4	<b>(C) M&amp;W Ignitions</b>	25.06.13.1			
Date:	28-Jun-2013	Sheet 1 of	1		
File:	D:\M&W\...\Mounting dimensions.sch	Drawn By:	M&W		



# M & W IGNITIONS

Performance & Quality since 1996

**CAUTION!  
HIGH VOLTAGE**



**DISCONNECT POWER BEFORE  
WORKING ON UNIT**

**VIEWED FROM BACK OF CONNECTOR**



**KEEP ALL INPUTS WELL SEPARATED FROM COIL OUTPUTS**

<b>1</b> +12V (Battery)	<b>7</b> Ground (Battery)	<b>13</b> Triggers G & H
<b>2</b> +12V (Battery)	<b>8</b> Ground (Battery)	<b>14</b> Triggers C & D
<b>3</b> Triggers E & F	<b>9</b> Trigger edge	<b>15</b> Triggers A & B
<b>4</b>	<b>10</b> Signal Ground	<b>16</b> Ignition switch
<b>5</b> Coils E & F +	<b>11</b> Coil C & D +	<b>17</b> Coils E/G & F/H -
<b>6</b> Coils A & B +	<b>12</b> Coils G & H +	<b>18</b> Coils A/C & B/D -

## SPECIFICATIONS

Supply voltage = 13V - 18V DC negative ground  
 Startup voltage = +11V  
 Maximum supply current = 7A (per box)  
 Shutdown current <700uA  
 Maximum ignition frequency = 24,000Hz (combined)  
 Maximum energy limit = 14,000Hz (combined)  
 Coil primary voltage = 480V  
 Spark energy = 115 millijoules  
 Trigger = 10mA open collector drive  
 Maximum continuous temperature = 105°C  
 Dimensions = 112L \* 110W \* 40H  
 Weight = 570gm \* 2

Title			<b>EIGHT CHANNEL CDI IGNITION</b>		
Size	Number	<b>(C) M&amp;W Ignitions</b>		Revision	
A4				25.06.13.1	
Date:	28-Jun-2013	Sheet 1 of 1			
File:	D:\M&W\...\Pro-18_S3_1.sch	Drawn By: M&W			

# FIRING ORDER MUST ALTERNATE BETWEEN BOXES

\* See instructions for use of trigger edge selection

# M & W IGNITIONS

Performance & Quality since 1996

**CAUTION!**  
**HIGH VOLTAGE**



**DISCONNECT POWER BEFORE WORKING ON UNIT**

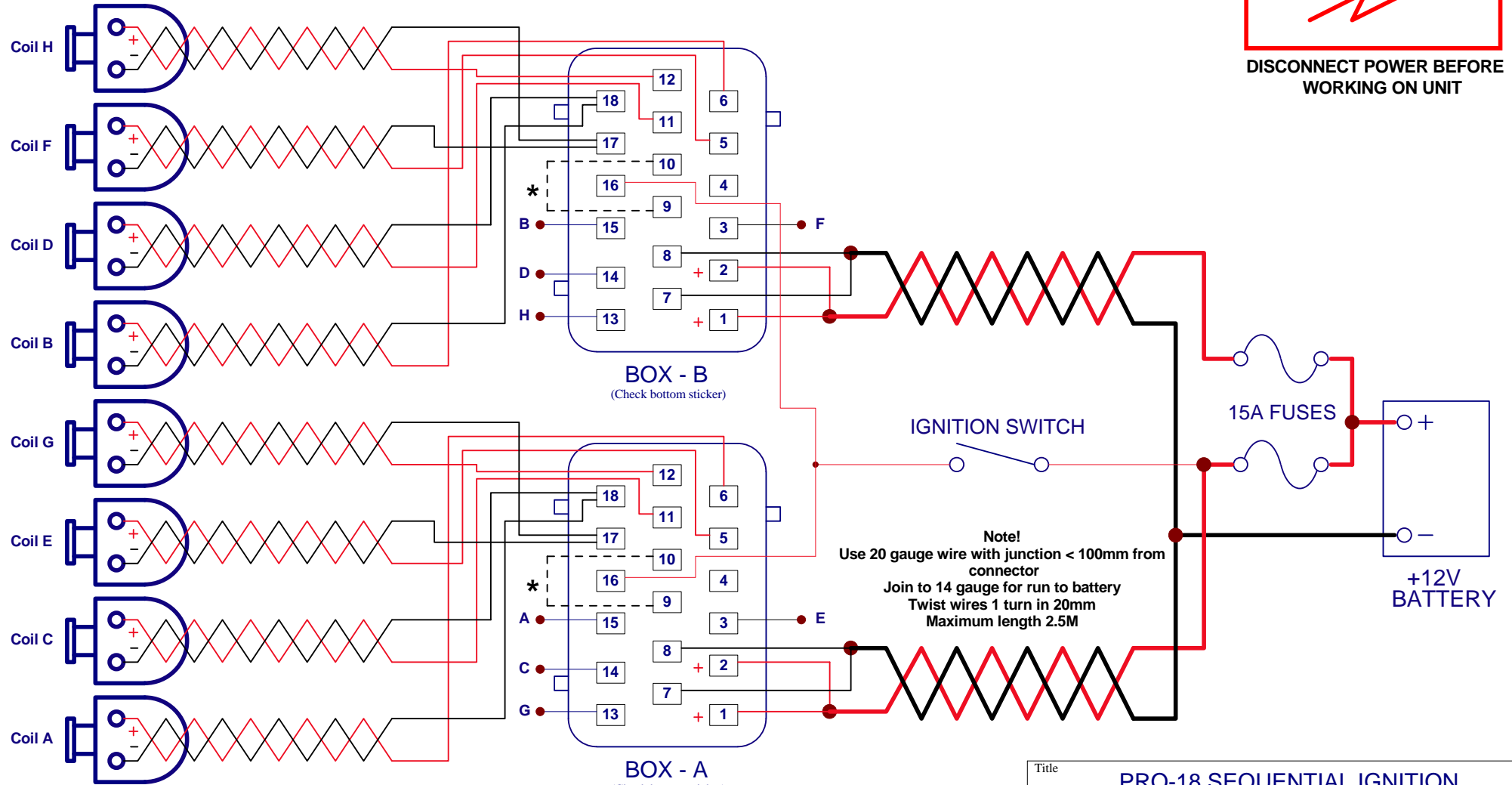

**Note!**  
Use 18-20 gauge wire  
Twist wires 1 turn in 20mm  
Maximum wire length 2M

**CDI CONNECTOR**  
**(LOOKING AT END OF EXTRUSION)**

Title			PRO-18 SEQUENTIAL IGNITION		
Size	Number	(C) M&W Ignitions		Revision	25.06.13.1
A4					
Date:	28-Jun-2013	Sheet	1 of 1	Drawn By:	M&W
File:	D:\M&W\...\Pro-18_S3_2.sch				

# M & W IGNITIONS

Performance & Quality since 1996

**CAUTION!**  
**HIGH VOLTAGE**

**DISCONNECT POWER BEFORE WORKING ON UNIT**

\* See instructions for use of trigger edge selection

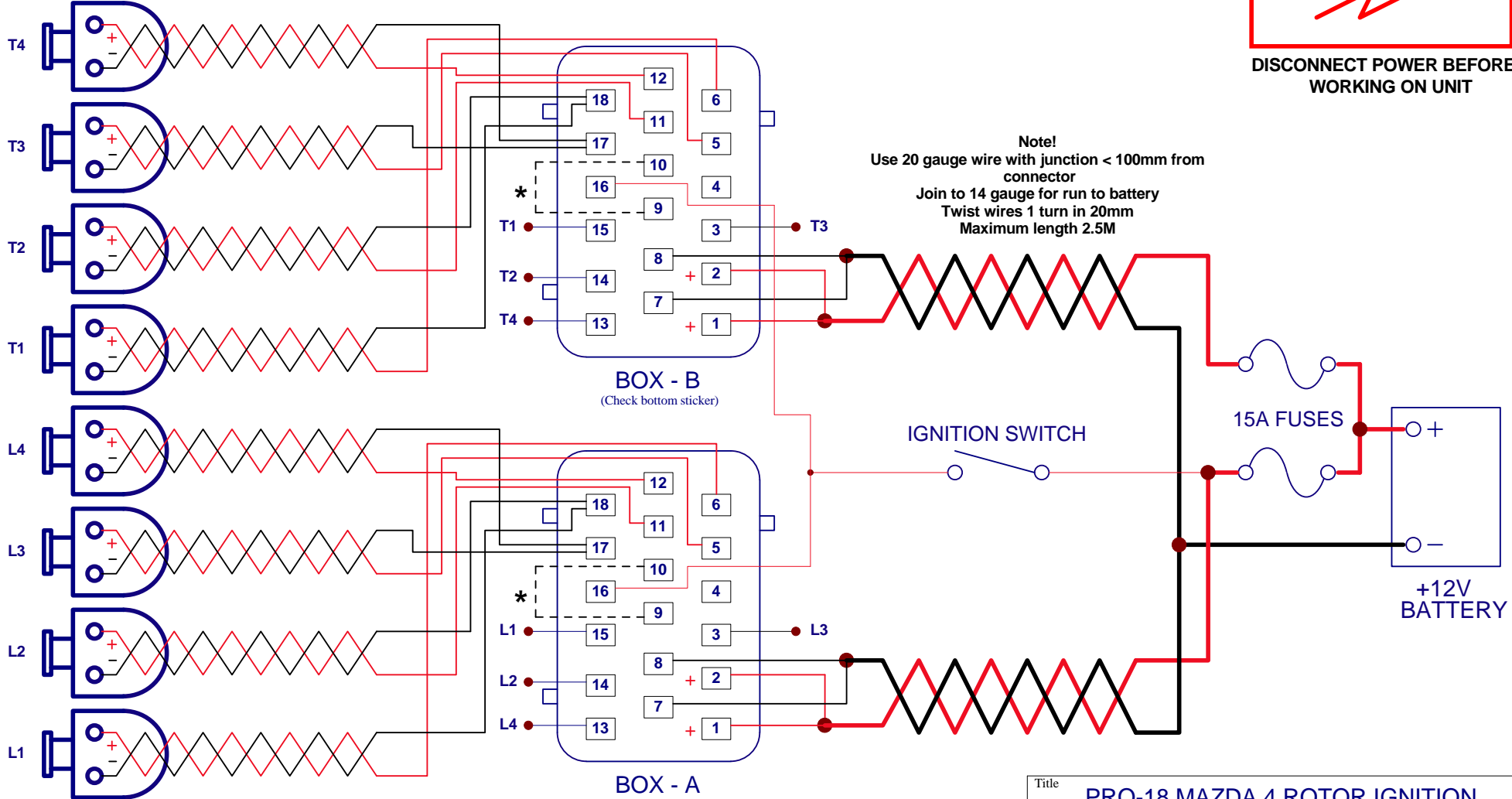

**Note!**  
Use 18-20 gauge wire  
Twist wires 1 turn in 20mm  
Maximum wire length 2M

Title			<b>PRO-18 MAZDA 4 ROTOR IGNITION</b>		
Size	Number	<b>(C) M&amp;W Ignitions</b>		Revision	
A4				25.06.13.1	
Date:	28-Jun-2013	Sheet 1 of	1	Drawn By:	M&W
File:	D:\M&W\...\Pro-18_S3_3.sch				

# M & W IGNITIONS

Performance & Quality since 1996

**CAUTION!  
HIGH VOLTAGE**

DISCONNECT POWER BEFORE  
WORKING ON UNIT

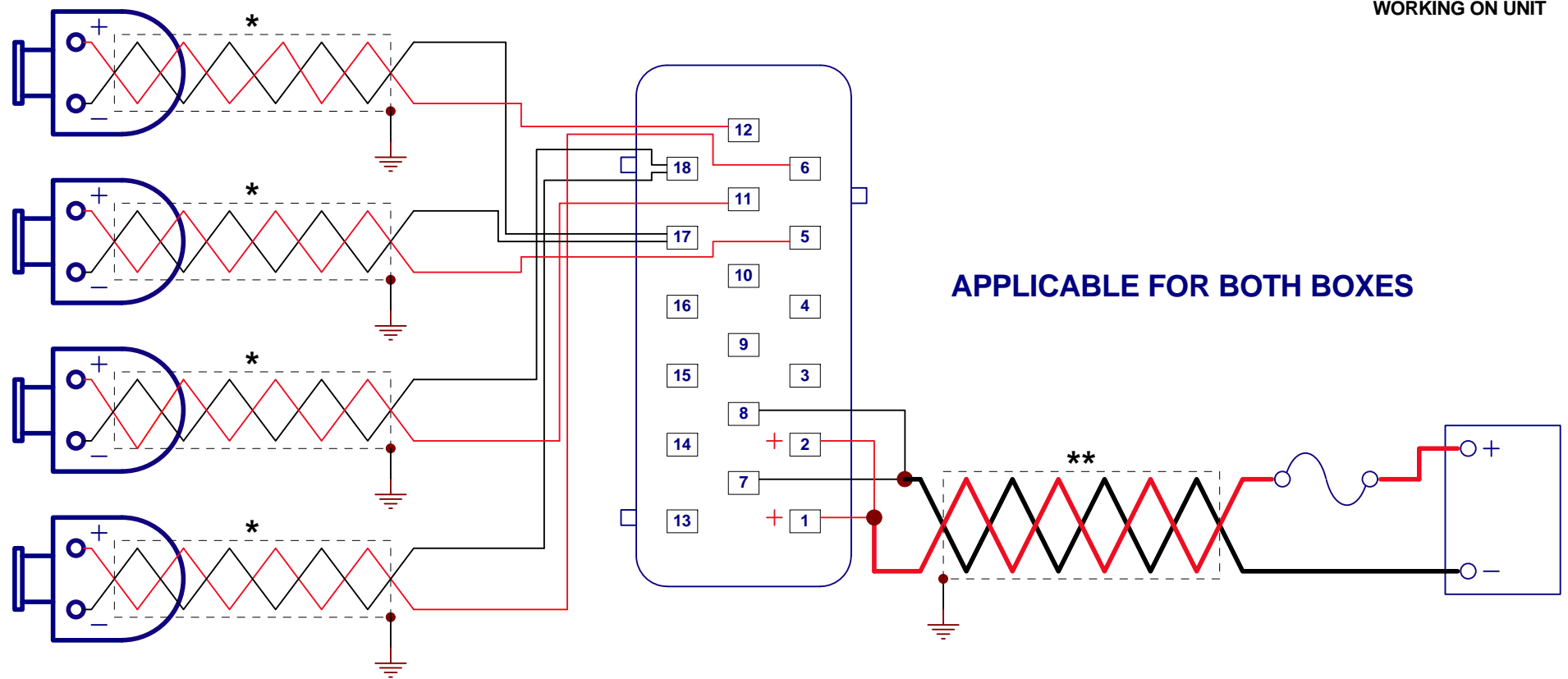

- \* Use twisted shielded cable grounded at one end only
- \*\* Shielded power cables required for Australian EMC compliance

Title			SHIELDING & EMC COMPLIANCE		
Size	Number	(C) M&W Ignitions		Revision	
A4				12.06.13.1	
Date:	19-Jun-2013	Sheet 1 of	1	Drawn By:	M&W
File:	D:\M&W\...\EMC.sch				