



PRO-14 Rotary

4 CHANNEL CAPACITOR DISCHARGE IGNITION

PLEASE REPORT ANY OMISSIONS OR
ERRORS TO SALES@MWIGNITIONS.COM

CONTENTS:

1. Installation notes
2. Ignition coil information
3. Mounting dimensions
4. Connections & Specifications
5. 4 Channel sequential ignition
6. 3 Channel waste spark ignition – 4 coil
7. 3 Channel waste spark ignition – 3 coil
8. 2 Channel waste spark ignition
9. Australian EMC requirements

CAUTION

**THIS WIRING DIAGRAM IS
APPLICABLE ONLY TO IGNITION
SYSTEMS WITH THE SERIAL
NUMBER PREFIX STARTING**

41xxxx

**USE OF INCORRECT DIAGRAM
WILL VOID WARRANTY AND
MAY DAMAGE UNIT**

INSTALLATION NOTES

MOUNTING

Do not mount the unit where it will be exposed to water or other liquids and ensure the bottom drain slots are unobstructed. Select a location away from excessive heat and provide a cooling air supply if required. Use soft rubber (40 duro) mounts on all four corners to isolate from strong vibration.

IGNITION LEADS & SPARKPLUGS

Straight metal wire ignition leads radiate electrical interference which may cause erratic operation of nearby electronic devices including the CDI. Carbon suppressed ignition leads are not capable of conducting the CDI energy without becoming damaged.

For best performance use spiral wound inductively suppressed metal core ignition leads such as those produced by Magnecor®. Where possible use non resistor spark plugs to reduce energy loss.

WIRING & POWER SUPPLY

FAILURE TO INSTALL THE RECOMMENDED SIZE FUSE WILL VOID WARRANTY

Trigger input & coil output numbers indicate ignition sequence not cylinder number.

250mJ and larger Pro-Drag CDI systems must not be operated below 13V.

Voltage boosters may limit CDI operation and ignition performance will not increase when operated above 13.8V

Connect the CDI directly to the battery with the recommended gauge wire. All coil negative wires must be joined at or in the connector.

Use twisted pair wire for all power and coil connections. To comply with Australian EMC 'C Tick' standards and for ultimate noise suppression use shielded twisted pair wire.

TRIGGERING

(NOT APPLICABLE TO RELUCTOR TRIGGER IGNITIONS)

All M&W CDI systems are edge triggered and default to falling edge ignition, to select rising edge ignition connect the 'Trigger Edge' pin to the 'Signal Ground' pin. Dwell or duty cycle settings do not effect the CDI operation or performance.

Where the ecu contains an in built igniter or there is an igniter between the ECU and CDI it may be necessary to select rising edge ignition.

For Autronic® multiplex ignitions set the ecu for –VE Edge (Pulse).

THE TRIGGER EDGE ON THE CDI MUST BE SET THE SAME AS THAT IN THE ECU.

LED INDICATOR

After initially applying power to the CDI the LED will illuminate for 1 second to indicate normal operation then extinguish. The LED will then flash briefly with each consecutive trigger event received.

A repeated double flash of the LED indicates a possible faulty ignition coil, faulty wiring, low supply voltage or damage to the CDI.

TESTING

The CDI may be tested by momentarily grounding the inputs (with the exception of Reluctor trigger cdi's where the input must go below ground to trigger the unit), this will cause the corresponding ignition coil to spark. Do not conduct this test without a grounded sparkplug installed.

CAUTION

TO PREVENT IGNITION COIL DAMAGE DO NOT FIRE THE CDI WITHOUT A GROUNDED SPARK PLUG AND DO NOT MAKE THE SPARK JUMP AN EXCESSIVE GAP

CHECK IGNITION TIMING AFTER COMPLETION

IGNITION COILS

COP COILS

COP (coil on plug) coils with built in drivers are not suitable for use with CDI ignitions. Small COP ignition coils may overheat when used in direct fire cdi applications. Inductive COP coils must be wired reverse polarity.

COIL SELECTION

Most inductive ignition coils will work with CDI systems. For best performance they should have very low primary resistance and inductance and a turns ration between 75 and 100 to 1.

For ultimate CDI ignition power use a CDI specific ignition coil such as our CDI COP pencil coils or Ferrite CDI coils.

FERRITE CDI COILS

Be aware when buying ferrite CDI coils from other suppliers who do not have the knowledge or experience to correctly prepare them for automotive use. Due to their fragile nature and poor quality control during manufacture it is easy to experience premature ignition coil failure and engine misfiring unless correctly assembled. All coils prepared by M&W are individually tested before sale.

Note! Ferrite CDI coils are for direct fire ignition only. For high performance distributor applications use either the Crane[®] PS92 or MSD[®] HVC2 coils.

COIL POLARITY

For correct operation inductive ignition coils should be wired with their primary polarity reversed.

CAUTION!

DAMAGE TO IGNITION COILS MAY OCCUR IF OPERATED WITH AN EXCESSIVE SPARK GAP.

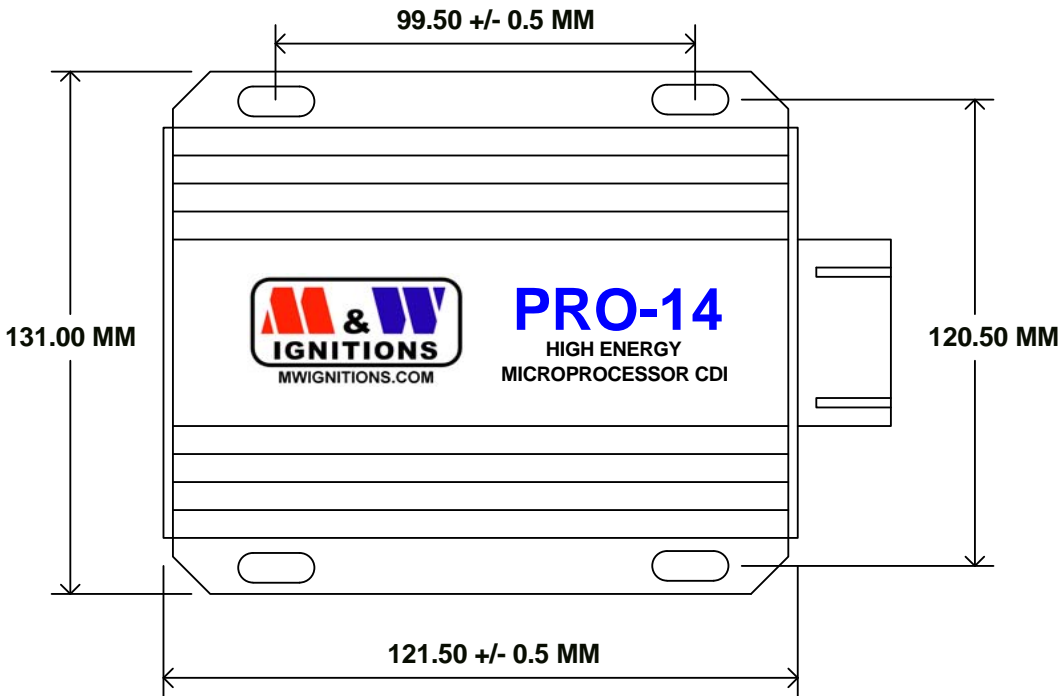

1.1

Slot dimensions - 5mm * 10mm

Title			MOUNTING DIMENSIONS		
Size	Number	Revision			
A4	SERIES 3				
Date:	9-Mar-2009	Sheet 1 of	1		
File:	E:\M&W\Rotary mounting dimensions.sc		Drawn By:	M&W	

M & W IGNITIONS

Performance & Quality since 1996

CAUTION!
HIGH VOLTAGE



DISCONNECT POWER BEFORE WORKING ON UNIT

VIEWED FROM BACK OF CONNECTOR



FAILURE TO INSTALL FUSE WILL VOID WARRANTY

TRIGGER EDGE SELECTION

Falling edge ignition - leave pin #9 disconnected.
Rising edge ignition - connect pin #9 to pin #10.

When triggering this unit of an existing ignition module or an ecu with built in igniters such as the Microtech 'MTX' series it may be necessary to select rising edge trigger.

SPECIFICATIONS

Supply voltage = 13.8V DC negative ground
Operating voltage = +6V to +18V (Restrictions apply)
Maximum supply current = 7.5A
Off current < 700uA
Maximum speed = 10,500 RPM
Coil primary voltage = 480V
Spark energy = 115 millijoules/plug
Trigger = 10mA open collector drive
Ignition split = 0 to infinity
Tacho = 12V, 25mA square wave
Maximum continuous operating temperature = 105°C

KEEP ALL INPUTS WELL SEPARATED FROM COIL OUTPUTS

1 +12V (Battery)	7 Ground (Battery)	13 Trigger D
2 +12V (Battery)	8 Ground (Battery)	14 Trigger B
3 Trigger C	9 Trigger edge	15 Trigger A
4 Tacho	10 Trigger edge	16 Ignition switch
5 Coil C +	11 Coil B +	17 Coils C & D -
6 Coil A +	12 Coil D +	18 Coils A & B -

Title			TWIN MICROPROCESSOR CDI		
Size	Number	Revision			
A4	SERIES 3	1.2			
Date:	9-Mar-2009	Sheet 1 of	1		
File:	E:\M&W\Rotary_S3_1.sch	Drawn By:	M&W		

M & W IGNITIONS

Performance & Quality since 1996

CAUTION!
HIGH VOLTAGE



DISCONNECT POWER BEFORE WORKING ON UNIT

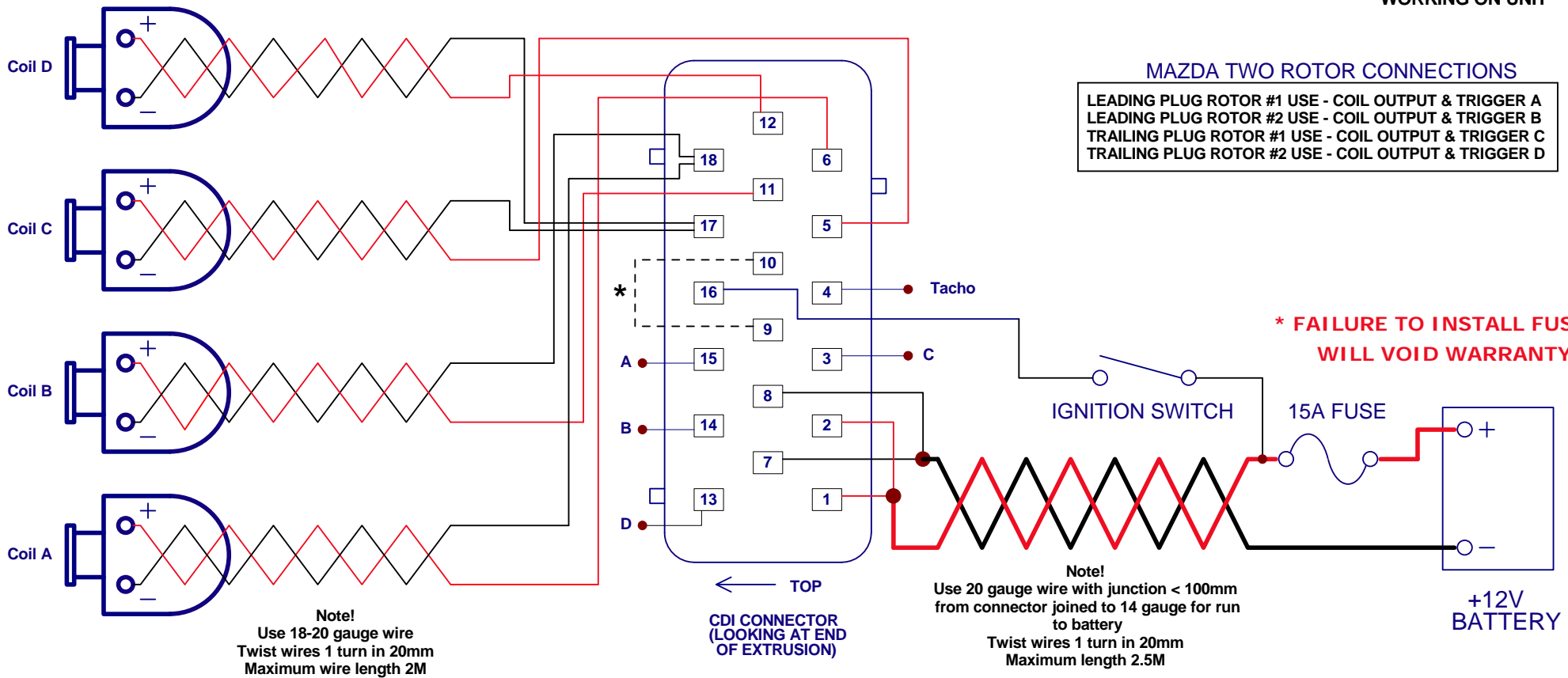

* See instructions for trigger edge selection link

Title				DIRECT FIRE ROTARY CDI	
Size	Number	Revision			
A4	SERIES 3	1.2			
Date:	9-Mar-2009	Sheet 1 of	1		
File:	E:\M&W\Rotary_S3_2.sch	Drawn By:	M&W		

M & W IGNITIONS

Performance & Quality since 1996

CAUTION!
HIGH VOLTAGE



DISCONNECT POWER BEFORE WORKING ON UNIT

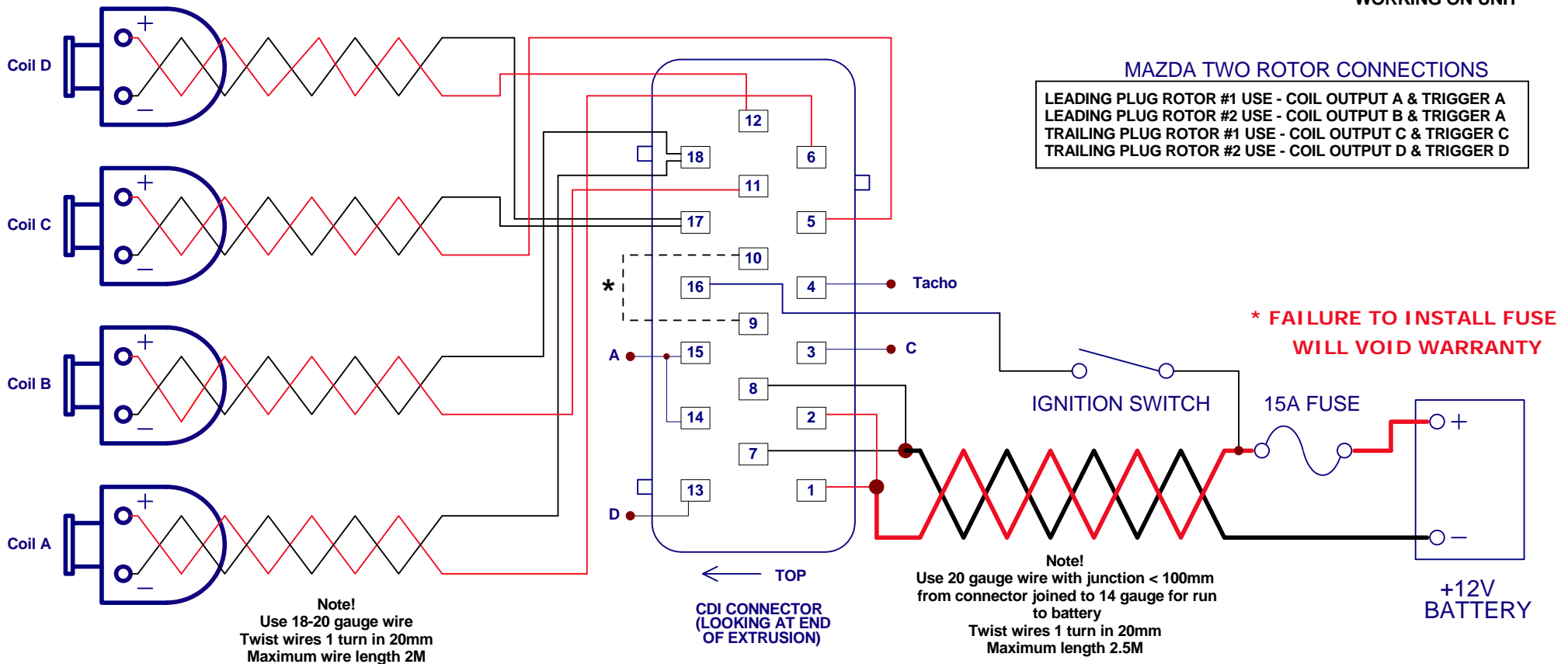

APPLICABLE FROM S/NO 410421

Title THREE TRIGGER ROTARY CDI (Version 1)			
Size A4	Number SERIES 3	Revision 1.2	
Date:	9-Mar-2009	Sheet 1 of	1
File:	E:\M&W\Rotary_S3_5.sch	Drawn By:	M&W

*** See instructions for trigger edge selection link**

M & W IGNITIONS

Performance & Quality since 1996

CAUTION!
HIGH VOLTAGE



DISCONNECT POWER BEFORE WORKING ON UNIT

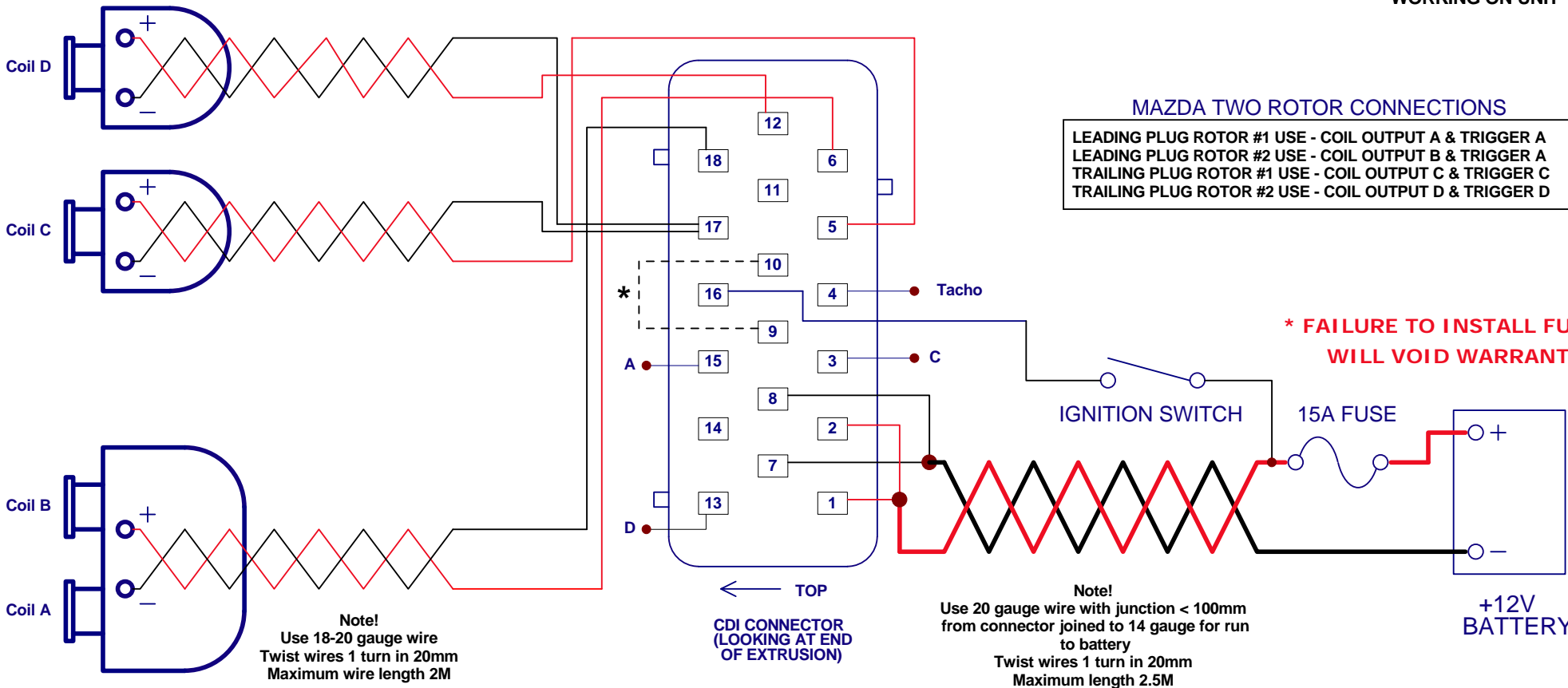

* See instructions for trigger edge selection link

Title THREE TRIGGER ROTARY CDI (Version 2)			
Size A4	Number SERIES 3	Revision 1.2	
Date:	9-Mar-2009	Sheet 1 of	1
File:	E:\M&W\Rotary_S3_3.sch	Drawn By:	M&W

M & W IGNITIONS

Performance & Quality since 1996

CAUTION!
HIGH VOLTAGE



DISCONNECT POWER BEFORE WORKING ON UNIT

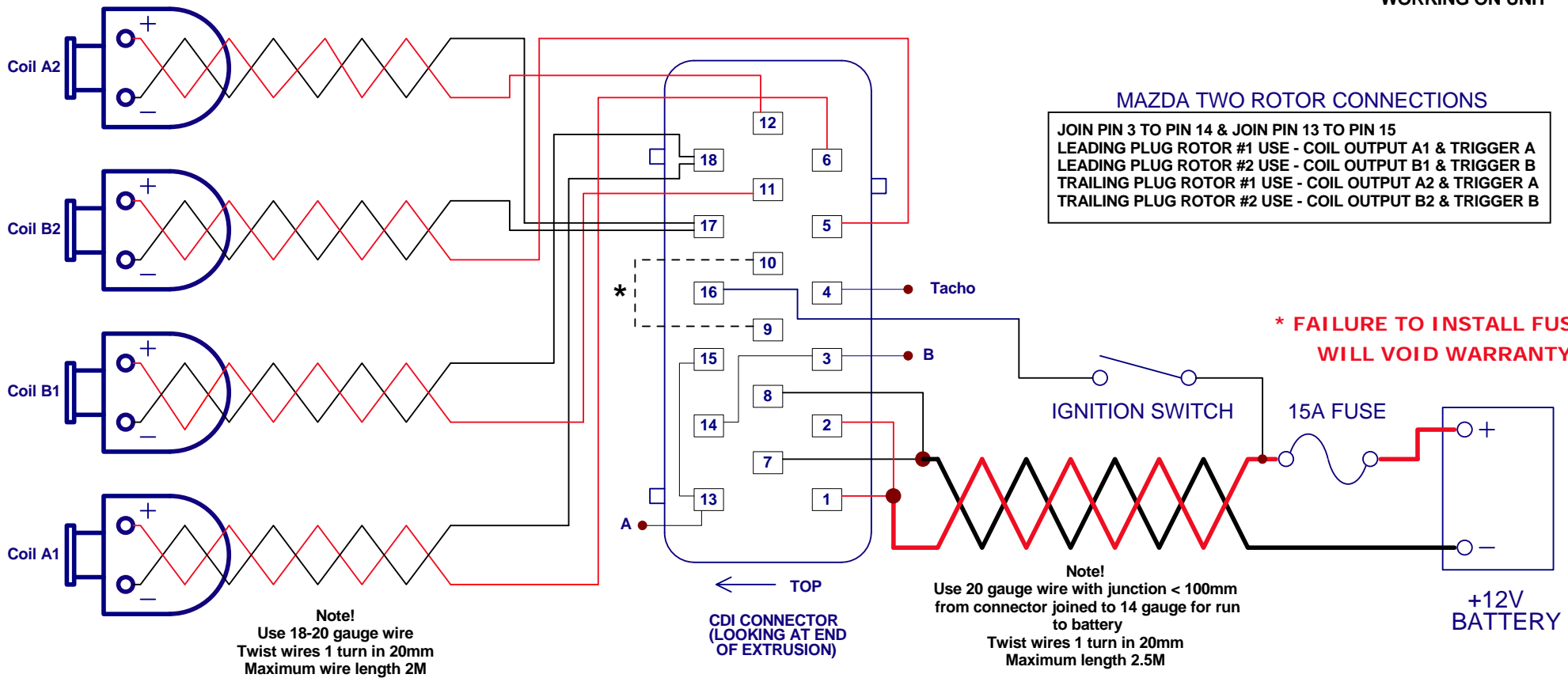

* See instructions for trigger edge selection link

Title			
TWO TRIGGER ROTARY CDI			
Size	Number	Revision	
A4	SERIES 3	1.2	
Date:	9-Mar-2009	Sheet 1 of 1	
File:	E:\M&W\Rotary_S3_4.sch	Drawn By:	M&W

M & W IGNITIONS

Performance & Quality since 1996

CAUTION!
HIGH VOLTAGE



**DISCONNECT POWER BEFORE
WORKING ON UNIT**

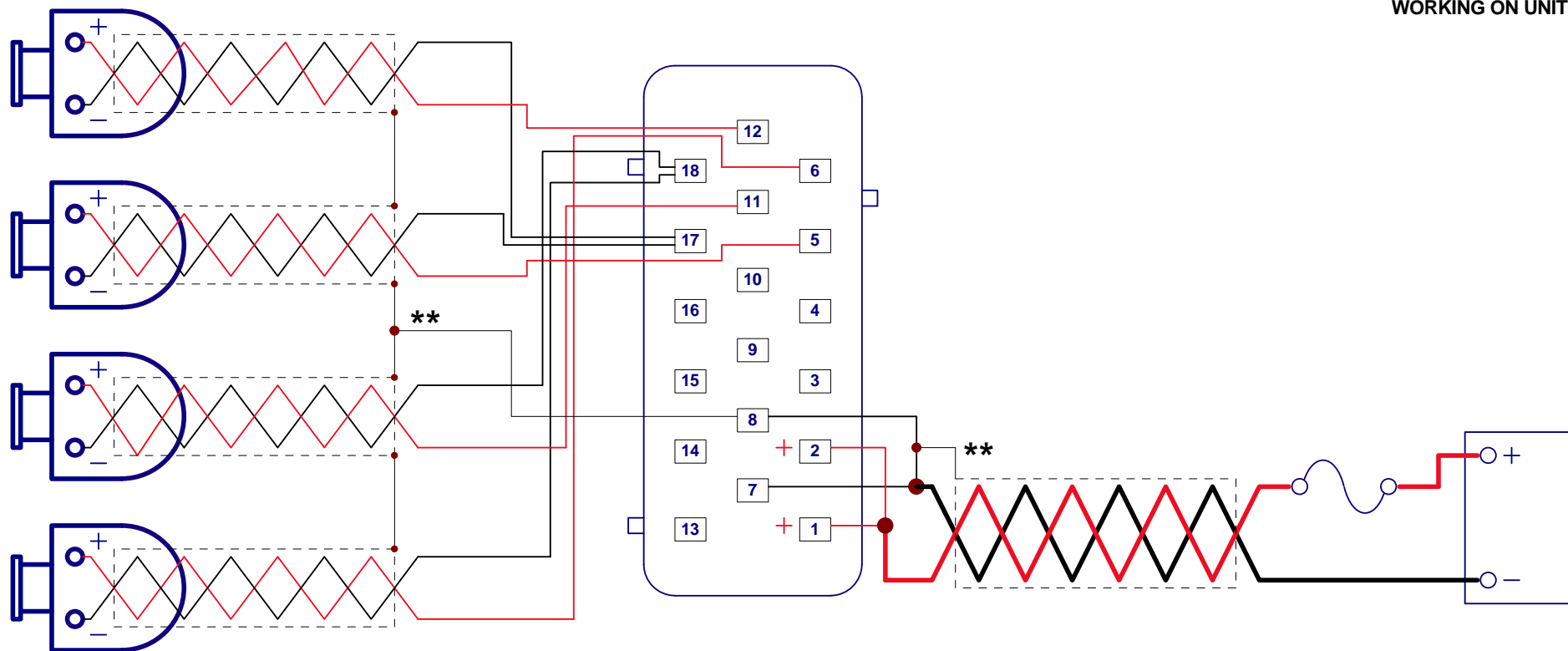

**** Shielded cables required for Australian EMC compliance**

Title			AUSTRALIAN EMC REQUIREMENTS		
Size	Number	Revision			
A4	PRO-14 S3	1.1			
Date:	9-Mar-2009	Sheet 1 of	1		
File:	E:\M&W\Diagrams\Pro-14 S3\EMC.sch	Drawn By:	M&W		