



Pro-16b S4

ELECTRICAL WIRING & OPERATING INSTRUCTIONS

Applicable
S/No's 90xxxx

**FAILURE TO FOLLOW INSTRUCTIONS
WILL VOID WARRANTY**

CONTENTS:

2. Installation notes
6. Connections and specifications
7. 6 coil direct fire ignition
8. Mounting dimensions

**ADDITIONAL RESOURCES & UP TO DATE
INSTRUCTIONS AVAILABLE FROM WEBSITE**

INSTALLATION NOTES

(Pro-Street Series 4 systems)

MOUNTING

Failure to use supplied rubber mounts will void warranty!

Mount the unit in a dry location ensuring the bottom condensation slots are unobstructed and oriented to permit gravity drain. Select a location away from intense heat and if necessary provide a source of cooling air.

IGNITION LEADS

Do not use unsuppressed metal or carbon core ignition leads!

Use inductively suppressed spiral wound metal core ignition leads such as those available from Magnecor www.magnecor.com.

SPARK PLUGS

When using resistor spark plugs it is imperative to check the internal resistance as part of regular maintenance!

Open circuit or high resistance may cause failure of spark plug wires, ignition coils and CDI system.

The use of non resistor spark plugs will greatly enhance ignition energy however some installations may require the use of resistor spark plugs to allow correct ECU operation.

The use surface discharge or semi surface discharge spark plugs are limited to naturally aspirated engines.

Keep spark plug gap ≤ 0.025 " (0.6mm) for blown motors to prevent coil and CDI damage!

INSULATION PRECAUTIONS

Ensure spark plug boots are a tight fit on the ceramic insulators!

Degrease spark plug ceramic, ignition coil, spark plug boots and installation tooling to prevent insulator contamination and breakdown.

Use of dielectric grease on spark plug ceramic and inside ignition coil and spark plug boots will significantly improve insulation properties and ease installation/removal.

POWER SUPPLY

**REVERSE POLARITY WILL CAUSE IRREPARABLE DAMAGE!
ALWAYS INSTALL EXTERNAL FUSE!**

Do not use voltage boosters or connect through a PDM.

When using a total loss electrical system install either a 16V or 18V battery to ensure adequate supply voltage and isolate when charging.

WIRING

Wire ignition system directly to battery!

If required power/ground wire length exceeds recommendations use paired battery cable (power/ground) to make up distance. Do not rely on vehicle chassis to provide ground path.

Use of twisted shielded wire (similar to M27500) is recommended for all power and coil connections.

M&W CDI systems will open circuit the external fuse under conditions of over voltage or reverse polarity. Faults such as loose battery terminals/wiring or defective alternator/regulator may also cause for this to occur.

Main connector pins are designed to be roll crimped. Squeeze crimping or soldering will cause distortion possibly resulting in misfiring or incorrect CDI operation.

Keep coil primary wires one continuous length and well separated from HT leads, coil HV towers and input wiring.

TRIGGERING

If CDI trigger edge and ECU ignition edge do not match timing will be erratic and vary with RPM!

CDI ignition channels may be triggered in any sequence.

For correct operation trigger voltage relative to CDI ground must rise above 3.2V and fall below 1.6V.

S4 Pro-Street systems default to falling edge ignition. To select rising edge ignition install a jumper wire between 'Trigger edge' and 'Edge ground' input pins.

Trigger input and coil output letters (or numbers) indicate cdi firing sequence, if applicable, not cylinder number

Where the ECU contains an inbuilt igniter it may be necessary to select rising edge ignition on the CDI.

POWER LEVEL SWITCH

Drag Race only use only – install a permanent link between inputs 31 & 17 for constant high power level.

Street & Drag use – activate by grounding input through either a 'Hobbs' style manifold pressure switch or a programmable output from the ECU when increased ignition energy is required.

TUNING

Always re tune both fuel and timing curves after installing CDI!

CDI systems are edge triggered and not affected by changes in dwell settings. If uncertain set ECU dwell to 0.5mS.

M&W CDI systems may reduce combustion delay requiring a reduction in ignition timing. The resulting changes in cylinder burn may also require alterations to fuel flow curves.

TACHO OUTPUT

The tacho output provides a 50% duty cycle square wave signal 1.2V below battery supply voltage. This will work with most aftermarket digital tacho's however earlier types and those designed for coil negative triggering may not read accurately.

LED INDICATOR

After applying power to switch wire both the red and green LED's will illuminate for approximately 1 second.

The green led will then extinguish and flash briefly with each trigger event received

The red led will stay on to indicate high power mode or extinguish for low power mode.

A repeated double flash may indicate a faulty ignition coil, faulty wiring, low supply voltage or damage to the CDI.

TESTING

Do not conduct this test without grounded spark plugs installed!

The CDI may be tested by momentarily grounding the trigger inputs. This will cause the green LED to momentarily flash and corresponding ignition coil to spark.

COIL SELECTION

Do not use 'Prufex' brand outboard motor coils or AEM pencil coils under any circumstances!

For ultimate performance use only high quality known brand ignition coils specifically designed for CDI use such as the M&W #COI006.

Use COP coils at your own risk as coil failure/breakdown may damage CDI system.

Use of resistor spark plugs with COP coils is mandatory and plug gap must be kept below 0.020" (0.5mm) to prevent coil and CDI damage!

Ferrite core cdi coils are not recommended due to their short arc duration and high levels of EMI.

M & W IGNITIONS

Performance & Quality

CAUTION!
HIGH VOLTAGE



**DISCONNECT POWER BEFORE
WORKING ON UNIT**

VIEWED FROM BACK OF CONNECTOR



SPECIFICATIONS

Operating voltage	12.5V --> 18V DC
Polarity	Negative ground
Startup voltage	>= 6V
Maximum supply current	12A
Power off current	< 700uA
Maximum ignition frequency	1,400 Hz
Energy limit:	
115mJ	1,100 Hz
150mJ	850 Hz
Coil primary voltage:	
Low power	480V
High power	550V
Spark energy (per plug):	
Low power	115mJ
High power	150mJ
Trigger:	
Current	10mA
Edge	Adjustable
Voltage rising	>= 3.2V
Voltage falling	<= 1.6V
Tacho output:	
Voltage	Supply - 1.2V
Output current	100mA
Shape	Square wave
Operating temperature	<= 105°C
Dimensions	173L * 137W * 50H
Weight	1,030gm

1 +12V (Battery)	13 Ground (Battery)	25 Trigger C
2 +12V (Battery)	14 Ground (Battery)	26 Ignition switch
3 +12V (Battery)	15 Ground (Battery)	27
4 Trigger F	16 Trigger B	28
5 Trigger edge	17 Edge ground	29 Trigger D
6 Tacho (T)	18 Trigger A	30 Trigger E
7	19	31 Power (P)
8	20	32
9	21	33
10 Coil E +	22 Coil E & F -	34 Coil F +
11 Coil C +	23 Coil C & D -	35 Coil D +
12 Coil A +	24 Coil A & B -	36 Coil B +

Title			PRO-16b 115/150mJ SERIES 4		
Size	Number	(C) M&W Ignitions		Revision	28.11.16.1
A4					
Date:	28-Nov-2016			Sheet 1 of 1	
File:	D:\M&W\...\Pro-16b S4 1.sch			Drawn By:	WAG

Wire Specifications

POWER SUPPLY:

Use 12ga shielded wire from battery trifurcated into 18ga wire <= 100mm from connector. Junction is best achieved using a butt splice or barrel crimp. Maximum recommended wire length is 2M

IGNITION COILS:

Use 20ga shielded wire from cdi to coils and keep as one continuous length. Maximum recommended wire length is 2M

Read installation guide for important wiring details!

M & W IGNITIONS

Performance & Quality

**CAUTION!
HIGH VOLTAGE**

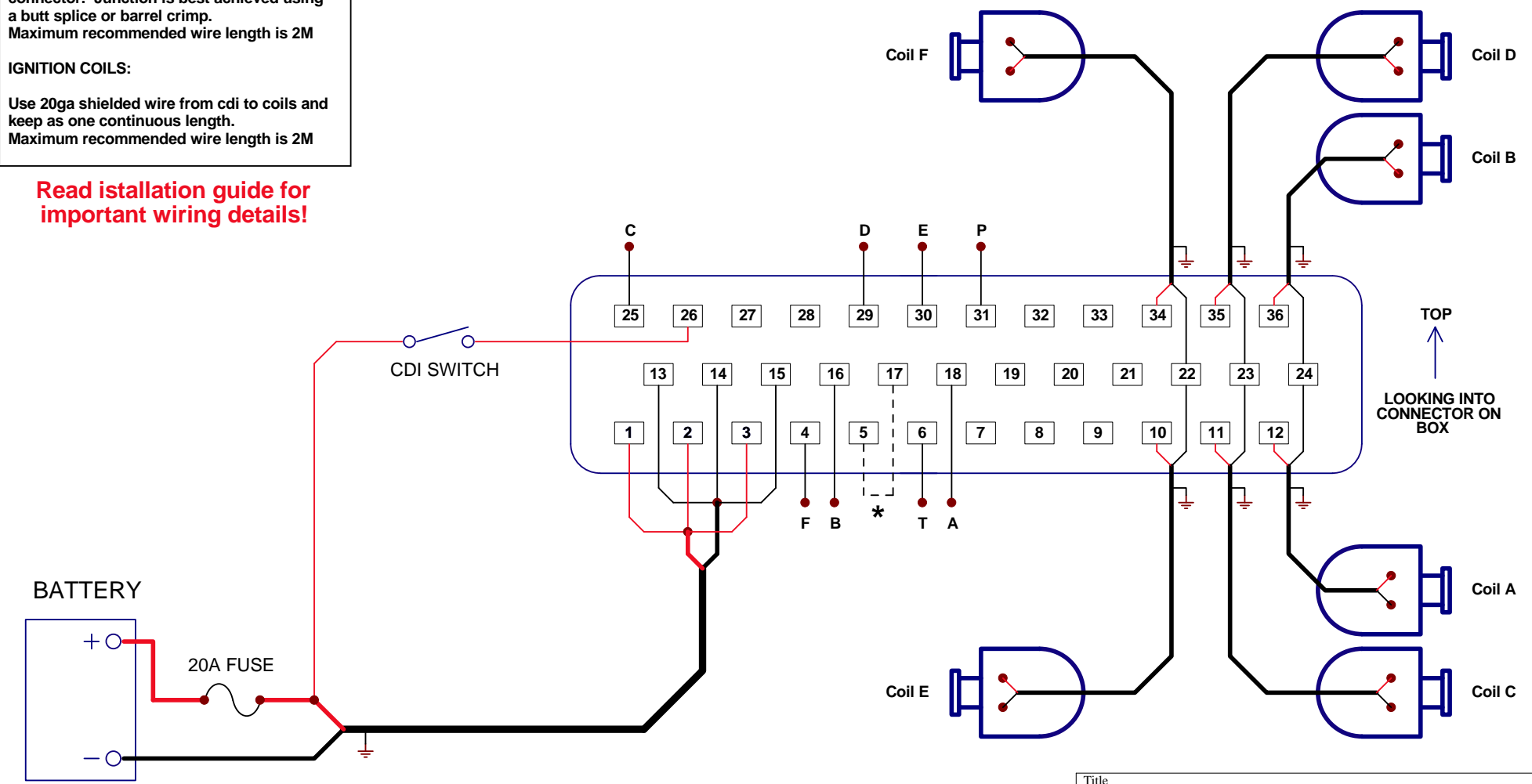

TOP
↑
LOOKING INTO CONNECTOR ON BOX

Reverse polarity connection without fuse installed will damage unit!

* See installation instructions

Title			6 CYLINDER DIRECT FIRE WIRING		
Size	Number	Revision			
A4	(C) M&W Ignitions	15.11.16.1			
Date:	28-Nov-2016	Sheet 1 of	1		
File:	D:\M&W\...\Pro-16b S4 2.sch	Drawn By:	WAG		

CAUTION!
HIGH VOLTAGE



**DISCONNECT POWER BEFORE
WORKING ON UNIT**

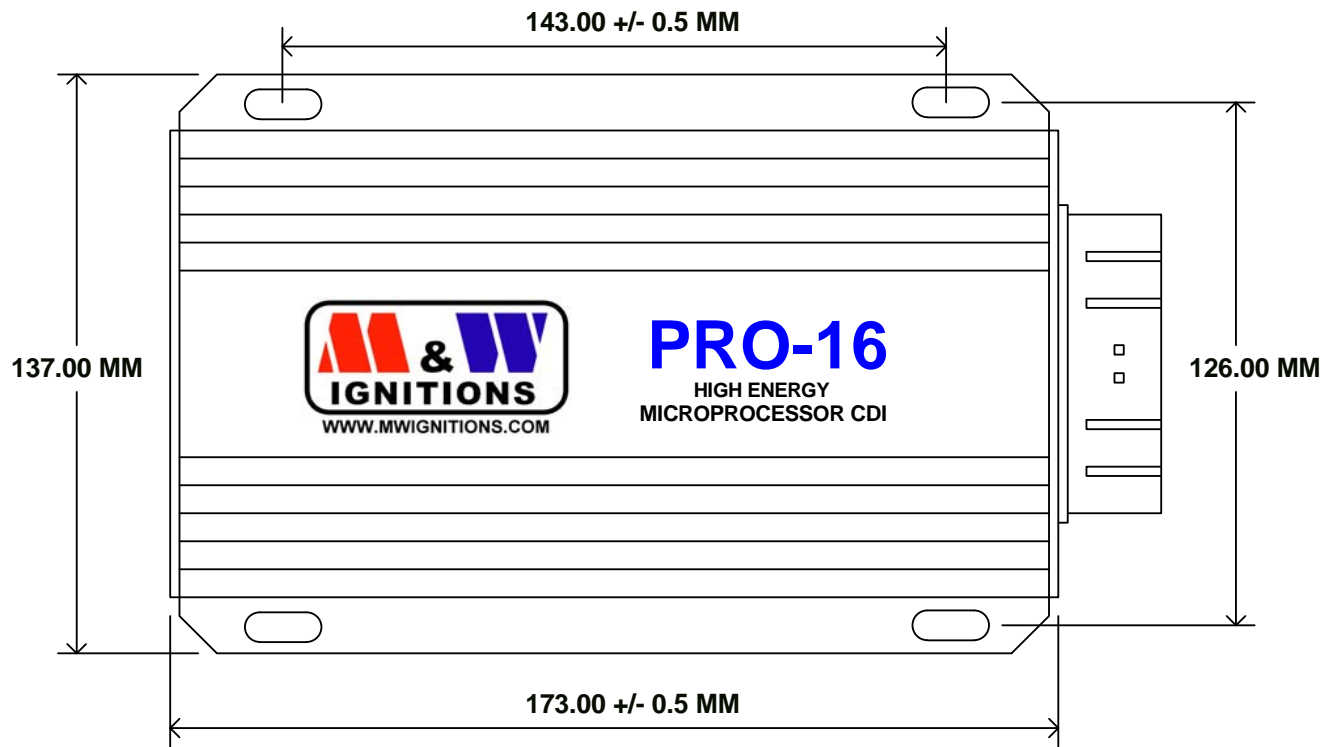

PRO-16
HIGH ENERGY
MICROPROCESSOR CDI

Slot dimensions - 5mm * 10mm

Title			PRO-16b 115/150mJ SERIES 4		
Size	Number	(C) M&W Ignitions		Revision	
A4				15.11.16.1	
Date:	15-Nov-2016	Sheet 1 of	1		
File:	D:\M&W\...\Pro-16b S4 dimensions.sch	Drawn By:	WAG		