



Pro-14R

2 Rotor 115mJ
Series 3

Applicable
S/No's 41xxxx

CONTENTS:

2. Installation notes
6. Ignition coil information
7. Connections & Specifications
8. Direct fire rotary ignition
9. Direct fire reciprocating ignition
10. Dimensions

**ADDITIONAL INSTALLATION RESOURCES & UP TO DATE
INSTRUCTIONS AVAILABLE FROM WEBSITE**

INSTALLATION NOTES

(Pro series street systems only)

MOUNTING

Do not mount the unit where it will be exposed to liquids, ensure the bottom condensation slots are unobstructed and oriented to permit gravity drain. Select a location away from intense heat and if necessary provide a source of cooling air.

Failure to use supplied rubber mounts will void warranty!

IGNITION LEADS

Do not use unsuppressed metal or carbon core ignition leads!

Use inductively suppressed spiral wound metal conductor ignition leads such as those made by Magnecor www.magnecor.com.

SPARK PLUGS

Non resistor spark plugs will greatly enhance ignition performance however some installations will require the use of resistor spark plugs to eliminate electrical interference.

When using resistor plugs measure their resistance as part of regular maintenance. Open circuit or high resistance may cause damage to spark plug wires, ignition coils and CDI.

Fixed gap surface discharge and semi surface discharge spark plugs are only suitable for naturally aspirated applications!

INSULATION PRECAUTIONS

Degrease spark plug ceramic, coil/plug boots and installation tooling to prevent insulation breakdown.

Use of dielectric grease on spark plug ceramic and inside coil/plug boots will significantly increase insulation properties and ease installation/removal.

POWER SUPPLY

Do not use voltage boosters or connect through a PDM.

If wired to a power source shared with the ECU or its sensors erratic operation may be experienced!

When running a total loss electrical system install either a 16V or 18V battery to ensure adequate supply voltage.

WIRING

Wire ignition system directly to battery!

If required wire length exceeds recommendations use paired battery cable (power and ground) to make up distance. Do not rely on vehicle chassis to provide ground path.

Use twisted pair wire for all power and coil connections. For improved noise suppression and/or to comply with EMC requirements use twisted shielded wire similar to M27500 series.

M&W CDI systems will open circuit the external fuse under conditions of over voltage or reverse polarity. Faults such as loose battery terminals/wiring or defective alternator/regulator may also cause this to occur.

Main connector pins are designed to be roll crimped. Squeeze crimping or soldering will cause distortion possibly resulting in misfiring or incorrect CDI operation. Use of dielectric grease in main connector may reduce water ingress.

Common coil negative wires must be joined at or in the cdi connector.

Keep coil primary wires well separated from HT leads, coil HV outlet, coil body and any input wiring!

TRIGGERING

For correct operation trigger voltage relative to CDI ground must rise above 3.2V and fall below 1.6V (except for Mitsubishi EVO trigger mods and single wire multiplex triggering).

M&W Pro street CDI systems default to falling edge ignition. To select rising edge ignition install a jumper wire between 'Trigger edge' and 'Edge ground' input pins.

Where possible trigger CDI directly from ECU!

If the ECU contains an in built igniter or it is not possible to remove the existing igniter then the CDI may be triggered off the igniter coil negative terminal.

If an igniter is installed in series with the trigger it will be necessary to change the ECU trigger edge or select rising edge ignition on the CDI.

If CDI trigger edge and ECU ignition edge do not match ignition timing will be erratic and vary with rpm!

Trigger input & coil output letters (or numbers) indicate CDI firing sequence not cylinder number unless otherwise stated.

POWER LEVEL SWITCH

Some M&W Pro street systems are provided with a (active low) power level switch. Do not manually activate this feature or operate continuously as this will significantly increase spark plug wear and system current draw. Activate by grounding input through either a 'Hobbs' style manifold pressure switch or programmable output from the ECU when elevated energy levels are required.

TWO SPARK SWITCH

Some M&W Pro street systems are provided with a two spark switch. Do not manually activate this feature as it will significantly increase spark plug wear and double system current draw. Activate by grounding the input through a programmable ECU output.

Hi power and Two spark can not be used simultaneously!

TUNING

CDI systems are 'edge triggered' and not effected by changes in dwell settings.

M&W CDI systems may reduce combustion delay requiring a reduction in ignition timing. The resulting changes in combustion

characteristics may also require alterations to fuel flow. Set ECU ignition delay to zero and tune engine as required.

Always re tune both fuel and timing curves after installing CDI ignition!

TACHO OUTPUT

The tacho output provides a 50% duty cycle square wave signal 1.2V below battery supply voltage. This will work with most aftermarket digital tacho's however earlier types and those designed for coil negative triggering may not read accurately.

LED INDICATOR

After applying power to input switch wire the LED will illuminate for approximately 1 second then extinguish. It will then flash briefly with each consecutive trigger event received. A repeated double flash of the LED may indicate a possible faulty ignition coil, faulty wiring, low supply voltage or damage to the CDI.

TESTING

The CDI may be tested by momentarily grounding the trigger inputs which will cause the LED to flash and corresponding ignition coil to spark.

Do not conduct this test without grounded spark plugs installed!

INSTALLATION PRECAUTIONS

The main cause of ignition damage is a high voltage flashover to ignition system wiring!

The fast rise time of CDI ignition output voltage increases the propensity for insulation breakdown in high voltage components therefore greater care must be taken with regards to cleanliness and wiring detail to prevent this occurring.

**UPDATED INSTRUCTIONS AND ADDITIONAL
INSTALLATION INFORMATION MAY BE FOUND ON OUR
WEBSITE**

IGNITION COILS

(Pro-Street systems only)

COIL SELECTION

Most inductive ignition coils will work reasonably well with CDI systems however for ultimate ignition energy use a coil specifically designed for CDI use such as the M&W #COI006(A/T). Coils with in built drivers are not suitable for use with CDI ignition.

COP COILS

Some COP (coil on plug) coils designed for inductive ignition may contain a HV blocking diode in the secondary winding, see coil polarity notes below.

Use resistive spark plugs with all COP coils. Keep plug gap < 0.020" (0.5mm) to prevent coil damage. DO NOT use AEM pencil coils under any circumstances!

FERRITE CDI COILS

Ferrite core cdi coils provide high secondary current however they may not be suitable for all applications due to their extremely short arc duration. The high level of EMI emitted by these coils may also require additional shielding to prevent electrical interference

**Do not use ferrite coils wired in parallel pairs!
Do not use 'Prufex' brand ferrite coils!**

COIL POLARITY

All diagrams are shown for cdi style coils. For correct operation with inductive ignition coils wire the primary connections in reverse to maintain correct spark plug polarity.

CAUTION!

**IGNITION DAMAGE MAY OCCUR IF OPERATED
WITH AN EXCESSIVE SPARK GAP**

M & W IGNITIONS

Performance & Quality

CAUTION!
HIGH VOLTAGE



DISCONNECT POWER BEFORE
WORKING ON UNIT

VIEWED FROM BACK OF CONNECTOR



SPECIFICATIONS

Operating voltage	12.5V -> 18V DC
Polarity	Negative ground
Startup voltage	>= 6V
Maximum supply current	7.0A
Power off current	< 700uA
Maximum ignition frequency	12,000 rpm
Energy limit:	
Four trigger mode	10,500 rpm
Coil primary voltage:	
Standard power	460V
Spark energy:	
Standard power	115mJ
Trigger:	
Current	10mA
Edge	Adjustable
Voltage rsing	>= 3.2V
Voltage falling	<= 1.6V
Tacho output:	
Voltage	Supply - 1.2V
Output current	100mA
Shape	Square wave
Operating temperature	<= 105°C
Dimensions	150L * 110W * 40H
Weight	870gm

1 +12V (Battery)	7 Ground (Battery)	13 Trigger T2
2 +12V (Battery)	8 Ground (Battery)	14 Trigger L2
3 Trigger T1	9 Trigger edge	15 Trigger L1
4 Tacho (T)	10 Edge ground	16 Ignition switch
5 Coil T1 +	11 Coil L2 +	17 Coil L1 & L2 -
6 Coil L1 +	12 Coil T1 +	18 Coil T1 & T2 -

Note! Trigger & coil locations may vary depending on schematic used.

Title TWO ROTOR DIRECT FIRE CDI		
Size A4	Number (C) M&W Ignitions	Revision 05.06.17.1
Date: 5-Jun-2017	Sheet of	Drawn By: M&W
File: D:\M&W\Rotary S3 I.sch		

Wire Specifications

POWER SUPPLY:

Use 14ga wire from battery bifurcated into 20ga wire <= 100mm from connector. Junction is best achieved using a Solistrand or similar butt splice / barrel crimp. Maximum recommended wire length is 2M

IGNITION COILS:

Use 20ga wire from cdi to coils and keep as one continuous length. Maximum recommended wire length is 2M

Read installation guide for important wiring details!

M & W IGNITIONS

Performance & Quality

**CAUTION!
HIGH VOLTAGE**



**DISCONNECT POWER BEFORE
WORKING ON UNIT**

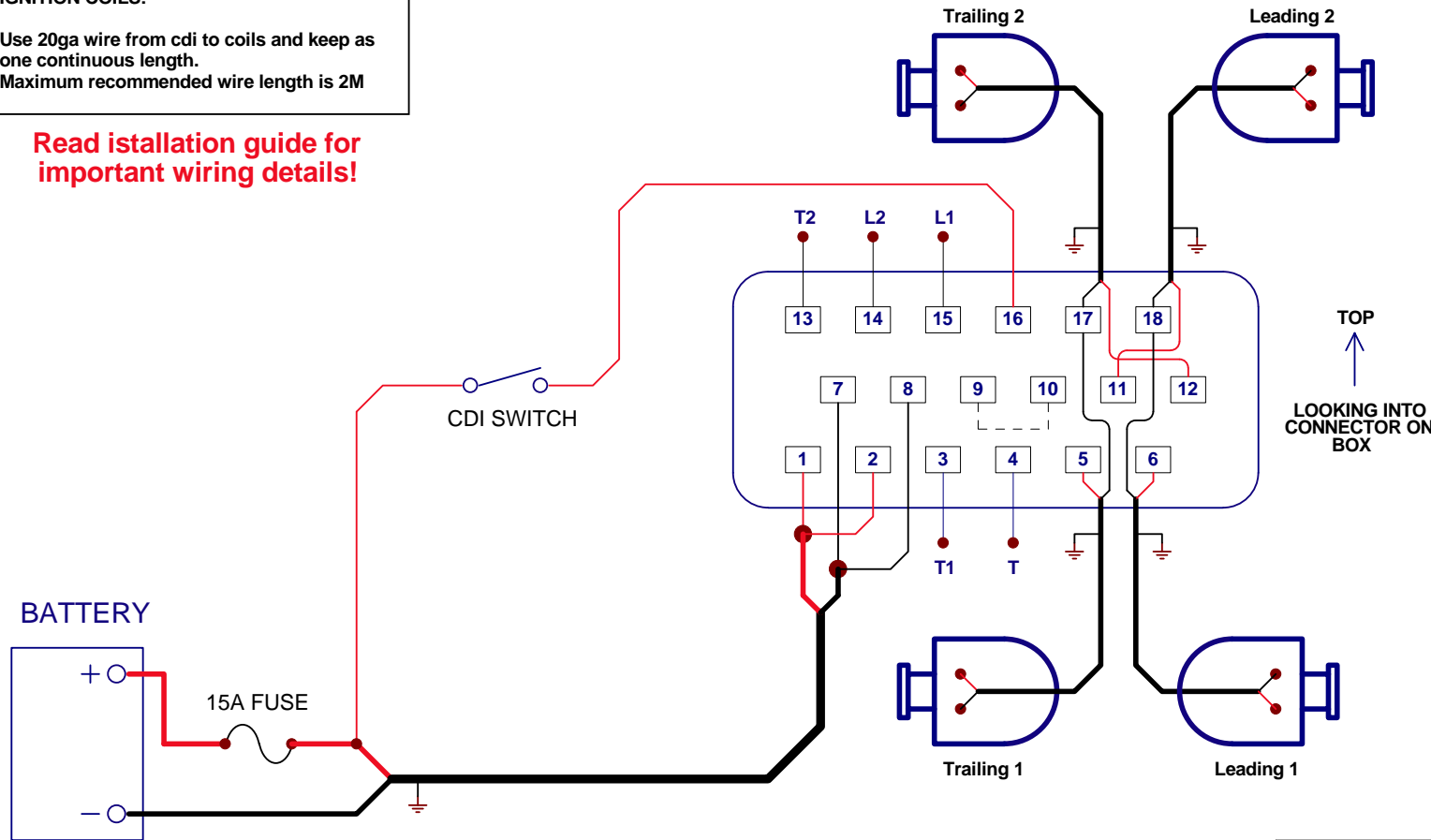

Title			FOUR COIL DIRECT FIRE
Size	Number	Revision	
A4	(C) M&W Ignitions	10.07.17.1	
Date:	10-Jul-2017	Sheet	1 of 1
File:	D:\M&W\...\Rotary S3 2.sch	Drawn By:	WAG

Wire Specifications

POWER SUPPLY:

Use 14ga wire from battery bifurcated into 20ga wire <= 100mm from connector. Junction is best achieved using a Solistrand or similar butt splice / barrel crimp. Maximum recommended wire length is 2M

IGNITION COILS:

Use 20ga wire from cdi to coils and keep as one continuous length. Maximum recommended wire length is 2M

Read installation guide for important wiring details!

M & W IGNITIONS

Performance & Quality

**CAUTION!
HIGH VOLTAGE**



**DISCONNECT POWER BEFORE
WORKING ON UNIT**

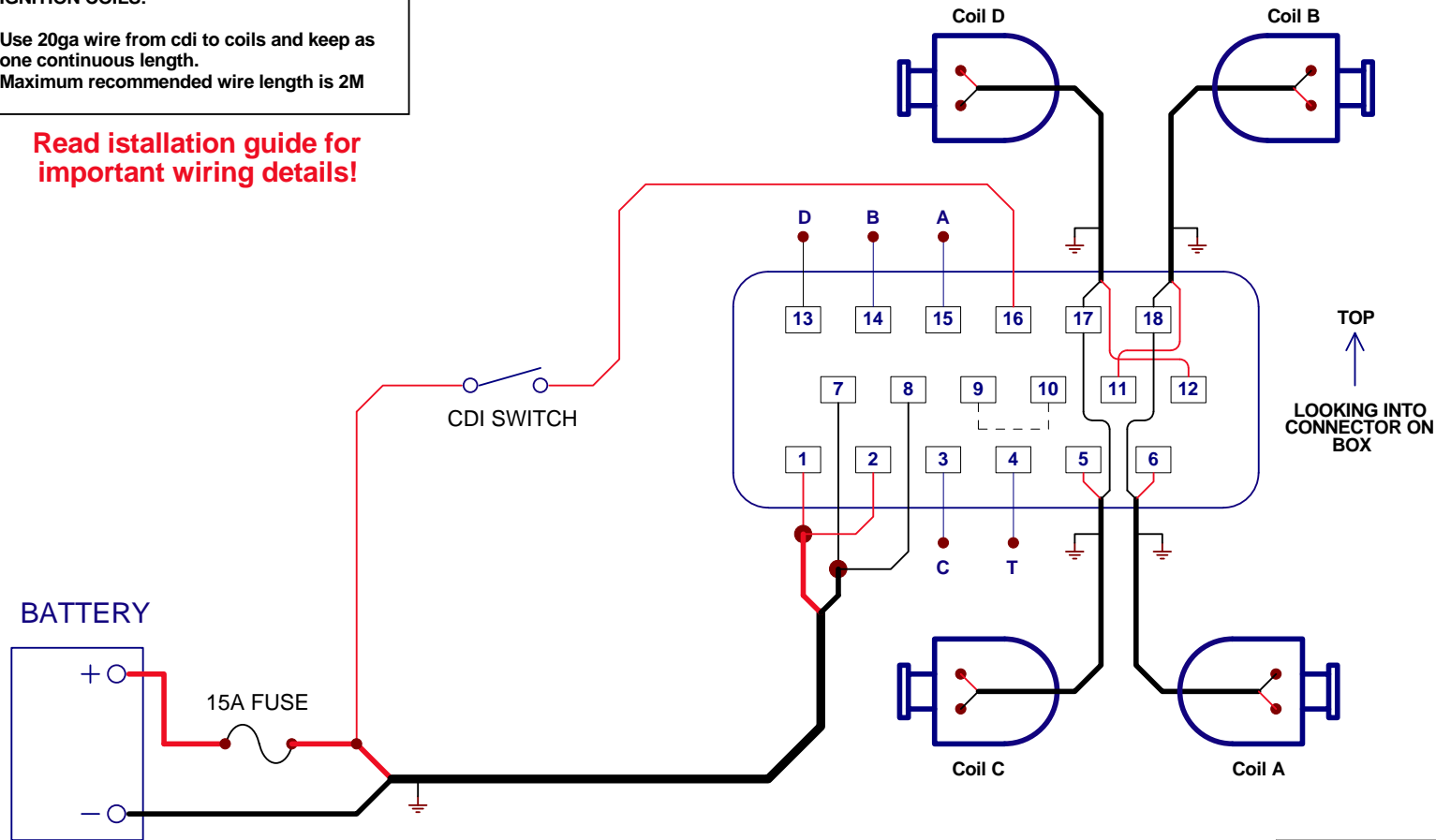

Title			RECIPROCATING DIRECT FIRE
Size	Number	Revision	
A4	(C) M&W Ignitions	10.07.17.1	
Date:	10-Jul-2017	Sheet 1 of 1	
File:	D:\M&W\...\Rotary S3 6.sch	Drawn By:	WAG



DISCONNECT POWER BEFORE WORKING ON UNIT

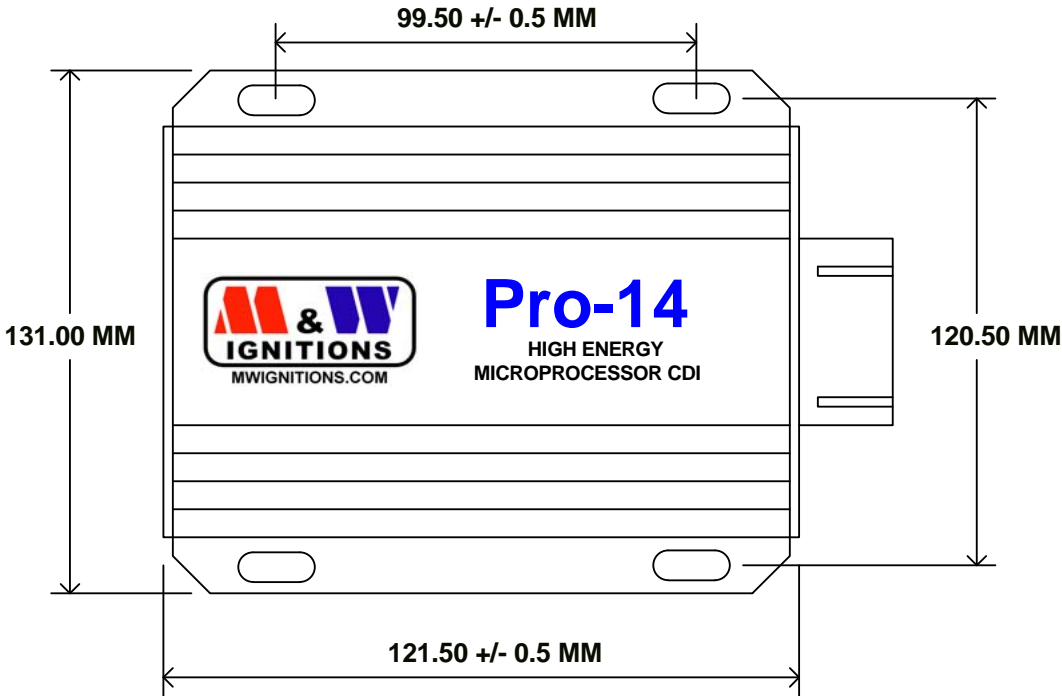

Pro-14
HIGH ENERGY
MICROPROCESSOR CDI

Slot dimensions - 5mm * 10mm

Title		PRO-14R ROTARY CDI	
Size	Number	Revision	
A4	(C) M&W Ignitions	12.05.17.1	
Date:	12-May-2017	Sheet 1 of 1	
File:	D:\M&W\...\Mounting dimensions.sch	Drawn By:	WAG